

TM 5-2350-262-10*

OPERATOR'S MANUAL

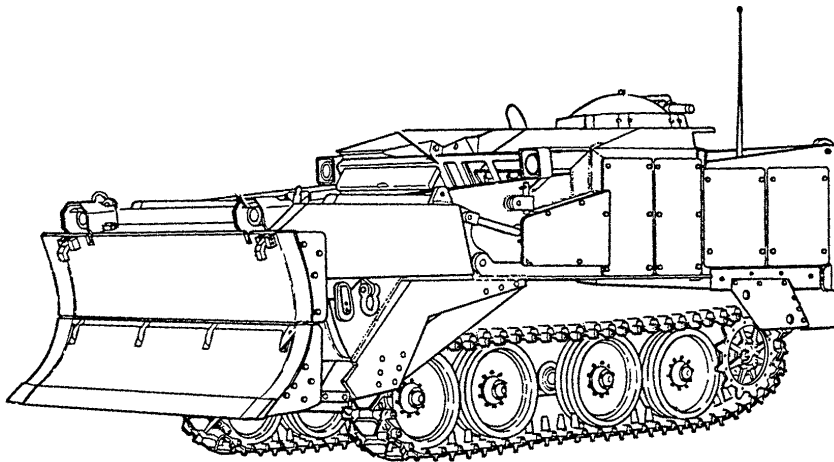

ARMORED COMBAT EARTHMOVER [ACE], M9 [2350-00-808-7100]

*This publication supersedes TM 5-2350-262-10
dated 31 October 1990

Approved for public release; distribution is unlimited.

HEADQUARTERS, DEPARTMENT OF THE ARMY

TABLE OF CONTENTS	i
-------------------	---

EQUIPMENT DESCRIPTION	1-3
-----------------------	-----

OPERATING INSTRUCTIONS	2-1
------------------------	-----

PREVENTIVE MAINTENANCE CHECKS AND SERVICES	2-9
--	-----

LUBRICATION INSTRUCTIONS	3-1
--------------------------	-----

TROUBLE-SHOOTING PROCEDURES	3-2
-----------------------------	-----

MAINTENANCE PROCEDURES	3-13
------------------------	------

MAINTENANCE OF AUXILIARY EQUIPMENT	3-29
------------------------------------	------

INDEX	INDEX 1
-------	---------

JUNE 1992

Change 5

**CHANGE
NO. 5**

**C-5
HEADQUARTERS
DEPARTMENT OF THE ARMY
WASHINGTON, D.C., 27 March 2000**

**OPERATOR'S MANUAL
ARMORED COMBAT EARTHMOVER
(ACE), M9
(NSN 2350-00-808-7100)**

TM 5-2350-262-10, dated June 1992, with change 1, 29 September 1993, change 2, 15 May 1996, change 3, 16 November 1998, and change 4, 30 June 1999, is changed as follows:

1. Remove old pages and insert new pages as indicated below.
2. New or changed material is indicated by a vertical bar in the margin.
3. Added or revised illustrations are indicated by a vertical bar adjacent to the illustration.

Remove pages

Cover
Change 4 List of Effective Pages
1-3 through 1-12 (Blank)
2-1 through 2-4
2-11 and 2-12
2-15 and 2-16
2-23 through 2-30
2-30.7 through 2-32
2-35 through 2-38
2-43 and 2-44
2-47 through 2-50
2-53 through 2-62
2-67 through 2-76
2-79 through 2-82
2-91 through 2-92
2-101 through 2-112

Insert pages

Cover
Change 5 List of Effective Pages
1-3 through 1-12 (Blank)
2-1 through 2-4
2-11 and 2-12
2-15 and 2-16
2-23 through 2-30
2-30.7 through 2-32
2-35 through 2-38
2-43 and 2-44
2-47 through 2-50
2-53 through 2-62
2-67 through 2-76
2-79 through 2-82
2-91 through 2-92
2-101 through 2-112

Approved for public release; distribution is unlimited.

File this sheet in the front of the publication for reference purposes.

TM 5-2350-262-10
C-5

Remove pages

2-119 through 2-124 (Blank)
3-13 through 3-14
3-21 and 3-22
A-1 and A-2
B-3 and B-4
C-3 and C-4
F-11 and F-14
F-21 and F-22
F-25 and F-26
F-31 through F-36
Back Cover

Insert pages

2-119 through 2-124 (Blank)
3-13 and 3-14
3-21 and 3-22
A-1 and A-2
B-3 and B-4
C-3 and C-4
F-11 through F-14
F-21 and F-22
F-25 and F-26
F-31 through F-36
Back Cover

By Order of the Secretary of the Army:

ERIC K. SHINSEKI
General, United States Army
Chief of Staff

Official:

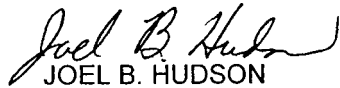
JOEL B. HUDSON

Administrative Assistant to the
Secretary of the Army

0001303

DISTRIBUTION: To be distributed in accordance with the Initial Distribution Number (IDN) 371271, requirements for TM 5-2350-262-10.

**CHANGE
NO. 4**

**C-4
HEADQUARTERS
DEPARTMENT OF THE ARMY
WASHINGTON, D.C., 30 June 1999**

**OPERATOR'S MANUAL
ARMORED COMBAT EARTHMOVER
(ACE), M9
(NSN 2350-00-808-7100)**

TM 5-2350-262-10, dated 26 June 1992, with change 1, 29 September 1993, change 2, 15 May 1996, and change 3, 16 November 1998, is changed as follows:

1. Remove old pages and insert new pages as indicated below.
2. New or changed material is indicated by a vertical bar in the margin.
3. Added or revised illustrations are indicated by a vertical bar adjacent to the illustration.

Remove pages

i and ii
1-7 and 1-8
2-3 through 2-6
2-8.1 and 2-8.2
2-27 through 2-30
2-93 and 2-94
3-25 through 3-28
B-11 and B-12
INDEX 1 through INDEX 4

Insert pages

List of Effective Pages

i and ii
1-7 and 1-8
2-3 through 2-6
2-8.1 and 2-8.2
2-27 through 2-30
2-93 and 2-94
3-25 through 3-28
B-11 and B-12
INDEX 1 through INDEX 4

TM 5-2350-262-10

By Order of the Secretary of the Army:

DENNIS J. REIMER
General, United States Army
Chief of Staff

Official:

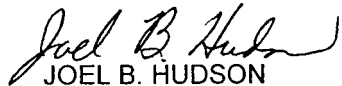
JOEL B. HUDSON
Administrative Assistant to the
Secretary of the Army
0001303

DISTRIBUTION: To be distributed in accordance with the Initial Distribution Number (IDN) TBD, requirements for TM 5-2350-262-10.

CHANGE
NO. 3

HEADQUARTERS
DEPARTMENT OF THE ARMY
Washington D.C., 16 November 1998

OPERATOR'S MANUAL
ARMORED COMBAT EARTHMOVER
(ACE), M9
(NSN 2350-00-808-7100)

TM 5-2350-262-10, 26 June 1992, is changed as follows:

1. Remove old pages and insert new pages as indicated below.
2. New or changed material is indicated by a vertical bar in the margin.
3. Added or revised illustrations are indicated by a vertical bar adjacent to the illustration.

Remove pages

a through d
i and ii
1-1 through 1-6
1-9 through 1-12
2-1 through 2-4
2-11 and 2-12
2-19 through 2-22
2-30.3 and 2-30.4
2-30.7 (2-31 deleted)
and 2-32
2-33 and 2-34
2-41 and 2-42
2-45 through 2-48
2-53 and 2-54
2-73 through
2-80.1 (2-80.2 blank)
2-93 through 2-100
2-103 through 2-112
2-119 and 2-120
3-1 and 3-2

Insert pages

a through d
i and ii
1-1 through 1-6
1-9 through 1-12
2-1 through 2-4
2-11 and 2-12
2-19 through 2-22
2-30.3 and 2-30.4
2-30.7 (2-31 deleted)
and 3-32
2-33 and 2-34
2-41 (2-42 deleted)
2-45 through 2-48
2-53 and 2-54
2-73 through 2-80
(2-80.1/2-80.2 blank) deleted
2-93 through 2-100
2-103 through 2-112
2-119 and 2-120
3-1 and 3-2

Approved for Public release; distribution is unlimited.

File this sheet in front of the publication for reference purposes.

TM 5-2350-262-10

C-3

Remove pages

3-5 through 3-10
3-13 and 3-14
3-25 through 3-28
3-31 through 3-36

A-1 and A-2
B-3 through B-8
B-11 through B-16
E-1 and E-2
None

Index 1 through Index 4
SAMPLE DA Form 2028-2
Blank DA Forms 2028-2

Insert pages

3-5 through 3-10
3-13 and 3-14
3-25 through 3-28
3-31 (3-32 blank)
(3-32 through 3-36 deleted)

A-1 and A-2
B-3 through B-8
B-11 through B-16
E-1 and E-2
F-1 through F-39
(F-40 blank)
Index 1 through Index 4
SAMPLE DA Form 2-28-2
Blank DA Forms 2-28-2

By Order of the Secretary of the Army:

DENNIS J. REIMER
General, United States Army
Chief of Staff

Official:

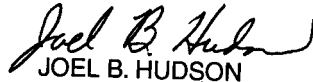
JOEL B. HUDSON

*Administrative Assistant to the
Secretary of the Army*

05369

DISTRIBUTION: To be distributed in accordance with the
Initial Distribution Number (IDN) 371271, requirements for
TM 5-2350-262-10.

C-2

CHANGE

HEADQUARTERS

DEPARTMENT OF THE ARMY

NO. 2

WASHINGTON, D.C., 15 May 1996

**OPERATOR'S MANUAL
ARMORED COMBAT EARTHMOVER
(ACE), M9
(NSN 2350-00-808-7100)**

TM 5-2350-262-10, dated 26 June 1992, is changed as follows:

1. Remove old pages and insert new pages as indicated below.
2. New or changed material is indicated by a vertical bar in the margin.
3. Added or revised illustrations are indicated by a vertical bar adjacent to the illustration.

Remove pages

a through d
i and ii
1-1 through 1-10
2-3 through 2-6
None
2-11 through 2-16
2-19 and 2-20
2-25 and 2-26
2-29 through 2-30.2
2-30.5 through 2-32

2-35 and 2-36
2-39 and 2-40
2-43 and 2-44
2-51 and 2-52
2-55 through 2-76
2-79 and 2-80
2-83 through 2-86

Insert pages

a through d
i and ii
1-1 through 1-10
2-3 through 2-6
2-8.1 (2-8.2 blank)
2-11 through 2-16
2-19 and 2-20
2-25 and 2-26
2-29 through 2-30.2
2-30.5 through 2-30.7
(2-31 deleted) and 2-32
2-35 and 2-36
2-39 and 2-40
2-43 and 2-44
2-51 and 2-52
2-55 through 2-76
2-79 and 2-80
2-83 through 2-86

Approved for Public release; distribution is unlimited.

File this sheet in front of the publication for reference purposes.

TM 5-2350-262-10
C-2

Remove pages

None

2-91 through 2-94
2-97 and 2-98
2-101 through 2-104
2-107 through 2-118
2-121 and 2-122
3-13 through 3-16
None
3-31 and 3-32
3-35 and 3-36
B-1 through B-18
C-1 through C-4
D-5 (D-6 blank)
E-1 and E-2
Index 1 through Index 4
SAMPLE DA Form 2-2028-2
Blank DA Forms 2-2028-2

Insert pages

2-86.1 through 2-86.3
(2-86.4 blank)
2-91 through 2-94
2-97 and 2-98
2-101 through 2-104
2-107 through 2-118
2-121 and 2-122
3-13 through 3-16
3-22.1 (3-22.2 blank)
3-31 and 3-32
3-35 and 3-36
B-1 through B-18
C-1 through C-4
D-5 (D-6 blank)
E-1 and E-2
Index 1 through Index 4
SAMPLE DA Form 2-2028-2
Blank DA Forms 2-2028-2

By Order of the Secretary of the Army:

Official:



JOEL B. HUDSON

*Administrative Assistant to the
Secretary of the Army*

01959

DENNIS J. REIMER
*General, United States Army
Chief of Staff*

DISTRIBUTION:

To be distributed in accordance with DA Form 12-37-E, block 1271, requirements for TM 5-2350-262-10.

**CHANGE
NO. 1**

**HEADQUARTERS
DEPARTMENT OF THE ARMY
Washington D.C., 29 September 1993**

**OPERATOR'S MANUAL
ARMORED COMBAT EARTHMOVER
(ACE), M9
(NSN 2350-00-808-7100)**

TM5-2350-262-10, 26 June 1992, is changed as follows:

1. Remove old pages and insert new pages as indicated below.
2. New or changed material is indicated by a vertical bar in the margin.
3. Added or revised illustrations are indicated by a vertical bar adjacent to the illustration.

Remove pages

c and d
1-3 through 1-10
2-9 through 2-32

2-35 and 2-36
2-51 and 2-52
2-55 through 2-70
2-73 through 2-78

2-91 through 2-94
2-97 and 2-98
2-101 and 2-102
2-105 and 2-106
2-109 through 2-118
2-121 and 2-122
3-3 and 3-4
3-7 and 3-8
3-13 through 3-24
3-27 and 3-28
3-31 through 3-36
B-7 and B-8
B-11 and B-12
D-1 and D-2
E-1 and E-2
Index 1 through Index 4

Insert pages

c and d
1-3 through 1-10
2-9 through 2-10.1 (2-10.2 blank) and
2-11 through 2-30 and 2-30.1
through 2-30.7 (2-31 deleted) and 2-32

2-35 and 2-36
2-51 and 2-52
2-55 through 2-70
2-73 through 2-78
2-80.1 (2-80.2 blank)
2-91 through 2-94
2-97 and 2-98
2-101 and 2-102
2-105 and 2-106
2-109 through 2-118
2-121 and 2-122
3-3 and 3-4
3-7 and 3-8
3-13 through 3-24
3-27 and 3-28
3-31 through 3-36
B-7 and B-8
B-11 and B-12
D-1 and D-2
E-1 and E-2
Index 1 through Index 4

File this sheet in front of the publication for reference purposes.

Approved for public release; distribution is unlimited.

By Order of the Secretary of Army

GORDON R. SULLIVAN
General, United States Army
Chief of Staff

Official:

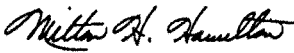
MILTON H. HAMILTON
Administrative Assistant to the
Secretary of the Army

05198

Distribution:

To be distributed in accordance with DA Form 12-37-E, Block 1271, requirements for
TM5-2350-262-10.

WARNING

CARBON MONOXIDE POISONING CAN BE DEADLY

CARBON MONOXIDE IS A COLORLESS, ODORLESS, DEADLY, POISONOUS GAS WHICH, WHEN BREATHED, DEPRIVES THE BODY OF OXYGEN AND CAUSES SUFFOCATION. EXPOSURE TO AIR CONTAMINATED WITH CARBON MONOXIDE PRODUCES SYMPTOMS OF HEADACHE, DIZZINESS, LOSS OF MUSCULAR CONTROL, APPARENT DROWSINESS, AND COMA. PERMANENT BRAIN DAMAGE OR DEATH CAN RESULT FROM SEVERE EXPOSURE.

CARBON MONOXIDE OCCURS IN THE EXHAUST FUMES OF FUEL-BURNING HEATERS AND INTERNAL COMBUSTION ENGINES AND BECOMES DANGEROUSLY CONCENTRATED UNDER CONDITIONS OF INADEQUATE VENTILATION. THE FOLLOWING PRECAUTIONS MUST BE OBSERVED TO ENSURE THE SAFETY OF PERSONNEL WHENEVER THE PERSONNEL HEATER, MAIN, OR AUXILIARY ENGINE OF ANY VEHICLE IS OPERATED FOR MAINTENANCE PURPOSES OR TACTICAL USE.

1. DO NOT operate heater or engine of vehicle in an enclosed area unless it is ADEQUATELY VENTILATED.
2. DO NOT idle engine for long periods without maintaining ADEQUATE VENTILATION in personnel compartments.
3. DO NOT drive any vehicle with inspection plates, cover plates, or engine compartment doors removed unless necessary for maintenance purposes.
4. BE ALERT at all times during vehicle operation for exhaust odors and exposure symptoms. If either are present, IMMEDIATELY VENTILATE personnel compartments. If symptoms persist, remove affected personnel from vehicle and treat as follows: expose to fresh air; keep warm; DO NOT PERMIT PHYSICAL EXERCISE; if necessary, administer artificial respiration.

THE BEST DEFENSE AGAINST CARBON MONOXIDE POISONING IS ADEQUATE VENTILATION.

WARNING

- Operators are reminded to observe basic safe driving techniques/skills when operating the vehicle. Vehicle speed must be reduced consistent with weather and road terrain conditions. Failure to use basic safe driving techniques/skills may result in damage to equipment, injury to personnel, or death.
- The driver's hatch cover must be secured in either the stowed or closed position when operating the vehicle. Failure to comply may result in injury to personnel.

WARNING - CONTINUED

- Keep all parts of body from between hatch cover and hatch while opening or closing hatch cover. Hatch cannot be closed without standing. Ensure that inner handle is not stuck in open or upward position. Hatch cover detent locks will not engage unless inner handle is in closed or downward position. Failure to comply may result in severe injury to personnel.
- Close driver's hatch cover before firing smoke grenades. Failure to comply may result in severe injury to personnel.
- Smoke grenades can travel 410 ft (125 m) after firing. Fire smoke grenades only in authorized areas. Failure to comply may result in injury to personnel.
- If misfired smoke grenades fire during unloading, they can cause severe injuries. NEVER place any part of your body in front of smoke grenade launchers.
- Smoke grenades can explode and burn, and cause severe injuries and fires. Electricity and heat can cause smoke grenades to explode. Make sure ARM OFF switch of smoke grenade arming firing unit and vehicle MASTER SWITCH are set to OFF before loading smoke grenades. Do not place smoke grenades on or near heat or heated surface.
- Smoke grenade launchers use an electrical firing pin. Do not work on smoke grenade dischargers or smoke grenade launcher tubes unless MASTER SWITCH and ARM OFF switch of smoke grenade arming firing unit are set to OFF. Failure to comply may result in injury to personnel.
- Do not operate ejector when personnel are in bowl. Do not work in bowl unless ejector lock is engaged. Failure to comply may result in severe injury to personnel.
- Do not stand or work in bowl area unless ejector lock is engaged. Failure to comply may result in severe injury to personnel.
- Do not work under vehicle unless hull is blocked and apron lockpins are installed. Failure to comply may result in severe injury to personnel or death.
- Do not stand or work under raised apron assembly unless apron lockpins are installed. Apron assembly can drop, causing severe injury to personnel or death.
- Block track or roadwheels when parking brake is released. Vehicle can roll, causing damage to equipment, severe injury to personnel, or death.
- The NBC system of the M9 ACE, or of the MCS unit (if installed), will not protect against carbon monoxide. Failure to take precaution may result in severe injury to personnel or death.
- The NBC protection filters of the M9 ACE, or of the MCS unit (if installed), use a type of carbon that contains chromium VI. This is a known carcinogen if inhaled or swallowed. Damaged or unusable filters are classified as hazardous waste.
 - Do not throw away damaged or unusable filters as trash.
 - Turn in damaged or unusable filters to your hazardous waste management office or Defense Reutilization and Marketing Office (DRMO).

WARNING – CONTINUED

- Filters are completely safe to handle and use if they are not damaged in such a way that carbon leaks from them. If carbon does leak, use protection such as a dust respirator to cover nose and mouth and put carbon in a container such as a self-sealing plastic bag; turn it in to hazardous waste management office or DRMO. Disposal of hazardous waste is restricted by law. Violation is subject to criminal penalties.
- If NBC exposure is suspected, all air filter media of the M9 ACE, or of the MCS unit (if installed), should be handled by personnel wearing protective equipment. Consult your unit NBC officer or NBC NCO for appropriate handling or disposal instructions.
- NBC contaminated filters can only be handled and disposed of by trained personnel. Personnel must use protective clothing (FM 3-4) and follow appropriate decontamination procedures (FM 3-5). Follow unit SOP for final disposal of contaminated filters.
- DS2 is combustible. DS2 can also severely burn the skin, cause blindness, or deteriorate the battle dress and chemical protective overgarments. Do not use DS2 near an open flame, in confined spaces, or allow it to touch skin or clothing. Personnel handling DS2 must wear protective clothing and eye protection.
- Fuel is a combustible material. Do not smoke or allow sparks or open flames into areas where fuel is present. Failure to comply may result in severe injury to personnel or death. If injured, seek medical attention immediately.
- Prolonged breathing of fuel vapors can be fatal. If eyes or skin become irritated by fuel, flush with water.
- Drycleaning solvent is flammable and will not be used near open flame. A fire extinguisher will be kept nearby when the solvent is used. Use only in well-ventilated places. Failure to comply may result in damage to equipment or injury to personnel.
- Radiator and related components may be very hot. Do not work on cooling system until it is cool. Failure to comply may result in severe injury to personnel.
- Under no circumstances should any cover or grille leading to the engine compartment be opened when a fire exists. Failure to comply may result in severe injury to personnel.
- Remove all jewelry, such as rings, dog tags, bracelets, etc. If jewelry or disconnected battery ground cable contacts battery terminal, a direct short will result, causing instant heating of tools, damage to equipment, and severe injury to personnel.
- Do not smoke, have open flames, or make sparks around batteries. The batteries can explode and injure you.
- Electrolyte is extremely harmful. Always wear safety goggles and rubber gloves when performing battery maintenance. Injury will result if electrolyte contacts eyes or skin.
- Always wear leather gloves when handling wire rope. Never allow wire rope to run through hands. Broken or frayed wires may cause severe injury to personnel.
- Stand clear of wire rope. Should wire rope break or snap loose, severe injury to personnel or death may result.
- Do not operate winch with one or more cable strands kinked or broken. Failure to comply may result in severe injury to personnel or death.

WARNING – CONTINUED

- Wear safety goggles when using hammer with driftpin or track pin. Failure to comply may result in injury to personnel.
- Antenna adds an extra 9-1/2 ft (2.9 m) to the vehicle clearance. Always check the area to be worked in for powerlines, their height, and power poles or towers. Do not stop your vehicle under powerlines. If you are not sure the antenna will clear a powerline, stop before you get too close to the powerline and either tie down the antenna or remove antenna sections to make sure you can proceed safely. Failure to comply may result in damage to equipment or injury to personnel.
- Compressed air can injure you and others. Do not aim compressed air hoses at anyone. Do not use more pressure than 30 psi (207 kPa). Always wear goggles.
- Do not use top deflector as a step. Failure to comply may result in damage to equipment or injury to personnel.
- When folding dozer blade, work on blade latches from side of vehicle only. Do not stand in front of dozer blade while retracting ejector. Failure to comply may result in severe injury to personnel.
- Use caution when loading/unloading smoke grenade launchers. Vehicle cowling, ejector, and bowl surfaces may be slippery. Step on non-skid areas only. Failure to comply may result in serious injury to personnel.
- this vehicle has been designed to operate safely and efficiently within the limits specified in the TM. Operation beyond these limits is prohibited IAW AR 70-1 without written approval from the Commander, U.S.Army Tank-automotive and Armaments Command, ATTN: AMSTA-PM-CS Warren, MI 48397-5000.

LIST OF EFFECTIVE PAGES/WORK PACKAGES

NOTE: The portion of test or illustration effected by the updates is indicated by a vertical line in the outer margin of the page. Updates to wiring diagrams are indicated by shaded areas.

Dates of issue for original and updated pages/work packages are:

Original ..0..26 JUN 92
 Change ..1..29 SEP 93
 Change ..2..15 MAY 96
 Change ..3..16 NOV 98
 Change ..4..30 JUN 99
 Change ..5..27 MAR 00

**TOTAL NUMBER OF PAGES FOR FRONT AND REAR MATTER IS 35 AND
 TOTAL NUMBER OF PAGES IS 288 CONSISTING OF THE FOLLOWING:**

Page/WP No.	Change No.	Page/WP No.	Change No.	Page/WP No.	Change No.
Cover	5	2-15	5	2-39 to 2-40	2
a	3	2-16	2	2-41 to 2-42	3
b-c	2	2-17 to 2-18	1	2-43 to 2-44	5
d	3	2-19	3	2-45	0
List of Effective Pages	5	2-20	1	2-46 to 2-47	3
i	4	2-21	3	2-48 to 2-50	5
ii	3	2-22	1	2-51	0
1-1	3	2-23 to 2-25	5	2-52	2
1-2	2	2-26	1	2-53	5
1-3	3	2-27	5	2-54	3
1-4 to 1-6	5	2-28 to 2-29	4	2-55	5
1-7	1	2-30	5	2-56 to 2-57	2
1-8 to 1-12	5	2-30.1	2	2-58	5
2-1 to 2-2	5	2-30.2	1	2-59	2
2-3	3	2-30.3	3	2-60 to 2-62	5
2-4	5	2-30.4 to 2-30.5	1	2-63 to 2-64	2
2-5	4	2-30.6	2	2-65	0
2-6 to 2-8	0	2-30.7	5	2-66 to 2-67	2
2-8.1 to 2-8.2	4	2-31	3	2-68 to 2-69	5
2-9	0	2-32	0	2-70	2
2-10	1	2-33	3	2-71	5
2-10.1 to 2-11	1	2-34	0	2-72	0
2-12	5	2-35	2	2-73	5
2-13	1	2-36	5	2-74	2
2-14	2	2-37	0	2-74 to 2-76	5
		2-38	5	2-77	1

*Zero in this column indicates an original page or work package.

TM 5-2350-262-10

Page/WP No.	Change No.	Page/WP No.	Change No.
2-78	3	3-26 to 3-27.2	4
2-79 to 2-82	5	3-28 to 3-30	0
2-83	2	3-31 to 3-36	3
2-84	0	A-1	3
2-85	0	A-2	5
2-86	0	B-1	0
2-86.1 to 2-86.4	2	B-2	2
2-87 to 2-90	0	B-3	3
2-91 to 2-92	5	B-4	5
2-94	4	B-5	3
2-95	0	B-6 to B-7	2
2-96 to 2-100	3	B-8	3
2-101	2	B-9 to B-10	2
2-102	5	B-11	3
2-103	3	B-12	4
2-104 to 2-105	5	B-13 to B-16	3
2-106 to 2-111	3	B-17 to B-18	2
2-112 to 2-118	2	C-1	0
2-119 to 2-121	5	C-2 to C-3	2
2-122	2	C-4	5
2-123	5	D-1	0
2-124	0	D-2	1
3-1	3	D-3 to D-6	0
3-2	0	E-1 to E-2	3
3-3 to 3-4	1	F-1 to F-10	3
3-5	0	F-11	5
3-6	3	F-12 to F13	3
3-7	1	F-14	5
3-8 to 3-10	3	F-15 to F-20	3
3-11 to 3-12	0	F-21	5
3-13	5	F-22 to F-24	3
3-14	3	F-25 to F-26	5
3-15	2	F-27 to F-31	3
3-16	1	F-32 to F-35	5
3-17	0	F-36 to F-40	3
3-18 to 3-19	1	INDEX 1	4
3-20	0	INDEX 2	2
3-21	1	INDEX 3	3
3-22	5	INDEX 4	4
3-22.1 to 3-22.2	2	Rear Cover	5
3-23	0		
3-24	1		
3-25	3		

**OPERATOR'S MANUAL
 ARMORED COMBAT EARTHMOVER (ACE), M9**

REPORTING ERRORS AND RECOMMENDING IMPROVEMENTS

You can help improve this publication. If you find any mistakes or if you know of a way to improve the procedures, please let us know. Submit your DA Form 2028-2 (Recommended Changes to Equipment Technical Publications), through the Internet, on the Army Electronic Product Support (AEPS) website. The Internet address is <http://aeps.ria.army.mil>. If you need a password, scroll down and click on "ACCESS REQUEST FORM". The DA Form 2028 is located in the ONLINE FORMS PROCESSING section of the AEPS. Fill out the form and click on SUBMIT. Using this form on the AEPS will enable us to respond quicker to your comments and better manage the DA Form 2028 program. You may also mail , fax or email your letter, DA Form 2028, or DA Form 2028-2 direct to: Commander, U.S. Army Tank-automotive and Armaments Command, ATTN: AMSTA-AC-NML, Rock Island, IL 61299-7630. The email address is amsta-ac-nml@ria.army.mil. The fax is DSN 793-0726 or Commercial (309) 782-0726.

TABLE OF CONTENTS

CHAPTER 1	INTRODUCTION	1-1
Section I	General Information	1-1
Section II	Equipment Description	1-3
CHAPTER 2	OPERATING INSTRUCTIONS	2-1
Section I	Description and Use of Operator's Controls and Indicators	2-1
Section II	Preventive Maintenance Checks and Services	2-9
Section III	Operation Under Usual Conditions	2-32
Section IV	Operation Under Unusual Conditions	2-95
CHAPTER 3	MAINTENANCE INSTRUCTIONS	3-1
Section I	Lubrication Instructions	3-1
Section II	Troubleshooting	3-2
Section III	Maintenance Procedures	3-13
Section IV	Maintenance Auxiliary Equipment	3-29
APPENDIX A	REFERENCES	A-1
APPENDIX B	COMPONENTS OF END ITEM AND BASIC ISSUE ITEMS LISTS ...	B-1
APPENDIX C	ADDITIONAL AUTHORIZATION LIST	C-1
APPENDIX D	EXPENDABLE SUPPLIES AND MATERIALS LIST	D-1
APPENDIX E	STOWAGE AND SIGN GUIDE	E-1
APPENDIX F	LUBRICATION INSTRUCTIONS	F-1
INDEX	INDEX 1

*This publication supersedes TM 5-2350-262-10 dated October 1990.

HOW TO USE THIS MANUAL

This manual is designed to help you operate and maintain the M9 Armored Combat Earth-mover. Listed below are special features which have been included to make it easier to locate and use the information you need.

- A front cover Table of Contents is provided, giving you a quick reference to chapters and sections you will be using often.
- Warnings, subject headings, and procedural steps are highlighted in bold print so that they are easy to locate.

BECOME FAMILIAR WITH THIS MANUAL BEFORE OPERATING THE M9

This manual is arranged in the order that you will need the information about the M9. The following major sections, or chapters, include all the information that you, the operator, must be familiar with.

- **Warnings** – Warnings you should observe while operating or performing operator maintenance are shown in the front part of the manual. These are only the most frequently encountered warnings. These are also repeated in the parts of the book where they apply.
- **Table of Contents** – The contents of the three chapters and the appendices are listed here.
- **Chapter 1** – This chapter covers general information and descriptions of the vehicle and vehicle systems.
- **Chapter 2** – This chapter describes how to operate the M9, in both usual and unusual conditions, and what to check or inspect before, during, and after operating the vehicle.
- **Chapter 3** – This chapter contains the maintenance instructions and procedures for which the operator is responsible.
- **Appendix A** – This appendix lists references, such as technical manuals and other publications, to which you may need to refer.
- **Appendix B** – This appendix illustrates and lists the Components of End Item and Basic Issue Items.
- **Appendix C** – This appendix illustrates and lists the Additional Authorization List items.
- **Appendix D** – This appendix lists the Expendable Supplies and Materials you will need.
- **Appendix E** – This appendix depicts and lists the stowage areas and signs to which you should be aware.
- **Appendix F** – This appendix depicts and lists instructions for you to lubricate the M9.

**CHAPTER 1
INTRODUCTION**

Section I. General Information 1-1
Section II. Equipment Description 1-3

Section I. GENERAL INFORMATION

SCOPE

This manual is for use in operating and maintaining the M9 Armored Combat Earthmover (ACE).

- Chapter 1 contains general information, description, and data on the M9.
- Chapter 2 depicts and describes the controls and indicators, Preventive Maintenance Checks and Services (PMCS), and operation of the M9.
- Chapter 3 contains lubrication instructions, troubleshooting, and maintenance procedures.
- Appendices A through F list references, including Components of End Item (COEI), Basic Issue Items (BI), Additional Authorization List (AAL), Expendable Supplies and Materials List, Stowage and Sign Guide, and Lubrication Instructions.

MAINTENANCE FORMS AND RECORDS

Department of the Army forms and procedures used for equipment maintenance will be those prescribed by DA Pam 738-750, The Army Maintenance Management System (TAMMS).

EQUIPMENT IMPROVEMENT REPORT AND MAINTENANCE DIGEST (EIR MD)

The quarterly or semiannual Equipment Improvement Report and Maintenance Digest, TB 43-0001-39 series, contains valuable field information on the equipment covered in this manual. The information in the TB 43-0001-39 series is compiled from some of the Equipment Improvement Reports (EIR's) that you prepared on the vehicle covered in this manual. Many of these articles resulted from comments, suggestions, and improvement recommendations that you submitted to the EIR program. The TB 43-0001-39 series contains information on equipment improvements, minor alterations, proposed Modification Work Orders (MWO's), warranties (if applicable), actions taken on some of your DA Form 2028's (Recommended Changes to Publications), and advance information on proposed changes that may affect this manual. The information will help you in doing your job better and will help in keeping you advised of the latest changes to this manual. Also refer to DA Pam 25-30, Consolidated Index of Army Publications and Blank Forms, and Appendix A, References, of this manual.

HAND RECEIPT (-HR MANUALS)

This manual has a companion document with a TM followed by "-HR" (which stands for Hand Receipt). The TM 5-2350-262-10-HR consists of preprinted hand receipts (DA Form 2062) that list end item related equipment (i.e., COEI, BII, and AAL) that you must account for. As an aid to property accountability, additional -HR manuals may be requisitioned from the following source in accordance with procedures in chapter 3, AR 310-2.

The U.S. Army Adjutant General Publications Center
Attn: AGLD-OD
1655 Woodson Road
St. Louis, MO 63114

REPORTING EQUIPMENT IMPROVEMENT RECOMMENDATIONS (EIR's)

If your M9 ACE vehicle needs improvement, let us know. Send us an EIR. You, the user, are the only one who can tell us what you don't like about your equipment. Let us know why you don't like the design or performance. Put it on a SF368 (Quality Deficiency Report). Mail it to us at: Commander, U.S. Army Tank-Automotive and Armaments Command, ATTN: AMSTA-TR-E/MPA/267, Warren, MI 48397-5000. We'll send you a reply.

Section II. EQUIPMENT DESCRIPTION

EQUIPMENT CHARACTERISTICS, CAPABILITIES, AND FEATURES

PURPOSE

The M9 is an armored combat earthmover used for:

- Bulldozing
- Rough grading
- Excavating
- Hauling
- Scraping

It is a multi-purpose vehicle and is also used as an:

- Earth hauler
- Cargo carrier
- Prime mover

CAPABILITIES AND FEATURES

- Full tracked
- Air transportable
- Highly mobile
- Armored
- Travels on land at up to 30 mph (48.3 km/h). Maximum speed for this vehicle is 30 mph on hard, level surface and will vary in other soil conditions.
- Climbs up to 60 percent grades.
- Drawbar pull of 31,000 lb (14,074 kg) at 1.5 mph (2.4 km/h)
- Smoke grenade launchers

LOCATION AND DESCRIPTION OF MAJOR COMPONENTS

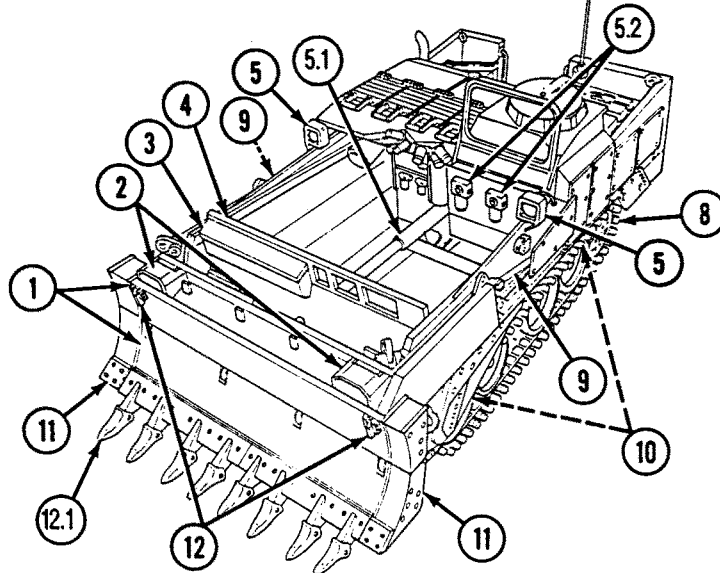

- (1) APRON AND DOZER ASSEMBLY. Used for earthmoving operations. Can be raised, or lowered to load or unload material or cargo.
- (2) HEADLIGHTS. Provide light for night driving. Include blackout and infrared lights.
- (3) STOWAGE BOX. Used to stow Basic Issue Items (BII) and Additional Authorization List (AAL) items.
- (4) EJECTOR. Moves back and forth in bowl to discharge material, load or unload palletized cargo, and fold the dozer blade.
- (5) FLOODLIGHTS. Provide light for night operations.
- (5.1) DEBRIS SHIELD. Prevents debris from accumulating on hose assemblies and fittings in lower bowl area.
- (5.2) HIGH-PRESSURE FILTERS. Provide increased filtration and ease of maintenance with pop-out indicators, spin-off filters, and replaceable filter elements.
- (6) Deleted
- (7) Deleted
- (8) TRACK. Consists of rubber-padded steel track shoes and is driven by the sprockets.
- (9) APRON CYLINDER. Raises and lowers apron and dozer assembly.
- (10) TRACK WEAR PLATES. Replaceable steel plates keep track from wearing welded parts on the aluminum hull.

NOTE

NEW PRODUCTION vehicles are equipped with a steel dozer blade and extensions. Aluminum dozer blade and extensions are shown.

- (11) APRON AND DOZER EXTENSIONS. Provide a larger working surface for apron and dozer. May be removed for transporting vehicle.
- (12) DOZER/RIPPER BLADE LATCHES. Reusable pin assembly locks dozer/ripper blade, in folded position during long motor marches and cross-country driving.
- (12.1) RIPPER BLADE. Provides ease of digging in hard-packed soils (if installed).

LOCATION AND DESCRIPTION OF MAJOR COMPONENTS — CONTINUED

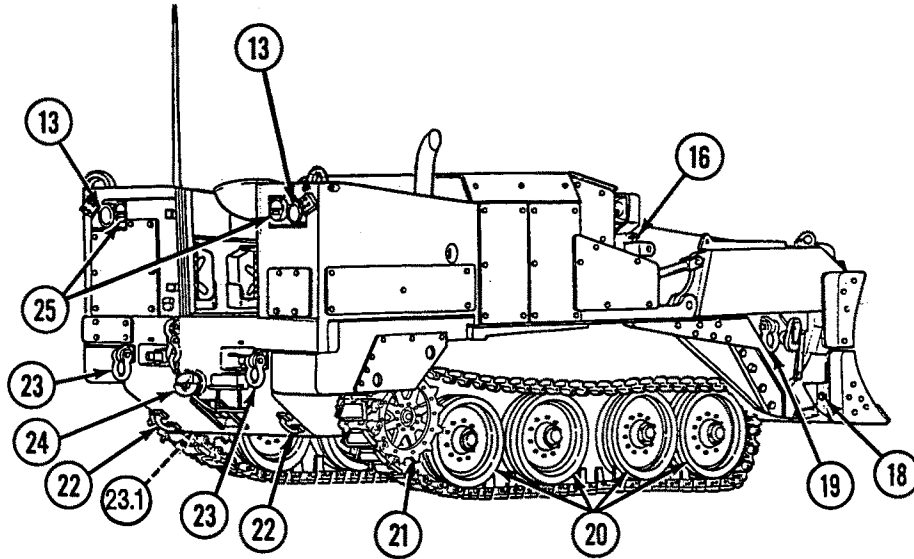

- (13) REAR FLOODLIGHTS. Provide light at rear of vehicle for night operations.
- (14) Deleted
- (15) Deleted
- (15.1) Deleted
- (16) UPPER APRON LOCKPINS. Lock apron in raised position as a safety precaution during maintenance.
- (17) Deleted
- (18) DOZER LOCKPINS. Secure dozer/ripper blade to apron.
- (19) TIEDOWN SHACKLES. Provided to secure the vehicle during air and surface transportation.
- (20) ROADWHEELS. Provide support and guide for the tracks and suspension of the vehicle.
- (21) SPROCKETS. Mounted to the final drives to drive the track.
- (22) TIEDOWN BRACKETS. Provided to secure the vehicle during air and surface transportation.
- (23) TOW SHACKLES. Used to attach tow cable, or chain, for towing or recovery operations. Also used to secure the vehicle during ground transportation.
- (23.1) HULL PROTECTIVE PLATES. Protect hull underside from damage during digging operations.
- (24) TOWING PINTLE. Used during towing operations to attach tow bar or to tow trailer.
- (25) TAILLIGHTS. Used for night driving and to indicate when vehicle brakes are used.

LOCATION AND DESCRIPTION OF MAJOR COMPONENTS — CONTINUED

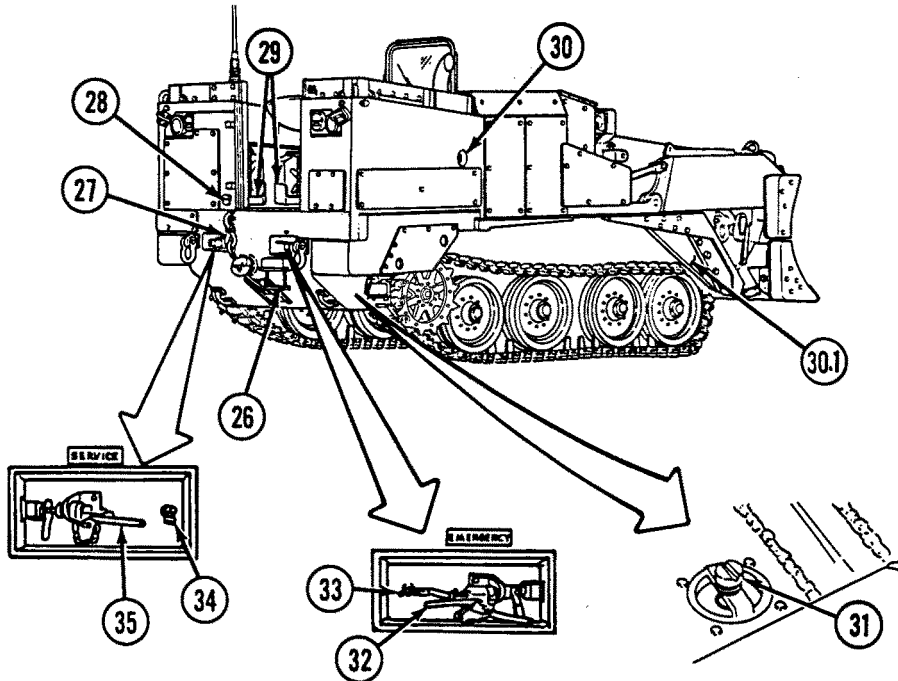

- (26) REAR STEP. Used to enter the vehicle.
- (27) WINCH ASSEMBLY. Mounted in the rear hull and may be used in recovery operations.
- (28) TRAILER ELECTRICAL RECEPTACLE: Supplies electrical power to towed trailer.
- (29) LIQUID CONTAINER BRACKETS. Provides stowage for 5-gal. (19 L) liquid container and 15-qt (14 L) decon apparatus.
- (30) EXTERNAL FIRE EXTINGUISHER HANDLE. Activates fixed fire extinguisher system from outside the vehicle.
- (30.1) TRACK RETAINERS. Keep tracks on sprockets, when suspension is lowered, for earthmoving operations.
- (31) HULL DRAIN VALVE. By pushing on drain valve and turning lock open, allows water to drain from rear of hull.
- (32) TRAILER EMERGENCY BRAKE AIR COUPLING. Supplies compressed air to emergency brake system of towed trailer.
- (33) FUEL DRAIN VALVE. Drains fuel/water separator and fuel tank.
- (34) AIR RESERVOIR DRAIN VALVE. When pressed, drains air and moisture from the compressed air reservoir.
- (35) TRAILER BRAKE COUPLING. Provides compressed air for brakes of towed trailer.

LOCATION AND DESCRIPTION OF MAJOR COMPONENTS — CONTINUED

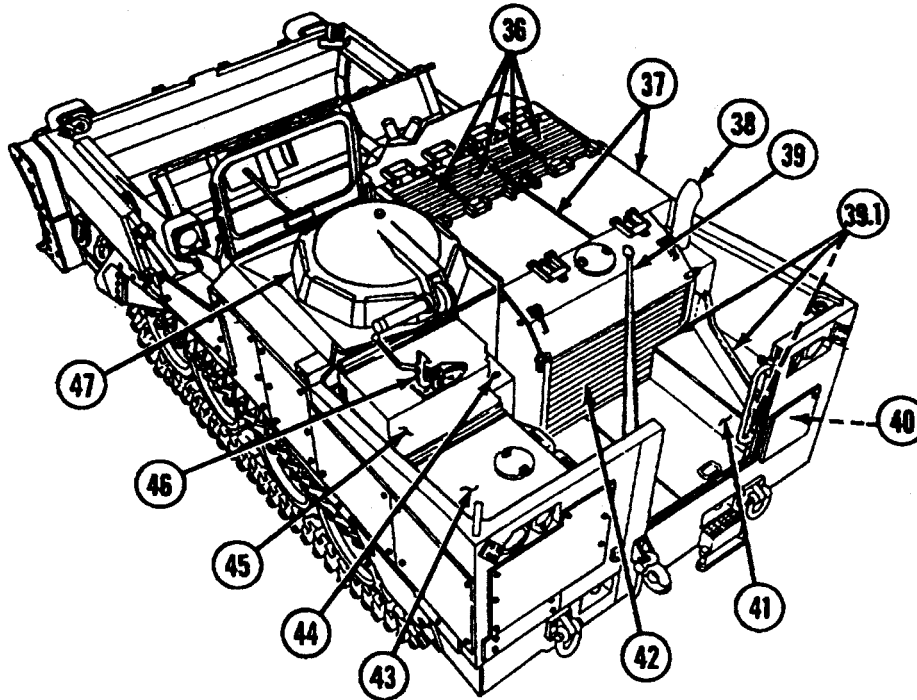

- (36) INTAKE GRILLES. Louvered armor plates provide passage of air for engine cooling while protecting engine and engine components from projectiles.
- (37) ACCESS COVERS. Non-louvered armor plates to protect engine.
- (38) MUFFLER. Reduces noise level of vehicle exhaust system.
- (39) ANTENNA. Allows transmission and reception for the vehicle radio.
- (39.1) BATTERY BOX DEFLECTORS. Deflect radiator hot air flow away from battery box, preventing boil-over in high ambient temperatures.
- (40) SLAVE RECEPTACLE. Connector for slave starting the vehicle from an external source.
- (41) BATTERY BOX. Protects the four vehicle batteries.
- (42) EXHAUST GRILLES. Louvered armor plates provide passage of air for engine cooling while protecting radiator from projectiles.
- (43) FUEL TANK. Contains fuel for vehicle engine operation.
- (44) HYDRAULIC OIL FILL PORT. Primary fill point for servicing the vehicle hydraulic tank.
- (45) RADIO BOX. Provides protection for the radio.
- (46) HATCH COVER LATCH. Used during noncombat situations to hold down open hatch cover to prevent accidental closing of hatch cover.
- (47) DRIVER'S HATCH ASSEMBLY. Armored cover for driver's compartment. Contains eight vision blocks and can be latched open or locked closed.

LOCATION AND DESCRIPTION OF MAJOR COMPONENTS — CONTINUED

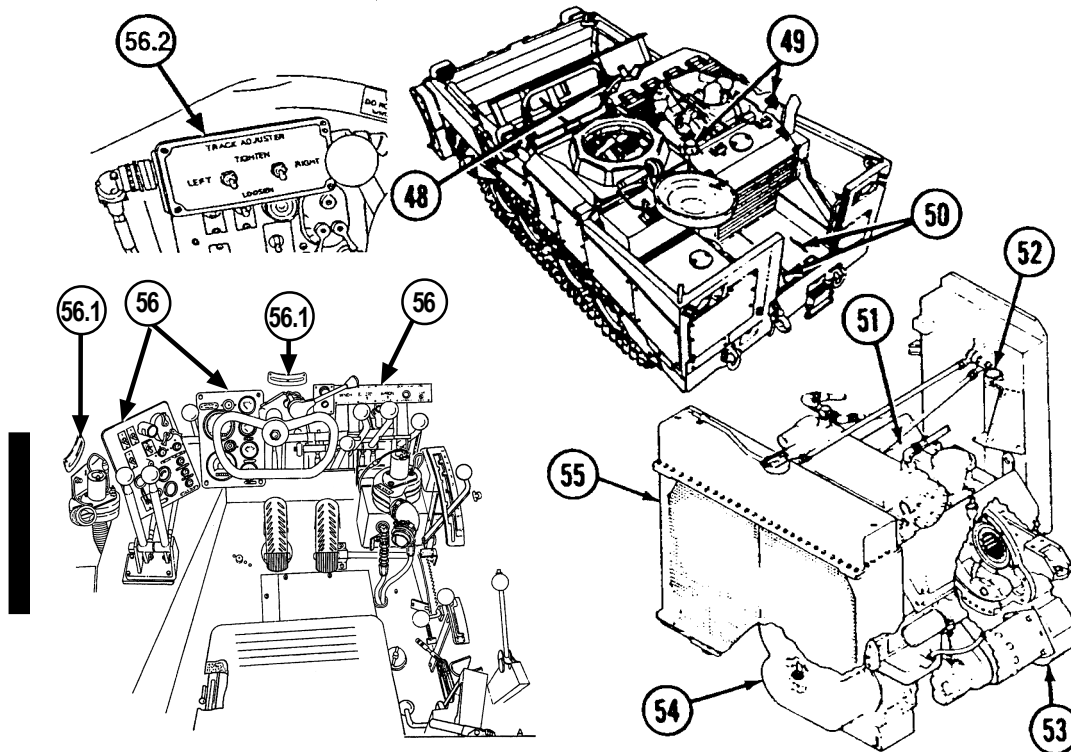

- (48) SMOKE GRENADE LAUNCHERS. Launch smoke grenades when required by the tactical situation. See p E-2 for smoke grenade stowage locations.
- (49) FIXED FIRE EXTINGUISHER SYSTEM. Puts out fire in engine compartment. May be activated by a handle in driver's compartment or on outside of hull.
- (50) REAR FLOOR PLATES. Floor plates lift out for access to systems and components under floors in rear hull of vehicle.
- (51) ENGINE. Provides power to operate the vehicle and all vehicle subsystems.
- (52) ENGINE COLD START SYSTEM. Aids in starting vehicle engine in cold weather.
- (53) TRANSFER CASE. Couples power from the engine to the drivetrain, and drives hydraulic and oil pumps.
- (54) TRANSMISSION. Transmits engine power to the drivetrain.
- (55) RADIATOR. Keeps engine at proper operating temperature.
- (56) DRIVER'S CONTROLS AND INDICATORS. Used by operator to drive the vehicle and perform earthmoving operations.
- (56.1) INCLINOMETERS. Front inclinometer indicates vehicle side slope. Side inclinometer indicates the grade the vehicle is climbing or descending.
- (56.2) SEMI-AUTOMATIC TRACK ADJUSTER CONTROL PANEL (NEW PRODUCTION). Provides the capability of adjustment and semi-automatic control of the track tension from within the driver's compartment.

LOCATION AND DESCRIPTION OF MAJOR COMPONENTS — CONTINUED

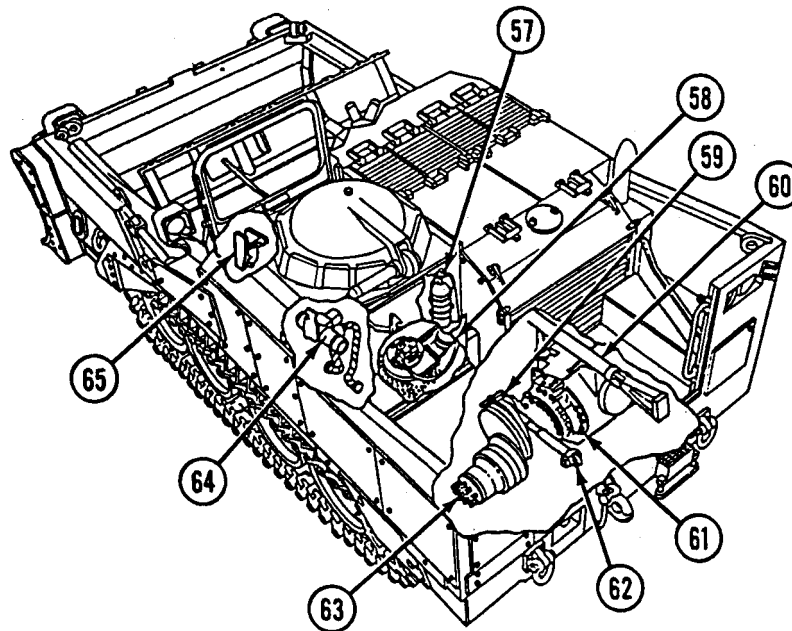

- (57) PORTABLE FIRE EXTINGUISHER. Used by operator to put out fires in or around the vehicle.

NOTE

Although the Bilge Pump is considered Not Mission Essential and will no longer be supported with spare and repair parts, this manual contains operational procedures For Your Information Only. Notify Unit maintenance if the bilge pump no longer operates.

- (58) BILGE PUMP. Discharges water from hull of vehicle during operation.
- (59) FUEL SHUT-OFF VALVE. Controls fuel flow.
- (60) EJECTOR CYLINDER. Moves ejector forward and back.
- (61) STEER UNIT. Transmits power from transmission to final drives. Also controls tracks for steering and braking of vehicle.
- (62) TRACK ADJUSTING CYLINDER. Moves adjusting flange of final drive fore and aft to adjust track tension (one on each side).
- (63) FINAL DRIVES. Transmit power from steer unit to drive sprockets (one on each side).
- (64) NBC INSTALLATION. Provides driver protection from nuclear, biological, and chemical contaminants. If MCS unit is installed, the NBC equipment is removed, but driver protection is provided by the MCS unit's own NBC equipment.
- (65) BUMP STOPS (RETRACTABLE). Limit upward travel of both front roadwheel arms when in sprung position (one on each side).

EQUIPMENT DATA

GENERAL

Weight (net)	37,000 lb (16,769 kg)
Weight (gross)	55,000 lb (24,927 kg)
Length	20 ft 5 in. (622 cm)
Length (dozer blade folded)	20 ft 3 in. (617 cm)
Height	8 ft 9 in. (267 cm)
Width (extensions installed)	10 ft 5 in. (318 cm)
Width (extensions removed)	9 ft 2 in. (279 cm)
Ground Clearance SPRUNG (engine running)	13 in. (33 cm)
Ground Clearance UNSPRUNG	Variable
Ground Pressure	9.5 psi (66 kPa)
Bridge Classification	17 ton (15 t)

LAND PERFORMANCE

Maximum Speed	30 mph (48 km/h)
Cruising Range (secondary roads)	230 mi (370 km)
Grade Ascending Ability — with 18,000 lb (8,172 kg) in bowl	60%
Grade Descending Ability — with 18,000 lb (8,172 kg) in bowl	60%
Gradeability — with 4,000 lb (1,816 kg) in bowl	30%
Gradeability (curb weight)	20%
Trench Width	5 ft 2 in. (157 cm)
Vertical Wall	1 ft 6 in. (46 cm)
Tilt Dozing	5 degrees
Side Slope Limit (curb weight)	20%
Side Slope Limit — with 4,000 lb (1,816 kg) load	30%
Side Slope Limit — with 18,000 lb (8,172 kg) load	40%
Drawbar Pull	31,000 lb (14,074 kg)
Bowl Capacity	8.7 cu yd (67 cu m)
Fording Depth	36 in. (91 cm)
Turning Radius (geared steer mode)	45 ft (14 m)
Turning Radius (clutch brake mode)	Pivots
Angle of Departure (maximum) SPRUNG	27° grade
Angle of Approach (maximum)	29° grade

WATER PERFORMANCE

Deleted

CAPACITIES

Fuel Tank	134 gal. (507 L)
Fuel Type	Diesel oil, 40 cetane, VV-F-800
Regular Grade (DF-2)	Above +10°F (-12°C)
Winter Grade (DF-1)	Below +10°F (-12°C) to above -20°F (-29°C)
Arctic Grade (DF-A)	Below -20°F (-29°C)
Aviation Turbine (JP8)	Above -60°F (-51°C)

EQUIPMENT DATA - CONTINUED

CAPACITIES - CONTINUED

Engine Oil, Dry	30 qt (28 L)
Engine Oil, Refill	18 qt w/o filters (17 L)
	22 qt w/ filters (21 L)
Engine Coolant:	
Refill	94 qt (89 L)
Radiator Capacity	79 qt (47 L)
Final Drives (each)	8 qt (7.6 L)
Hydraulic Oil Tank:	
Dry	128 qt (121 L)
Refill	108 qt (102 L)
Return Line Filter	4 qt (3.8 L)
Winch	3.5 qt (3.3 L)

ENGINE

Manufacturer	Cummins Engine Company, Inc.
Model	V903C
Displacement	903 cu in.
Type	8-cylinder, 4-cycle diesel
Horsepower (@2,600 rpm)	295

TRANSMISSION

Manufacturer	Clark Equipment Co.
Model	13.5 HR 3610-2
Type	Torque converter
Shift Selection	Manual
Shift Ranges	6 forward, 2 reverse

STEER UNIT

Manufacturer	Twin Disc Inc.
Type	Hydraulic with gears and clutches
Modes	Geared steer and clutch brake

WINCH (25,000 lb (11,350 kg))

Deleted

WINCH (35,000 LB (15,890 kg))

Manufacturer	Lake Shore
Type	Planetary
Wire Rope Length	206 ft ± 2 ft (63 m ± 0.6)
Wire Rope Diameter	3/4 in. (19.1 mm)
Line Pull	35,000 lb ± 1,500 lb
	(15,890 kg ± 681 kg)
Spooling Rate (Low Range)	8.5 ft/min. (2.6m) min.
Spooling Rage (High Range)	36 ft/min. (11 m) max.
Winch Motor:	
Type	Gear, Geroter or Vane

CHAPTER 2
OPERATING INSTRUCTIONS

Section I. Description and Use of Operator's Controls and Indicators 2-1
Section II. Preventive Maintenance Checks and Services (PMCS) 2-9
Section III. Operation Under Usual Conditions 2-32
Section IV. Operation Under Unusual Conditions 2-95

**Section I. DESCRIPTION AND USE OF OPERATOR'S
CONTROLS AND INDICATORS**

KNOW VEHICLE CONTROLS AND INDICATORS

Do not attempt to operate equipment until becoming familiar with the location and use of all controls and indicators. The following pages describe the controls and indicators in use.

NOTE

Although the Bilge Pump is considered Not Mission Essential and will no longer be supported with spare and repair parts, this manual contains operational procedures For Your Information Only. Notify Unit maintenance if the bilge pump no longer operates.

DRIVER'S CONTROLS AND INDICATORS

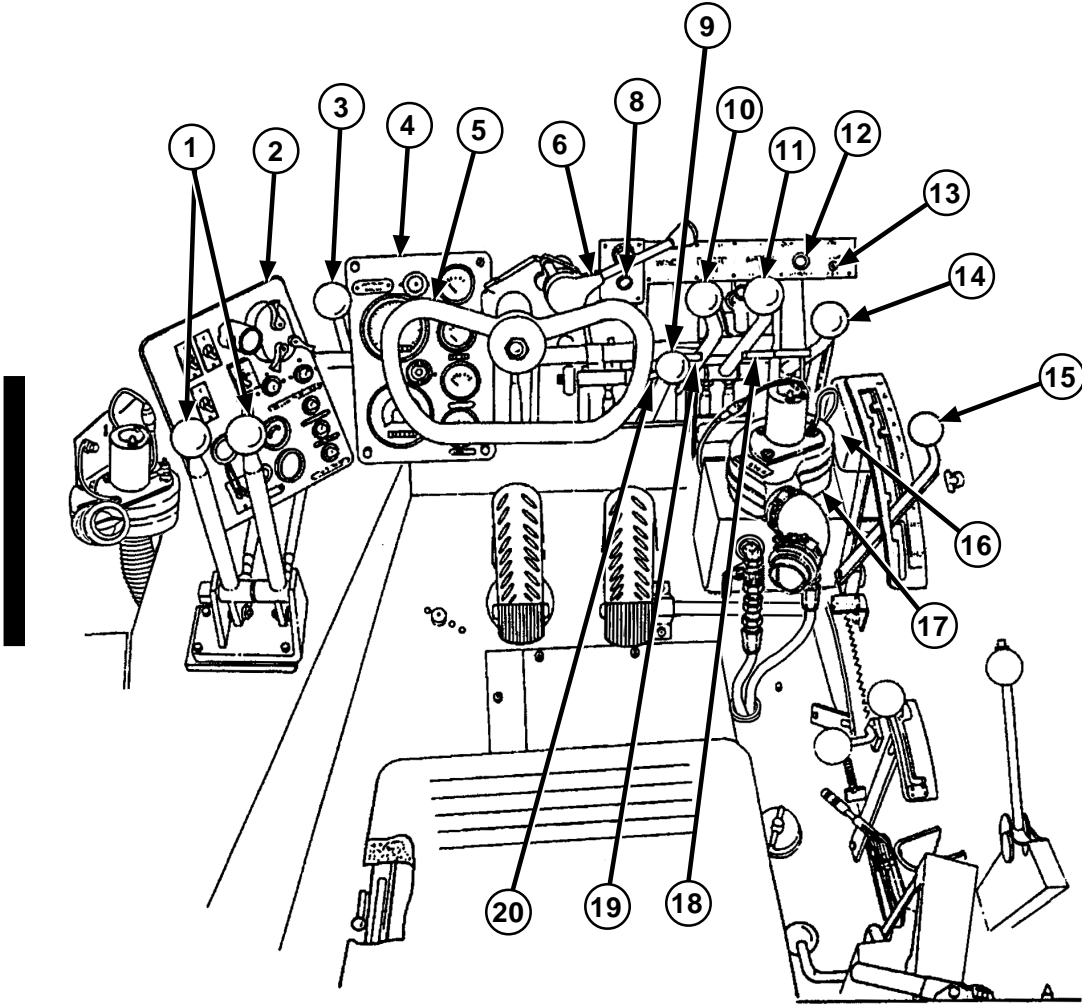

DRIVER'S CONTROLS AND INDICATORS — CONTINUED

Key	Control or Indicator	Function
1	Suspension Control Levers (left and right)	Raise or lower left or right side of vehicle for dozing operation.
2	Switch Panel	See page 2-6.
3	Suspension SPRUNG/ UNSPRUNG Lever	Used to set suspension in SPRUNG or UNSPRUNG mode of operation.
4	Gage Panel	See page 2-8.
5	Steering Wheel	Turns vehicle left (counterclockwise) or right (clockwise).
6	Trailer Brake Control	Used to control brakes of trailer (when required).
7	DELETED	
8	START AID CONTROL BUTTON	Injects starting fluid into intake of engine to aid starting in cold weather.
9	WINCH Control Lever	Activates winch. Push up for IN, pull down for OUT.
10	EJECTOR Control Lever	Extends or retracts ejector. FWD for extend, BACK for retract.
11	APRON Control Lever	Raises or lowers apron. Push up for UP, pull down for DOWN.
12	Domelight Dimmer Switch	Adjusts brightness of domelight.
13	BILGE Pump Light	Indicates bilge pump is ON.
14	BILGE Pump Lever	Activates bilge pump to remove water from hull. Pull down for OFF, push up for ON.
15	Transmission Shift Lever	Selects transmission, forward (1-6), neutral, and reverse (1-2) ranges.
16	Warning Buzzer	Indicates low oil pressure, parking brake engaged, or unsprung/reverse mode.
17	Personnel Heater	Heats driver's compartment.
18	Bilge Pump Stop Lock	Locks bilge pump lever in the ON position. Prevents apron lever from moving in the ON position.
19	Ejector Stop Lock	Prevents ejector lever from moving.
20	Winch Stop Lock	Prevents winch lever from moving.

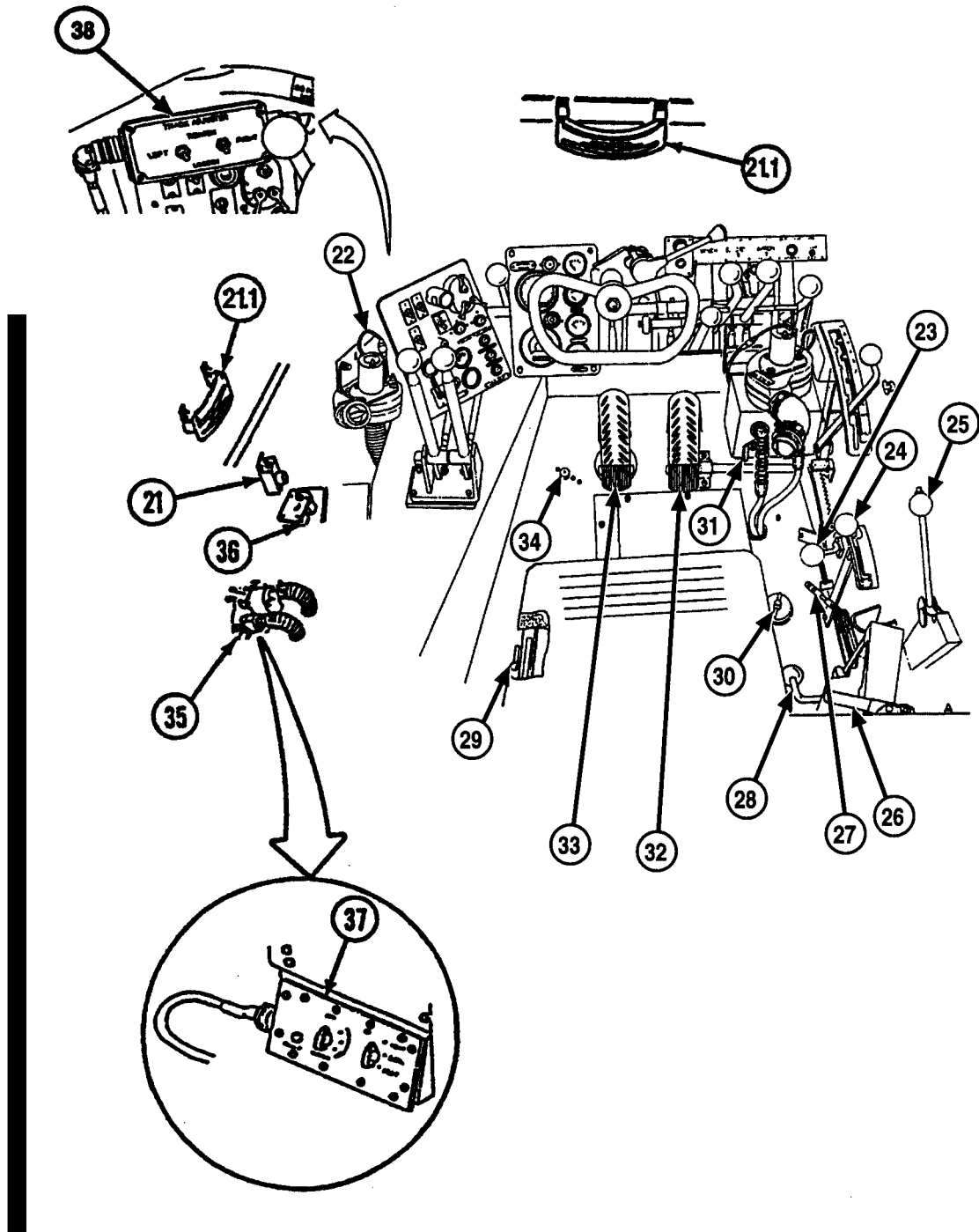

DRIVER'S CONTROLS AND INDICATORS - CONTINUED

Key	Control or Indicator	Function
21	ARMING FIRING UNIT	Controls arming and firing of smoke grenade launcher system.
21.1	Inclinometer	See page 2-8.1 (if equipped).
22	Ventilation Fan	Blows air through driver's compartment.
23	Hand Throttle	Used to keep engine at desired rpm for various work modes.
24	CB/GS Steer Selector Lever	Selects clutch brake (CB) or geared steer (GS) steering mode.
25	Winch Shift Lever	Shifts winch into high or low speed.
26	Hatch Cover Release	Used to release hatch cover.
27	Hand Brake Lever	Used to set brakes when parked.
28	Seat Vertical Adjusting Lever	Used to adjust height of driver's seat.
29	Seat Horizontal Adjusting Lever	Used to adjust forward and aft positions of driver's seat.
30	Hydraulic Oil Reservoir Filler and Dipstick	Used as optional check and fill point of oil in reservoir.
31	Heater Control Valve	Controls flow of coolant fluid through heater.
32	Accelerator Pedal	Controls flow of fuel to vary engine speed.
33	Brake Pedal	Activates steer unit brakes to stop vehicle.
34	Headlight Beam Selector Switch	Used to select high beam or low beam for service headlights.
35	NBC System Air Heater	Turns NBC system air heater ON and OFF, and adjusts temperature of air supply to mask. The NBC is removed if MCS unit is installed.
36	AIR PURIFIER SWITCH	Turns air purifier system ON and OFF. The air purifier switch is removed if MCS unit is installed.
37	MCS Control Box	Turns MCS ON and OFF, and has temperature control selector and NBC filter indicator light. The MCS control box is installed on MCS equipped vehicles only.
38	Semi-Automatic Track Adjuster Control Panel (NEW PRODUCTION)	Switches on the control panel allow for tightening and loosening of track.

DRIVER'S CONTROLS AND INDICATORS - CONTINUED

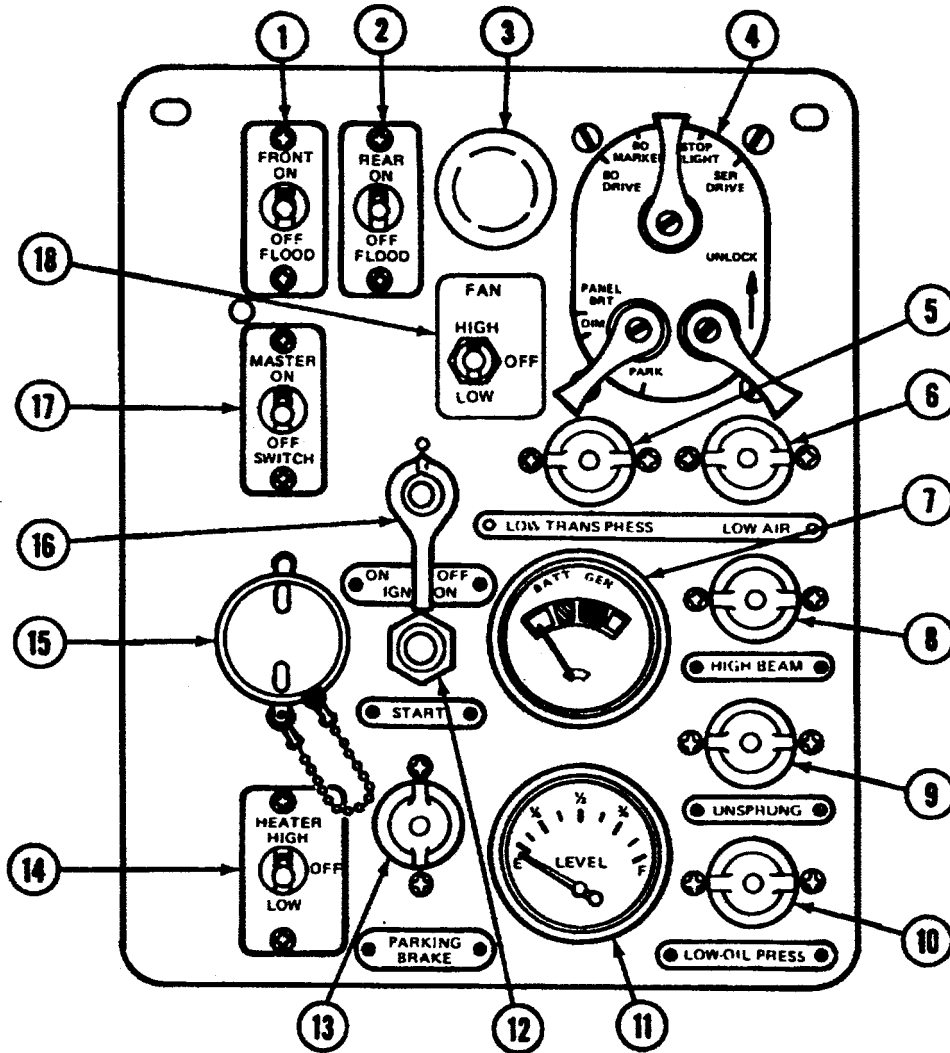

SWITCH PANEL

Key	Control or Indicator	Function
1	FLOODLIGHT Switch (FRONT)	Switches front floodlight ON or OFF.
2	FLOODLIGHT Switch (REAR)	Switches rear floodlight ON or OFF.
3	Panel Light	Lights switch panel. Is controlled by lever on light switch assembly.

DRIVER'S CONTROLS AND INDICATORS — CONTINUED

Key	Control or Indicator	Function
4	Light Switch Assembly	Controls driving and panel lights.
5	LOW TRANS PRESS Indicator Light	When lit, indicates low oil pressure in transmission, below 82 psi (565 kPa).
6	LOW AIR Indicator Light	When lit, indicates low air in brake system, below 60 psi (414 kPa).
7	BATT GEN Indicator	Indicates battery condition. Indicates generator voltage when engine is running.
8	HIGH BEAM Indicator Light	Indicates when service headlights are on high beam.
9	UNSPRUNG Indicator Light	When lit, indicates suspension is in UNSPRUNG and transmission is in reverse.
10	LOW-OIL PRESS Indicator Light	When lit, indicates low oil pressure in engine, below 7 psi (48 kPa).
11	Fuel LEVEL Indicator	Indicates the amount of fuel in the fuel tank.
12	START Switch	When pushed, activates starter motor which starts vehicle engine.
13	PARKING BRAKE Indicator Light	When lit, indicates parking brake is engaged.
14	HEATER Switch	Controls fan in driver's heater.
15	Utility Outlet	Provides 24-volt power from vehicle electrical system to operate auxiliary electrical equipment.
16	IGNITION ON/OFF Switch	Supplies power to start switch and operates fuel ON/OFF solenoid.
17	MASTER SWITCH	Controls all electrical power to the vehicle.
18	FAN Switch	Switches driver's compartment fan HIGH, LOW, or OFF.

DRIVER'S CONTROLS AND INDICATORS — CONTINUED

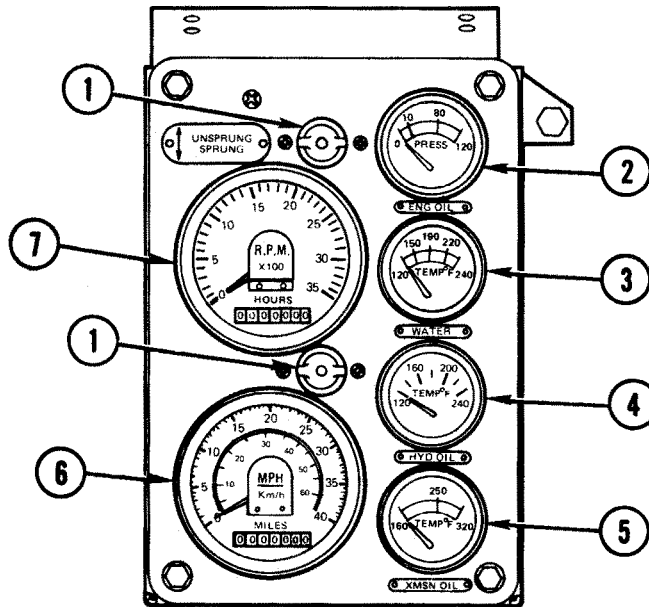

GAGE PANEL

Key	Control or Indicator	Function
1	Panel Light (s)	Lights gage panel. Is controlled by lever on light switch assembly (p 2-7).
2	ENG OIL PRESS Indicator	Indicates pressure of engine oil in pounds per square inch (psi). Normal operating range (green) is 10 to 80 psi (69 to 552 kPa).
3	WATER TEMP Indicator	Indicates temperature of engine coolant in degrees Fahrenheit. Normal operating range (green) is 150° to 190°F (66° to 88°C).
4	HYD OIL TEMP Indicator	Indicates temperature of hydraulic oil in degrees Fahrenheit. Not to exceed 240°F (116°C). During extensive dozing operations, normal operating range is 140° to 220°F (60° to 104°C).
5	XMSN OIL TEMP Indicator	Indicates temperature of oil in transmission in degrees Fahrenheit. Normal operating range (green) is 160° to 250°F (71° to 121°C).
6	Speedometer	Indicates vehicle speed in miles per hour (mph) or kilometers per hour (km/h). Also indicates total miles traveled.
7	Tachometer/Hourmeter	Indicates engine speed in revolutions per minute (rpm) and operating hours.

DRIVER'S CONTROLS AND INDICATORS - CONTINUED

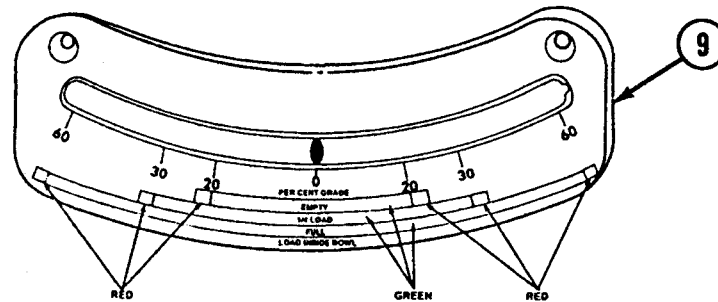
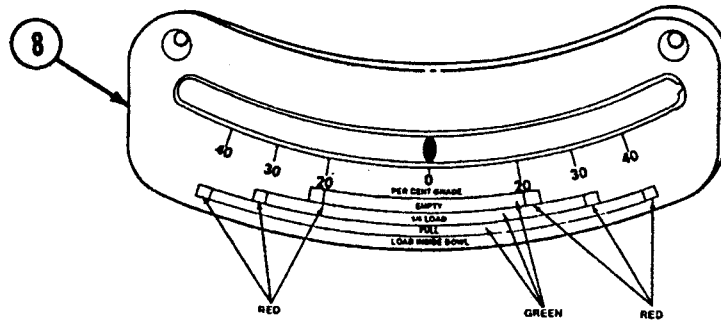

Key	Control or Indicator	Function
8	FRONT INCLINOMETER (SIDE TO SIDE 40 %)	Mounted over the steering wheel, the front inclinometer indicates vehicle side slope. Ranges are given for recommended side slope operations for specific vehicle conditions.
9	SIDE INCLINOMETER (FORE/AFT 60 %)	Mounted on the driver's compartment wall above and to the left of the suspension control levers, the side inclinometer indicates the grade the vehicle is climbing or descending. Ranges are given for recommended grades for specific vehicle conditions.

DRIVER'S CONTROLS AND INDICATORS - CONTINUED

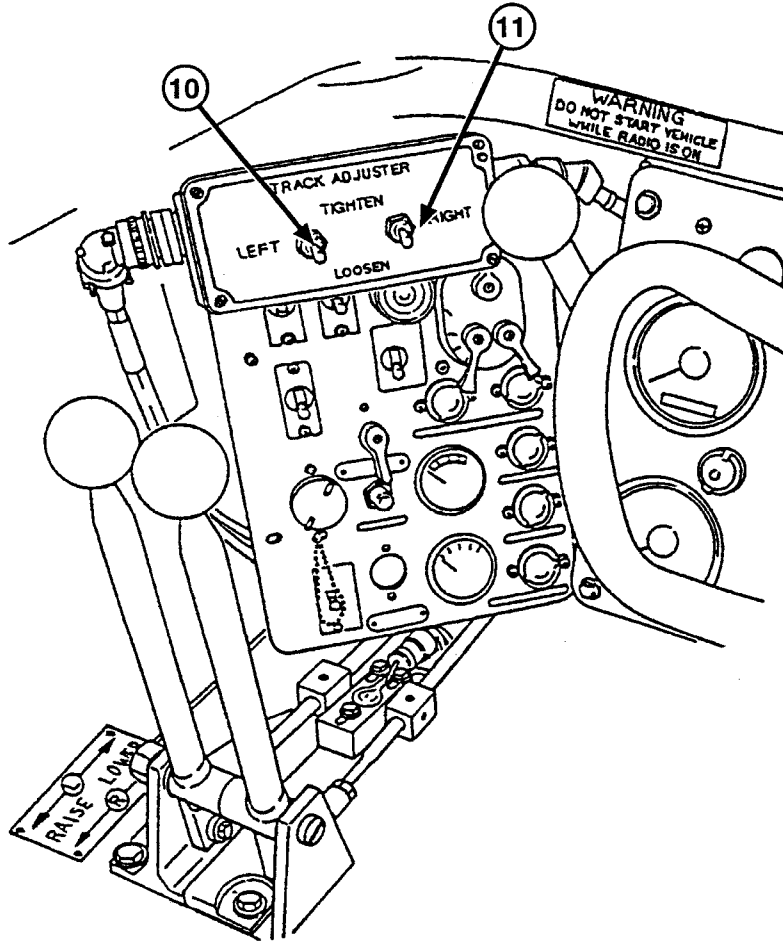

KEY	CONTROL OR INDICATOR	FUNCTION
10	Left Track Adjustment TIGHTEN/LOOSEN Switch (NEW PRODUCTION)	Mounted over switch panel, provides operator ability to manually adjust semi-automatic track adjusting cylinder on left side of vehicle.
11	Right Track Adjustment TIGHTEN/LOOSEN Switch (NEW PRODUCTION)	Mounted over switch panel, provides operator ability to manually adjust semi-automatic track adjusting cylinder on right side of vehicle.

Section II. PREVENTIVE MAINTENANCE CHECKS AND SERVICES (PMCS)

GENERAL

Every mission begins and ends with paperwork. There is not much of it, but you have to keep it up. The forms and records you fill out have several uses. They are a permanent record of the services, repairs, and modifications made on your vehicle. They are reports to unit maintenance and to your commander. They are also a checklist for you when you want to know what is wrong with the vehicle after its last use, and whether those faults have been fixed. For the information you need on forms and records, see DA Pam 738-750.

OPERATOR/CREW PREVENTIVE MAINTENANCE CHECKS AND SERVICES

- 1 Do your before (B) PREVENTIVE MAINTENANCE just before you operate the vehicle. Pay attention to the WARNINGS and CAUTIONS.
- 2 Do your during (D) PREVENTIVE MAINTENANCE while the equipment and/or its component systems are in operation. Pay attention to the WARNINGS and CAUTIONS.
- 3 Do your after (A) PREVENTIVE MAINTENANCE right after operating the vehicle.
- 4 Do your weekly (W) PREVENTIVE MAINTENANCE once a week.
- 5 Do your monthly (M) PREVENTIVE MAINTENANCE once a month.
- 6 If something does not work, troubleshoot it with the instructions in this manual or notify your supervisor.
- 7 Always do your PREVENTIVE MAINTENANCE in the same order so it gets to be a habit. Once you've had some practice, you'll spot anything wrong in a hurry.
- 8 When you do your PREVENTIVE MAINTENANCE, take along a rag or two.
- 9 While performing PMCS, observe warnings and cautions preceding those operations which could endanger your safety or result in damage to the equipment.

**OPERATOR/CREW PREVENTIVE MAINTENANCE CHECKS AND SERVICES
— CONTINUED**

WARNING

Drycleaning solvent is flammable and will not be used near an open flame. A fire extinguisher will be kept nearby when the solvent is used. Use only in well-ventilated places. Failure to comply may result in damage to equipment or injury to personnel.

- 10** If anything looks wrong and you can't fix it, write it on your DA Form 2404. The number column is the source for the numbers used on the TM Number Column on DA Form 2404. If you find something seriously wrong, report it to unit maintenance RIGHT NOW.
- a. **Keep it clean:** Dirt, grease, oil, and debris only get in the way and may cover up a serious problem. Clean as you work and as needed. Use drycleaning solvent (P-D-680) to clean metal surfaces. Use soap and water when you clean rubber or plastic materials.
 - b. **Bolts, nuts, and screws:** Check that they are not loose, missing, bent, or broken. You cannot try them all with a tool, of course, but look for chipped paint, bare metal, or rust around bolt heads. Tighten any that you find loose. Report other problems to unit maintenance.
 - c. **Welds:** Look for loose or chipped paint, rust, or gaps where parts are welded together. If you find a bad weld, report it to unit maintenance.
 - d. **Electric wires and connectors:** Look for cracked or broken insulation, bare wires, and loose or broken connectors. Tighten loose connections and make sure the wires are in good condition.
 - e. **Hoses and fluid lines:** Look for wear, damage, and leaks. Make sure clamps and fittings are tight. Wet spots show leaks. A strain around a fitting or connector can mean a leak. If a leak comes from a loose fitting or connector, tighten it. If something is broken or worn out, either correct it or report it to unit maintenance.

**OPERATOR/CREW PREVENTIVE MAINTENANCE CHECKS AND SERVICES
— CONTINUED**

- 11 It is necessary for you to know how fluid leaks affect the status of your equipment. The following are definitions of the types/classes of leakage you need to know to be able to determine the status of your equipment. Learn and be familiar with them and **REMEMBER** — When in doubt, notify your supervisor.

LEAKAGE DEFINITIONS FOR OPERATOR/CREW PMCS

Class I	Seepage of fluid (as indicated by wetness or discoloration) not great enough to form drops.
Class II	Leakage of fluid great enough to form drops, but not enough to cause drops to drip from the item being checked/inspected.
Class III	Leakage of fluid great enough to form drops that fall from the item being checked/inspected.

CAUTION

Equipment operation is allowable with minor leakages (Class I or II). Of course, consideration must be given to the fluid capacity in the item/system being checked/inspected. When operating with Class I or II leaks, continue to check fluid levels as required on your PMCS. Class III leaks should be reported to your supervisor or unit maintenance. Failure to comply will result in damage to equipment.

Table 2-1. Preventive Maintenance Checks and Services for M9 ACE

Item No.	Interval	Location	Crewmember Procedure	Not Mission Capable If:
		Item to Check/ Service		
			<p style="text-align: center;">WARNING</p> <p>Always Remember The CAUTIONS, WARNINGS, And NOTES Before Operating This Vehicle And Prior to PMCS.</p> <p style="text-align: center;">NOTE</p> <p>Perform your Before, After, and Weekly PMCS checks if:</p> <ul style="list-style-type: none"> a. You are the assigned driver but have not operated the vehicle since the last weekly inspection. b. You are operating the vehicle for the first time. c. See separate manuals for radios. 	

Table 2-1. Preventive Maintenance Checks and Services for M9 ACE – Continued

Item No.	Interval	Location	Crewmember Procedure	Not Mission Capable If:
		Item to Check/ Service		
1	Before	Vehicle Exterior	<p>a. Check exterior of vehicle for damage and missing items. Ensure all items are properly secured.</p> <p>b. Check wire and lead seal on external fire extinguisher handle.</p> <p>c. Check outside of vehicle for signs of fuel, coolant and oil leaks.</p> <p>d. Check underside for damage to hull and access covers.</p>	<p>b. Wire or lead seal on external fire suppression handle is missing or broken.</p> <p>c. Any Class III fuel, oil or coolant leak is found.</p> <p>d. Access covers cannot be installed or missing.</p>
2	Before	Hull Drain Valve	Check that hull drain valve is closed and securely seated against hull.	Deleted.

Table 2-1. Preventive Maintenance Checks and Services for M9 ACE – Continued

Item No.	Interval	Location	Crewmember Procedure	Not Mission Capable If:
		Item to Check/Service		
3	Before	Cooling System	<p style="text-align: center;">WARNING</p> <p>If engine has been recently operated, do not remove radiator cap to check coolant level. Cooling system is under pressure and escaping steam or coolant can cause burns.</p> <p style="text-align: center;">CAUTION</p> <p>Overheating, caused by lack of coolant, will cause engine damage.</p> <p>a. Check radiator coolant level. Look into radiator filler neck. If coolant level is below filler tube, add coolant into radiator filler neck to bring level to bottom of tube in filler opening.</p> <p>b. Check to see that chain is installed on cap.</p> <p style="text-align: center;">CAUTION</p> <p>Coolant other than the approved antifreeze (MIL-A-46153) added in an emergency should be drained and replaced with approved antifreeze at the earliest opportunity.</p>	a. Radiator cap unserviceable or missing.

Table 2-1. Preventive Maintenance Checks and Services for M9 ACE -- Continued

Item No.	Interval	Location	Crewmember Procedure	Not Mission Capable If:
		Item to Check/ Service		
4	Before	Hydraulic Pressure Gage	<p>NOTE</p> <p>Pressure reading may vary depending on ambient temperature.</p> <p>Open engine intake grilles and check hydraulic pressure gage. Needle should be between 1500-2000 psi (pre-charged).</p>	Pressure is not between 1500-2000 psi (pre-charged).
<div style="display: flex; justify-content: space-around; align-items: center;"> <div style="text-align: center;">  </div> <div style="text-align: center;">  <p>PRESSURE GAGE</p> </div> </div>				
5	Before	Driver's Hatch Cover	Check that driver's hatch cover opens and closes freely, and locks in both OPEN and CLOSED positions.	Driver's hatch cover will not lock in OPEN or CLOSED position.
6	Before	Vision Blocks	Inspect for scratches, cracks, chips, and/or discoloration which impairs vision/visability.	Over 50% of vision is blocked or obstructed.

Table 2-1. Preventive Maintenance Checks and Services for M9 ACE – Continued

Item No.	Interval	Location	<u>Crewmember</u> Procedure	Not Mission Capable If:
		Item to Check/Service		
7	Before	Fixed Fire Extinguisher	<p>a. Check fixed fire extinguisher pressure gage on both bottles. Needle should be in green zone.</p> <p>b. Check fixed fire extinguisher activating handle and valve for missing or damaged seals.</p> <p>c. Check fire extinguisher lines and nozzles for cracks and corrosion.</p>	<p>a. Any bottle not in green zone and/or any bottle missing.</p> <p>b. Broken or missing seal.</p> <p>c. Any line or nozzle damaged.</p>

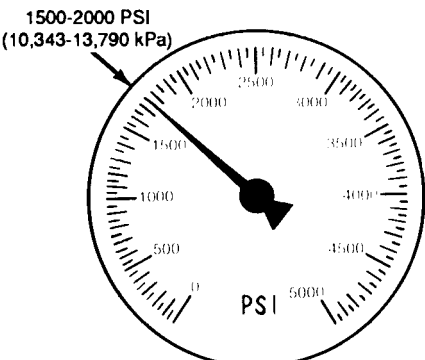
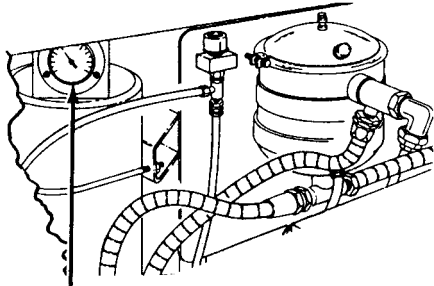
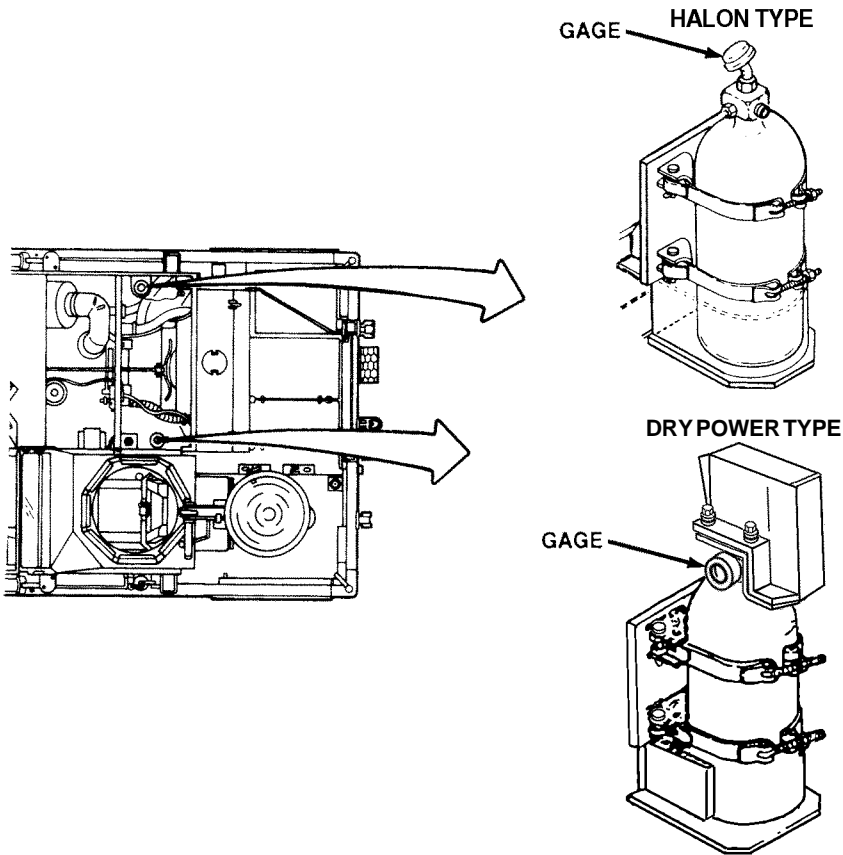

Table 2-1. Preventive Maintenance Checks and Services for M9 ACE – Continued

Item No.	Interval	Location	Crewmember Procedure	Not Mission Capable If:
		Item to Check/Service		
8	Before	Portable Fire Extinguisher	<p>a. Check for missing or damaged fire extinguisher.</p> <p>b. Deleted</p> <p>c. Check for damaged or missing seal.</p>	<p>a. Fire extinguisher missing or damaged.</p> <p>c. Seal broken or missing.</p>
				
9	Before	Hydraulic Pressure Gage	<p>Check hydraulic pressure gage with engine speed at 1500 rpm. Reading should not be below 2800 psi.</p>	<p>Pressure is below 2800 psi.</p>
				

Table 2-1. Preventive Maintenance Checks and Services for M9 ACE – Continued

Item No.	Interval	Location	Crewmember Procedure	Not Mission Capable If:
		Item to Check/Service		
10	Before	Driver's Instrument Panel Indicators and Buzzer	<p>NOTE</p> <ul style="list-style-type: none"> • Buzzer indicates low engine oil pressure, parking brake on, or unsprung/reverse mode. • When starting a cold engine, the engine oil pressure gage may register high oil pressure. As engine warms up, pressure will go down to normal. If not, turn engine off and report it to unit maintenance. <p>Check instrument panel gages and lights.</p> <p>a. Check LOW TRANS PRESS indicator light.</p>	a. LOW TRANS PRESS indicator light on.

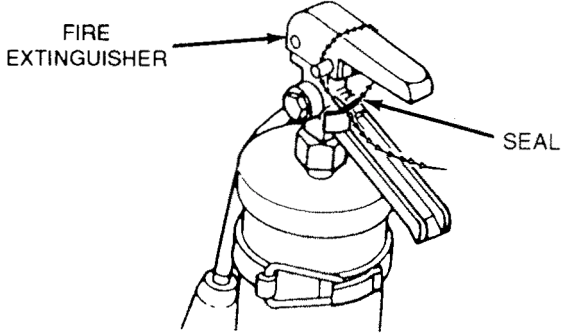
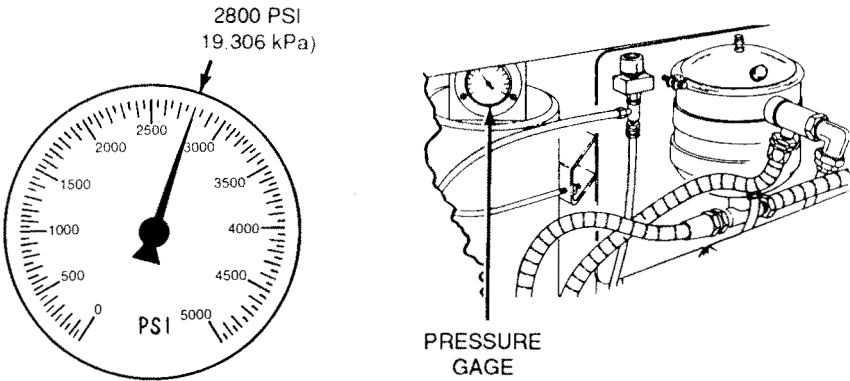
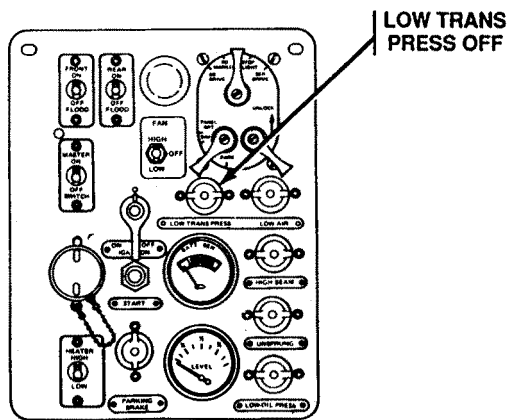

Table 2-1. Preventive Maintenance Checks and Services for M9 ACE – Continued

Item No.	Interval	Location	Crewmember Procedure	Not Mission Capable If:
		Item to Check/Service		
10	Before	Driver's Instrument Panel Indicators and Buzzer Continued	<p>b. Check XMSN OIL TEMP gage (160°F to 250°F).</p> <p>c. Check LOW OIL PRESS indicator light.</p> <p>d. Check ENG OIL PRESS gage (10 to 80 psi).</p> <p>e. Check WATER TEMP gage (150°F to 190°F).</p>	<p>b. XMSN OIL TEMP gage pointer is in red zone or fails to register.</p> <p>c. LOW OIL PRESS indicator light on.</p> <p>d. ENG OIL PRESS gage pointer is in red zone or fails to register.</p> <p>e. WATER TEMP gage pointer is in red zone or fails to register.</p>

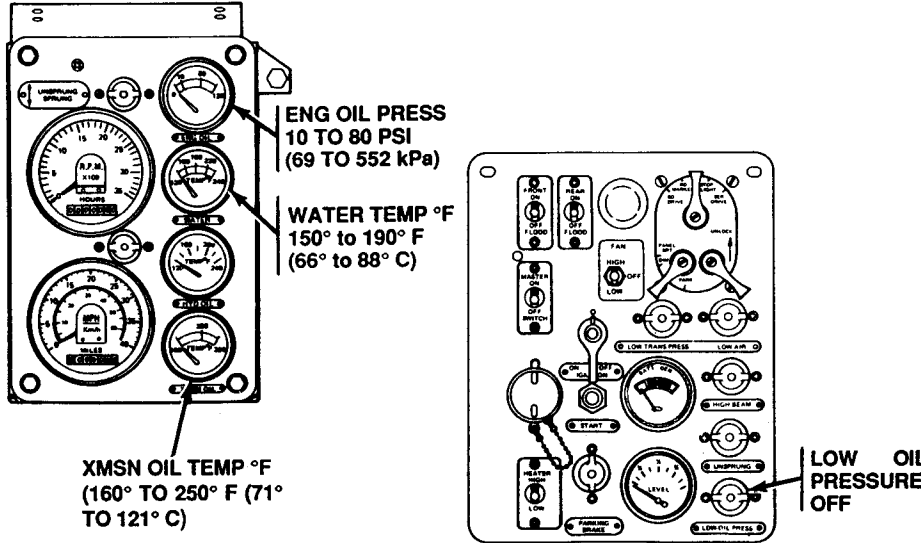

Table 2-1. Preventive Maintenance Checks and Services for M9 ACE – Continued

Item No.	Interval	Location	Crewmember Procedure	Not Mission Capable If:
		Item to Check/ Service		
10	Before	Driver's Instrument Panel Indicators and Buzzer Continued	<p>g. Check BATT GEN gage.</p> <p>h. Check HYD OIL TEMP gage.</p> <p>i. Check LOW AIR indicator light.</p> <p>j. Check TACHOMETER idle speed (750-850 RPM).</p> <p>k. If MCS unit is to be used, check the following modes (p 2-86.2).</p>	<p>g. BATT GEN gage pointer is in red zone or fails to register.</p> <p>h. HYD OIL TEMP gage pointer is above 240°F or fails to register.</p> <p>i. LOW AIR indicator light on.</p>

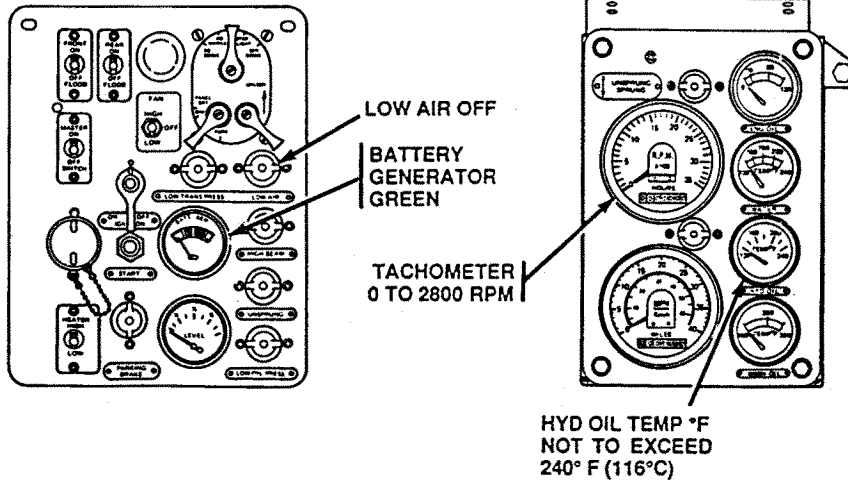

Table 2-1. Preventive Maintenance Checks and Services for M9 ACE – Continued

Item No.	Interval	Location	Crewmember Procedure	Not Mission Capable If:
		Item to Check/ Service		
11	Before	Carrier Communications Equipment Radio	Check radio equipment for proper operation. Perform PMCS IAW TM 11-5820-498-12 and/or TM 11-5820-401-10-2, as needed. See TM 11-5965-286-14 for headset microphone.	Fault listed in "Not Fully Mission Capable If" column of radio TM. Will not transmit or receive.
12	Before	CB/GS Steer Selector	Place CB/GS steer selector in CB. Operate transmission shift selector from neutral to 6th gear and observe that CB/GS steer selector shifts into GS when transmission shift selector hits 5th gear. Move transmission shift selector from 6th to R2 position and observe that CB/GS steer selector shifts into CB position.	CB/GS steer selector does not move into appropriate gear when transmission shift selector is placed in 6th or R2 position.
13	Before	Parking Brake	<p>NOTE</p> <p>Parking brake must be set with engine running and foot brake applied.</p> <p>a. Check parking brake.</p> <p>b. Push down and hold brake pedal."</p> <p>c. Pull parking brake handle up and over center.</p> <p>d. Release foot pressure, shift transmission into 5th gear and apply power (about 100 rpm over idle) to see if parking brake will hold.</p>	d. Parking brake is defective, inoperable, out of adjustment, or will not hold vehicle.

Table 2-1. Preventive Maintenance Checks and Services for M9 ACE – Continued

Item No.	Interval	Location	Crewmember Procedure	Not Mission Capable If:
		Item to Check/Service		
14	During	Steering	<p>WARNING</p> <p>Ensure brakes are applied when checking transmission shift selector. Failure to comply may result in severe injury to personnel.</p> <p>a. Operate vehicle in geared steer (GS) and clutch brake (CB) and note any deficiencies.</p> <p>b. Check transmission shift operation.</p>	<p>a. Erratic movement.</p> <p>b. Transmission shift selector binds when moved. Transmission does not fully engage when shift selector is put in gear.</p>

Table 2-1. Preventive Maintenance Checks and Services for M9 ACE - Continued

Item No.	Interval	Location	Crewmember Procedure	Not Mission Capable if:
		Item to Check/ Service		
15	During	High-Pressure Filters	<p>WARNING</p> <p>Ensure brakes are applied when checking high-pressure filters. Failure to comply may result in severe injury to personnel.</p> <p>Move ejector forward. Check indicator on high-pressure filters.</p>  <p>INDICATOR</p>	Indicator is out.
16	During	Driver's Heater	<p>NOTE</p> <p>Perform this check only if operating in cold weather or if heater operation is anticipated.</p> <ol style="list-style-type: none"> Check coolant flow control valve for smooth operation and leaks. Check blower control for proper operation in high and low setting. Listen for unusual noise from heater during operation. 	

Table 2-1. Preventive Maintenance Checks and Services for M9 ACE – Continued

Item No.	Interval	Location	Crewmember Procedure	Not Mission Capable If:
		Item to Check/Service		
17	After	Hydraulic Oil Level	<p>WARNING</p> <p>Do not operate ejector when personnel are in bowl. Do not stand or work in bowl area unless ejector lock is engaged. Severe injury to personnel may result.</p> <p>NOTE</p> <p>Hydraulic pressure must be relieved for accurate reading of hydraulic oil level.</p> <p>Check oil level on gage with apron down and ejector retracted. Check oil level; maintain with full mark.</p>	

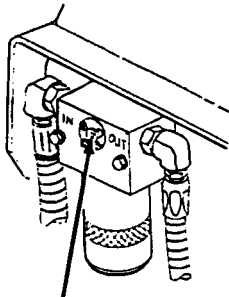
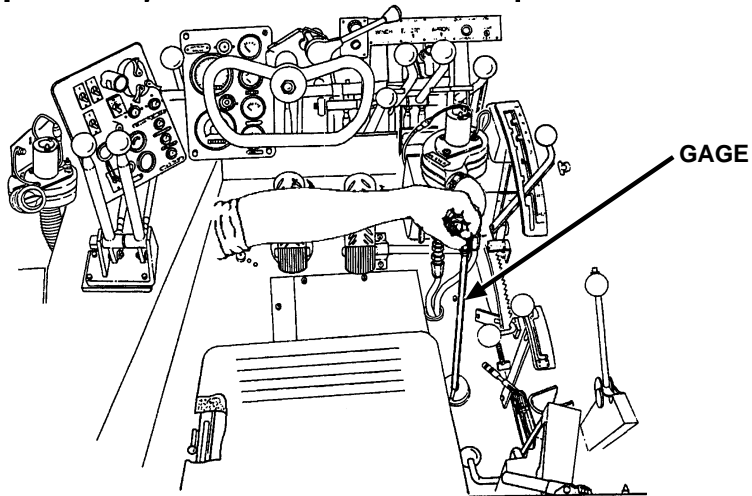

Table 2-1. Preventive Maintenance Checks and Services for M9 ACE - Continued

Item No.	Interval	Location	Crewmember Procedure	Not Mission Capable if:
		Item to Check/Service		
18	After	Driver's Seat	Check driver's seat adjustment for proper operation.	
19	After	Transmission, Steer Unit, Transfer Case, and Final Drive Oil Levels	<p>Put vehicle in neutral and engage parking brake.</p> <p>Lift out and remove the three rear platform panels.</p> <p>NOTE</p> <p>Steer unit check must be made on level ground with the engine running.</p> <p>After engine has idled 3 to 5 minutes, remove steer unit dipstick and check oil level. Oil should be in operation range. Add oil if necessary, but do not overfill.</p> <p>NOTE</p> <p>Move ejector forward and lock control lever with lock. SHUT VEHICLE OFF.</p> <p>NOTE</p> <p>Check final drive level when oil is hot.</p> <p>Remove both final drive gauges and check oil level. Oil should be within flat area on gauge. Add oil as necessary, but do not overfill.</p> 	

Table 2-1. Preventive Maintenance Checks and Services for M9 ACE - Continued

Item No.	Interval	Location	Crewmember Procedure	Not Mission Capable if:
		Item to Check/Service		
19.1	After	Final Drive Flanges	Check both flanges for cracks.	Flange is cracked.
20	After	High Pressure Filters	<p style="text-align: center;">WARNING</p> <p>Ensure brakes are applied when checking high-pressure filters. Failure to comply may result in severe injury to personnel.</p> <p>Check indicator on high-pressure filters.</p>  <p style="text-align: center;">INDICATOR</p>	Indicator is out.
21	After	Exterior and Interior Vehicle Lights	Check that headlights, taillights, blackout lights, floodlights, and dome light operate correctly and are not damaged.	
22	After	Suspension System	<p>Start checks at rear side of vehicle.</p> <p>a. Inspect sprocket teeth for damage and wear.</p>  <p style="text-align: center;">WEAR INDICATOR</p>	<p>a. Two teeth broken on the same sprocket.</p> <p>Same tooth broken on both inner and outer sprocket on same side (left or right).</p> <p>Two screws securing inner sprocket to hub missing or broken.</p> <p>Any outer carrier to hub nut missing or unserviceable.</p> <p>Sprocket tooth worn into wear indicator.</p>

Table 2-1. Preventive Maintenance Checks and Services for M9 ACE – Continued

Item No.	Interval	Location	Crewmember Procedure	Not Mission Capable If:
		Item to Check/ Service		
22	After	Suspension System Continued	<p>b. Check roadwheels for loss of rubber, pitting, chunking, and separation of rubber from metal.</p> <p>c. Check for missing and damaged roadwheels.</p> <p>d. Inspect for missing track retainers. Inspect retainers for rips, cracks, and retainers that bend outward more than 3 inches (7.61 cm) at edges. Check for loose, missing, bent, and broken mounting hardware.</p> <p>e. Check inner wear plates and wear bars on hull for rips, cracks and gouges; missing and peeling more than 1/8 inch at edges, and for hull exposure. Check for loose, missing, bent, and broken hardware.</p> <p style="text-align: center;">NOTE</p> <p>If plate is worn flush with screw head have unit maintenance replace wear plate.</p>	<p>b. Separation of 1-inch of rubber contact from metal surface around 75% of roadwheel and/or chunking that exposes metal extending 3 x 4 inches on wheel surface exists.</p> <p>c. Any missing, dented, warped, or damaged roadwheels or any mounting hole elongated.</p> <p>d. Track retainer missing or bent outward more than 3 inches.</p> <p>e. Track wear plate missing or peeling more than 1/8 inch at edges.</p>

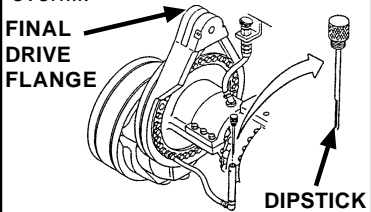
Table 2-1. Preventive Maintenance Checks and Services for M9 ACE - Continued

Item No.	Interval	Location	<u>Crewmember</u> Procedure	Not Mission Capable If:
		Item to Check/Service		
22	After	Suspension System Continued	<p>f. Inspect track pads.</p> <p>Check for loose or missing pads, pads worn even with track shoes and that one-half of contact surface of pad is chunked out.</p> <p style="text-align: center;">NOTE</p> <p>Off-centered track pin nuts indicate worn bushings.</p> <p>g. Check for off-center and missing track pin nuts, cracked, bent and broken center guides, broken track shoes.</p> <p>h. Check for broken and bent roadwheel arms.</p> <p>i. Check for missing, loose, or damaged road wheel lug nuts and mounting studs.</p>	<p>g. Any cracked, bent or broken track shoes. Three or more broken center guides in a row. Any track shoe with worn bushing, protruding track pin or missing track pin nut. Any bushing deemed unserviceable.</p> <p>h. One or more broken or bent roadwheel arms.</p> <p>i. Three or more road wheel lug nuts or mounting studs are missing, loose, or damaged.</p>

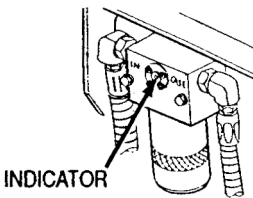
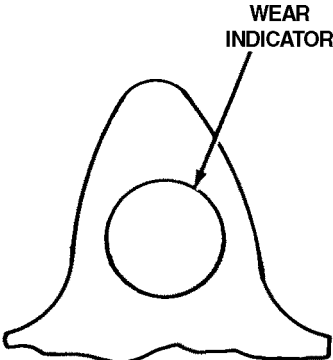
Table 2-1. Preventive Maintenance Checks and Services for M9 ACE- Continued

Item No.	Interval	Location	Crewmember Procedure	Not Mission Capable If:
		Item to Check/ Service		
23	After	Hubs	<p style="text-align: center;">WARNING</p> <p>Hot hubs can burn you. Lightly touch hubs to see if they are hot.</p> <p>a. Check all hubs for any large differences in temperature. Pass hands near hubs.</p> <p>b. Check hub lubrication fittings and bleed valves for leaks.</p> <p>c. Check for worn mounting holes and loose fasteners by looking around nuts, bolts, and screws.</p>	<p>a. Any hub is over-heated.</p> <p>b. Hub lubrication fittings or bleed valves leak.</p> <p>c. Any stud or nut missing or broken.</p>
23.1	After	Track Tension/ Adjuster (OLD PRODUCTION)	<p>a. Check track tension. Adjust track tension as needed (page 3-26 and 3-27).</p> <p>b. Check track adjuster lubrication fitting and bleed valves for leaks.</p>	<p>a. Track is loose or cannot be adjusted. Adjuster bent, broken, or damaged.</p> <p>b. Track adjuster lubrication fitting or bleed valve leaks.</p>
23.2	After	Track/ Tension Adjuster Hydraulic (NEW PRODUCTION)	<p>a. Check track tension. Adjust track tension as needed (page 3-27.1).</p>	<p>a. Track is loose or cannot be adjusted. Adjusting cylinder bent, broken, or damaged.</p> <p>b. Manual or semi-automatic track adjustment inoperative</p> <p>c. Track adjusting cylinder(s) or track adjuster manifold assembly. Class III leak.</p>

Table 2-1. Preventive Maintenance Checks and Services for M9 ACE – Continued

Item No.	Interval	Location	Crewmember Procedure	Not Mission Capable If:
		Item to Check/Service		
23.3	After	Rotary Actuators	Check rotary actuators outside the hull for loose mounting screws, oil leaks, damage, and cracks.	Actuators (without mounting rings), any broken, stripped, missing screws, or Class III leak. Actuators (with mounting rings), more than two broken, stripped, missing screws, or Class III leak.
24	After	Fuel System	Inspect fuel tank for leaks and loose, missing, and broken hardware.	Class III leak.
25	After	Fuel Filler Cap	Remove filler cap and check filter screen for damage and debris.	

Item No.	Interval	Location	Crewmember Procedure	Not Mission Capable if:
		Item to Check/Service		
26	After	Engine Compartment	Open engine access covers. Check engine compartment hoses, clamps, and fittings for	Any fluid Class III leak is found
27	After	Engine Oil	Check the engine oil level gage for proper oil level (should be between the L (Low) and H (High) marks). Add oil, if necessary, but do not overfill.	

GAGE

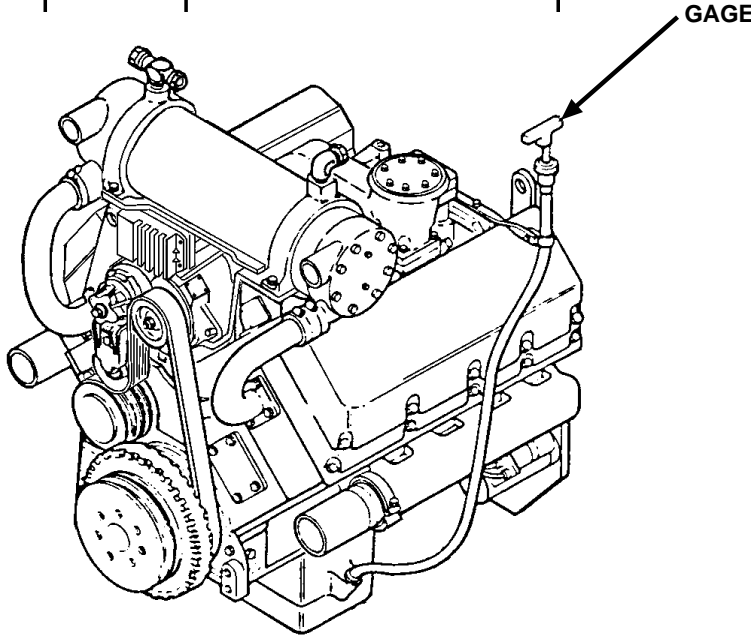

Table 2-1. Preventive Maintenance Checks and Services for M9 ACE – Continued

Item No.	Interval	Location	Crewmember Procedure	Not Mission Capable If:
		Item to Check/Service		
28	After	Fan Tensioner	Check to be sure fan tensioner indicator is in normal range.	Fan tensioner is inoperative.
 <p>The diagram illustrates the fan tensioner mechanism. On the left, a cutaway view shows the fan assembly with a belt and a tensioner. An arrow points from the tensioner to a detailed view on the right. This detailed view shows a spring-loaded tensioner with a vertical rod and a scale. The scale has markings for 'HIGH', 'NORMAL RANGE', and 'LOW'. A line points from the 'NORMAL RANGE' label to the corresponding position on the scale.</p>				
29	After	Drivebelts	Check for missing, broken, cracked, and frayed drivebelts. Check generator and fan belts 1/2-inch to 5/8-inch deflection. Check for looseness, dry rot, excessive fraying, and cracks.	Any drivebelt is missing or broken. Belt fiber has more than one crack (1/8-inch in depth or 50% of belt thickness) or has frays more than 2 inches long.
30	After	Fan Assembly	a. Inspect axial fan assembly for cracks, missing fan blades, loose and missing hardware. b. Check all pulleys for bends, cracks, and damage.	a. Cracks, missing blades, loose or missing hardware. b. Any pulley cracked or missing.
31	After	Engine	Check engine and engine oil cooler for leaks.	Class III leak.
32	After	Exhaust System	Inspect exhaust clamps for loose and missing screws. Close access covers.	

Table 2-1. Preventive Maintenance Checks and Services for M9 ACE – Continued

Item No.	Interval	Location	<u>Crewmember</u> Procedure	Not Mission Capable If:
		Item to Check/Service		
33	After	Intake Grilles	<p>Open intake grilles.</p> <p>a. Check for any restrictions to airflow, loose and missing mounting hardware.</p> <p>b. Check air cleaner indicator. If in red area, service/replace element.</p> <p>c. Check hydraulic components for damage and leaks.</p> <p>Close intake grilles.</p>	<p>b. Air indicator in red or broken.</p> <p>c. Class III leaks.</p>
34	After	Batteries	<p style="text-align: center;">WARNING</p> <ul style="list-style-type: none"> ● Don't smoke, have open flames, or make sparks around the batteries, especially if the caps are off. Batteries can explode and cause injury or death. ● Remove all jewelry such as rings, dog tags, bracelets, etc. If jewelry contacts battery terminal, a direct short will result causing instant heating of tools, damage to equipment, and severe injury to personnel. <p>a. Check batteries for damaged casing, terminal posts, and security of mounting. In hot weather check more often.</p>	<p>a. One or more batteries missing, un-serviceable, leaking, terminals or cables are loose, corroded or holddowns are not secure.</p>

Table 2-1. Preventive Maintenance Checks and Services for M9 ACE – Continued

Item No.	Interval	Location	Crewmember Procedure	Not Mission Capable If:
		Item to Check/Service		
34	After	Batteries Continued	<p>b. Check electrolyte. It should be filled to the level/split ring. If fluid is gassing (boiling), notify organizational mechanic. If fluid is low, fill with distilled water to the level ring.</p> <p>c. Check battery box for corrosion.</p>	
35	After	Hull Compartment	<p>a. Check all lines, hoses, and fittings for looseness and leaks.</p> <p>b. Deleted</p> <p>c. Open fuel drain valve and drain accumulated water and debris into a suitable container through hose at rear of vehicle. Check for water.</p>	a. Class III leaks.

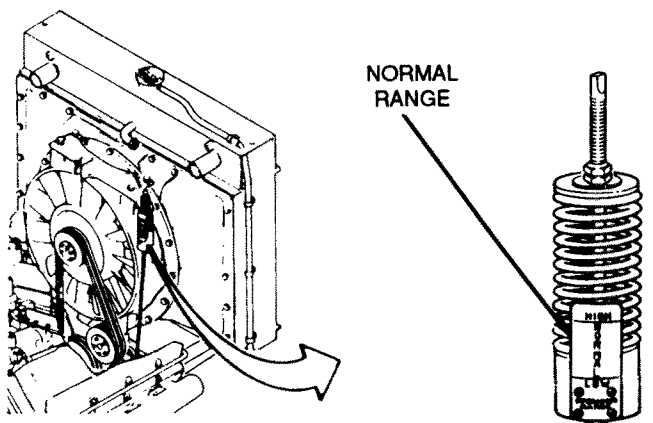
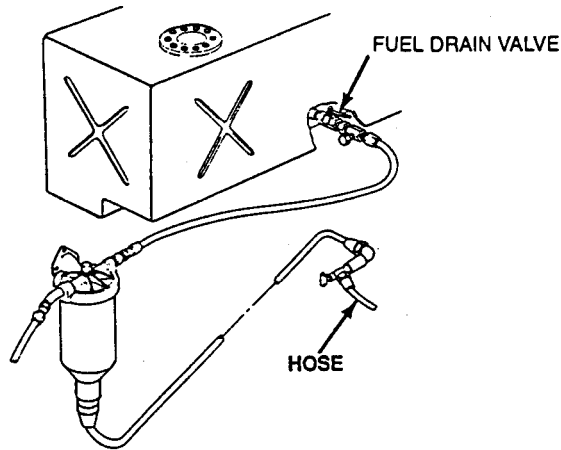

Table 2-1. Preventive Maintenance Checks and Services for M9 ACE – Continued

Item No.	Interval	Location	<u>Crewmember</u> Procedure	Not Mission Capable If:
		Item to Check/Service		
36	After	Transmission/Transfer Case	Check transmission assembly for cracks, leaks, and warps in hoses, lines, and fittings.	Class III leaks.
37	After	Apron Cylinders	Check cylinders and lines for leakage and mounting hardware.	Class III leaks. Any mounting hardware missing or broken.
38	After	Hydraulic Valve Bank	Check valve bank control linkage, filters, and hoses for damage, oil leaks, loose and missing mounting hardware.	Class III leaks or any damage that will keep hydraulics from working.

Table 2-1. Preventive Maintenance Checks and Services for M9 ACE – Continued

Item No.	Interval	Location	<u>Crewmember</u> Procedure	Not Mission Capable If:
		Item to Check/Service		
39	After	Ejector Assembly	<p>a. Check ejector guides, rollers, and mounting brackets for presence of cracks, breaks, bent roller mounting brackets, wear, and binding of ejector with walls or bottom of bowl.</p> <p>b. Check cylinder and lines for leaks.</p>	<p>a. Ejector scraping or binding on bottom or sides of bowl.</p> <p>b. Class III leak.</p>
40	After	Air Reservoir	Press drain valve at rear of vehicle, and drain condensation from reservoir.	Any air leak.

Table 2-1. Preventive Maintenance Checks and Services for M9 ACE – Continued

Item No.	Interval	Location	Crewmember Procedure	Not Mission Capable If:
		Item to Check/ Service		
41	Weekly	NBC System/ MCS if equipped	<p>a. Functionally check the NBC filtration system. Check for presence and proper operation of spring clip. Check for presence of hose, heater, and caps, and any damage to hose, heater and caps that may impair proper operation of NBC filtration system.</p> <p>b. Check that communication is possible while wearing NBC mask.</p> <p>c. If MCS equipped, check MCS control panel for proper operation in all temperature modes.</p> <p>d. Press test light to verify that test lamp is operational.</p> <p>e. If test light remains illuminated after being released, filter installation is incorrect. Notify unit maintenance.</p> <p>f. Check hoses and cage connector for damage or missing components.</p>	
42	Weekly	Scraper and Dozer Cutting Edges, Side Cutting Edges and End Bits	Check for damage and wear. Allowable wear limits on cutting edges are approximately 1/4 inch (6.4 mm) from mold board.	Exceeds allowable limits of 1/4 inch from mold board.
42.1	Weekly	Vent Fan Filter	Check element for any restrictions to air flow. Remove restrictions.	

Table 2-1. Preventive Maintenance Checks and Services for M9 ACE – Continued

Item No.	Interval	Location	Crewmember Procedure	Not Mission Capable If:
		Item to Check/Service		
			NOTE	
43	Weekly	Bilge Pump	<p>Although the Bilge Pump is considered Not Mission Essential and will no longer be supported with spare and repair parts, this manual contains operational procedures For Your Information Only. Notify Unit maintenance if the bilge pump no longer operates.</p> <p>a. Check bilge pump weekly and before any water operations.</p> <p>b. Feel bilge pump outlet for a stream of water if there is water in the carrier, or feel for a stream of air if water is absent.</p> <p>c. Check bilge pump intake screens for clogging. Clear screen of all trapped debris.</p>	b. Deleted.
44	Weekly	Winch	Inspect winch and wire rope for damage, hydraulic leaks, loose mounting hardware, and one or more cable strands kinked or broken.	Class III leak.

Section III. OPERATION UNDER USUAL CONDITIONS

ASSEMBLY AND PREPARATION FOR USE

Before operating a new or reconditioned vehicle, make sure unit maintenance services the vehicle in accordance with the instructions in TM 5-2350-262-20-1.

INITIAL ADJUSTMENT AND DAILY CHECKS

Performing the Preventive Maintenance Checks and Services (PMCS) on pages 2-12 through 2-31 before, during, and after operation ensures that all adjustments and daily checks required for effective vehicle operation will be completed.

OPERATING PROCEDURES

Become familiar with all the controls, instruments, and procedures before attempting to operate the vehicle (p 2-32 through 2-123).

WARNING

- Do not drive too fast over rough terrain; the dozer blade, ripper blade, or scraper can dig in, causing the vehicle to stop suddenly or to pitch. Failure to comply may result in damage to equipment or injury to operator.
- Operators are reminded to observe basic safe driving techniques/skills when operating the vehicle. Vehicle speed must be reduced consistent with weather and road terrain conditions. Failure to use basic safe driving techniques/skills may result in damage to equipment, injury to personnel, or death.
- Due to high intensity noise, double hearing protection is required when operating the vehicle. Failure to comply may result in injury to personnel.
- Allow the vehicle to coast to a halt if a track is thrown. Do not apply the brake while the vehicle is moving. Operator may lose control and injury to personnel or death may result.

CAUTION

- Never leave the vehicle unattended while the engine is running.
- This vehicle DOES NOT have an automatic transmission. It must be shifted manually.

Instructions and procedures required to operate the vehicle under normal conditions are on the following pages. Special instructions and procedures for operating under unusual conditions are in Section IV (p 2-95).

DELETED

HATCH COVER OPERATION

WARNING

Keep all parts of body from between hatch cover and hatch while opening or closing hatch cover. Hatch cannot be closed without standing. Ensure that inner handle is not stuck in open or upward position. Hatch cover detent locks will not engage unless inner handle is in closed or downward position. Failure to comply may result in severe injury to personnel.

TO OPEN HATCH COVER:

- 1 Turn handle (1) clockwise to unlock hatch cover (2). Open until reaching first detent lock (15 degrees).
- 2 Lift handle (3) (inside) or depress handle (4) (outside) to release hatch cover (2) from first detent lock (15 degrees).

CAUTION

Ensure hatch cover (when open) is in positive detent (180 degrees) during operations or equipment damage/ failure may result.

Note

Hatch cover is in positive open/locked position when holddown latch is over center of hatch cover arm notch, but not in contact with arm notch.

- 3 Release handle(s) and rotate cover towards open (180 degrees) position and push cover firmly into full open (second) detent lock (180 degrees). Cover should now be in open/locked position.

TO CLOSE HATCH COVER:

- 1 Depress handle (4) (outside), or lift handle (3) (inside), and push handle of holddown latch (5) outboard to release hatch cover (2). Cover will pop up about 30 degrees.
- 2 Lift hatch cover (2) toward closed position. It will reach a detent at 15 degrees.
- 3 To pass detent, lift handle (3) (inside) or depress handle (4) (outside) and close hatch fully with handle (1).

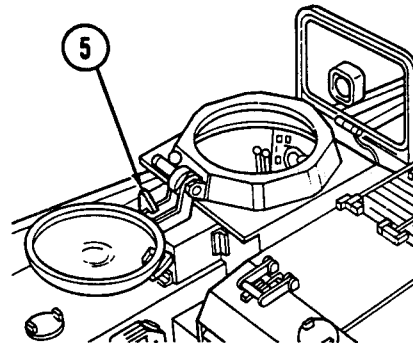
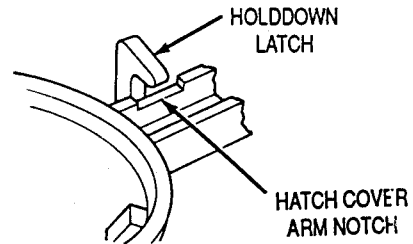
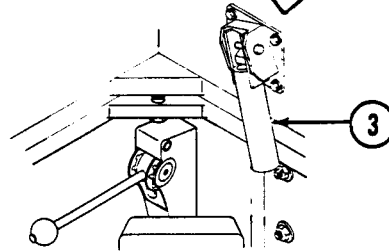
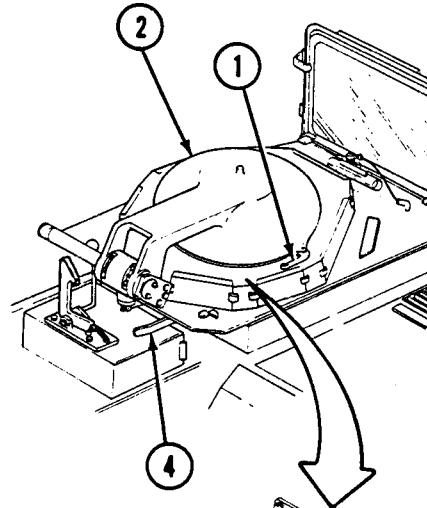

PRE-STARTING INSTRUCTIONS

- 1 Perform all the "Before" operation PMCS beginning on page 2-12.

WARNING

Make sure all body parts are clear from beneath driver's seat when making adjustments to seat. Failure to comply may result in injury to personnel.

- 2 Adjust the driver's seat:
 - Fasten seatbelt.
 - To adjust seat height, use body weight to hold seat and pull out (forward) on vertical adjust lever (1).
 - To adjust seat forward or backward, pull out (to right) horizontal adjust lever (2) and move seat to a comfortable position.

CAUTION

Ensure hatch cover (when open) is in positive detent (180 degrees) during operations or equipment damage/ failure may result.

Note

Hatch cover is in positive open/locked position when holddown latch is over center of hatch cover arm notch, but not in contact with arm notch.

- 3 Make sure hatch cover (3) is stowed and holddown latch (4) is engaged.

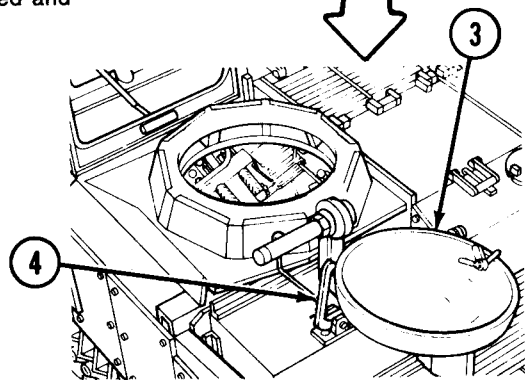
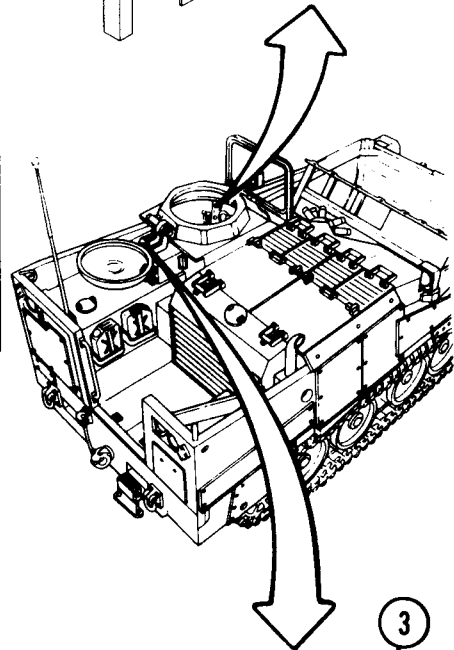
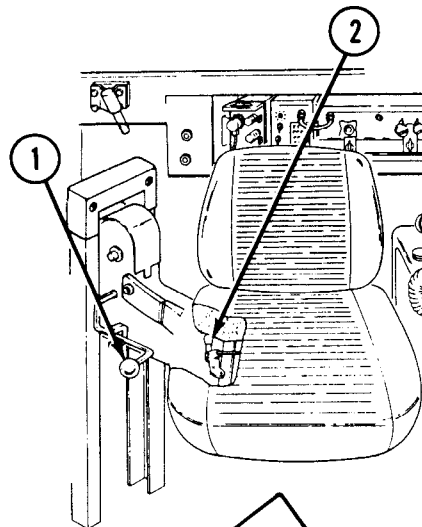

PRE-STARTING INSTRUCTIONS — CONTINUED

4 Make sure the following switches are set to OFF:

- FRONT FLOOD (1)
- REAR FLOOD (2)
- Light switch assembly (3)
- HEATER (4)
- IGNITION (5)
- MASTER (6)
- FAN (7)

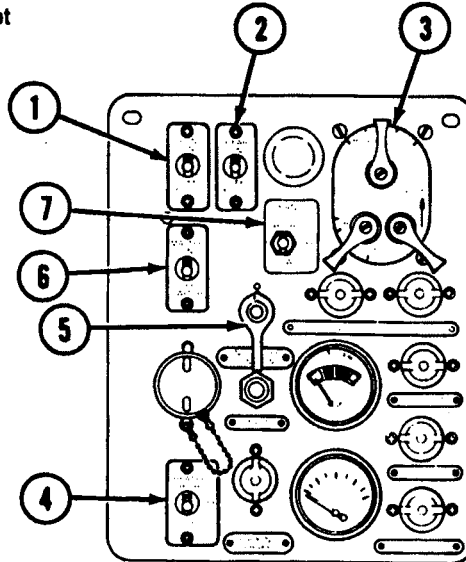

5 Check that hand throttle (8) is all the way to the rear.

6 Place transmission shift lever (9) in N (neutral) position.

7 Make sure the following auxiliary equipment is set to OFF:

- Radio
- Smoke grenade launcher
- NBC system

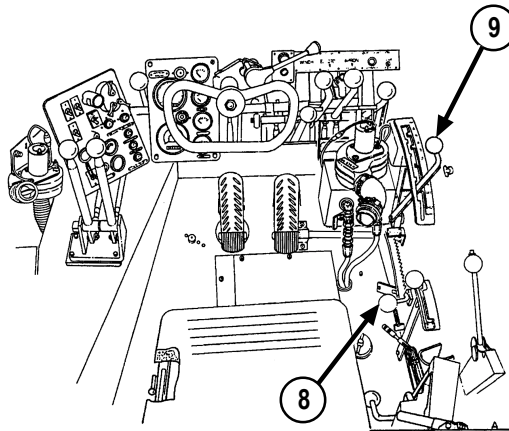

STARTING THE ENGINE

- 1 Set MASTER SWITCH (1) and IGNITION switch (2) to ON.
- 2 Make sure the warning buzzer sounds and the following lights illuminate:
 - LOW TRANS PRESS (3)
 - LOW AIR (4)
 - LOW-OIL PRESS (5)
 - PARKING BRAKE (6)

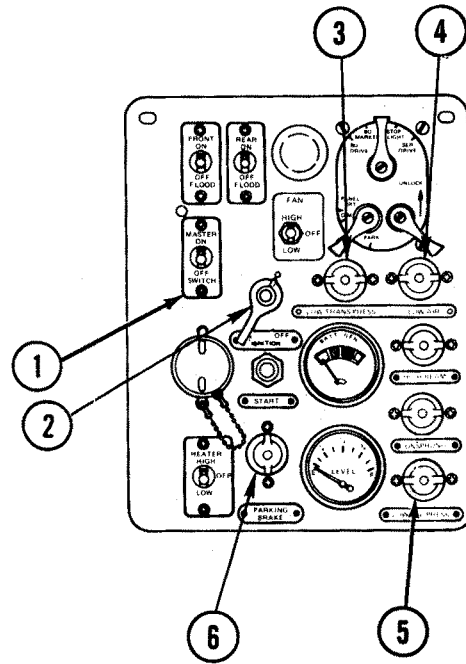

STARTING THE ENGINE — CONTINUED

WARNING

Due to high intensity noise, double hearing protection is required when operating the vehicle. Failure to comply may result in injury to personnel.

CAUTION

Do not operate starter continuously for more than 20 seconds. Let starter cool for 1 to 2 minutes before pressing START switch again. Failure to comply may result in damage to equipment.

- 3 Press START switch (1) and hold until engine starts. Engine oil pressure gage (2) should show about 5 psi (34 kPa) (move slightly above the 0 indication) within 3 to 10 seconds. If engine fails to start, or oil pressure falls to reach normal range of 10 to 80 psi (69 to 552 kPa) after 1 to 2 minutes, place IGNITION switch (3) and MASTER SWITCH (4) to OFF, and refer to engine troubleshooting procedures (p 3-2).
- 4 Move hand throttle (5) forward until engine speed is about 800 rpm, as indicated on tachometer (6). Perform instrument panel checkout procedures (p 2-39) at this time.

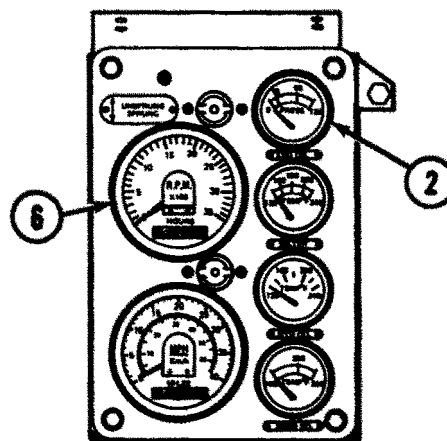
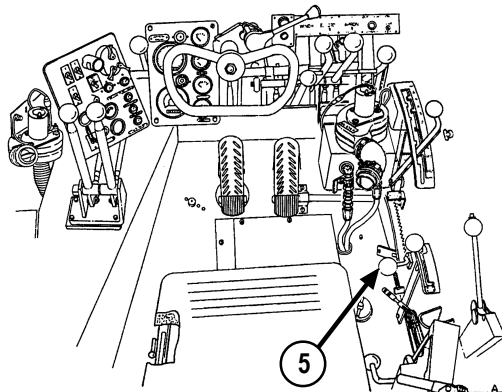
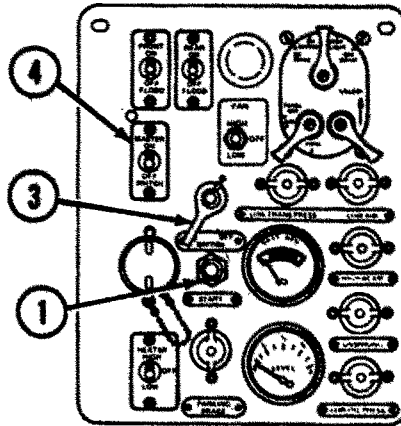

INSTRUMENT PANEL CHECKOUT PROCEDURES

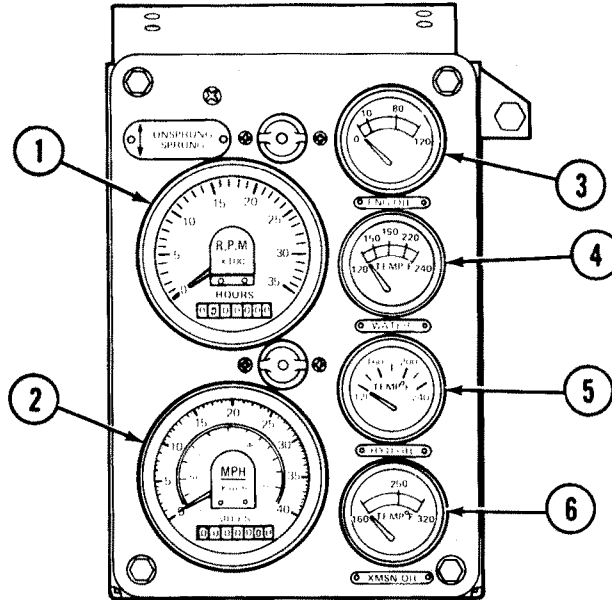

CAUTION

If indicators are not in the normal range with engine warmed up and running, shut off engine and troubleshoot (p 3-2). Failure to comply may result in damage to equipment.

- 1 Tachometer (1). Indicates engine speed in revolutions per minute (rpm). Also contains engine hourmeter which indicates hours engine has run.
- 2 Speedometer/odometer (2). Indicates vehicle speed in miles per hour (mph) and kilometers per hour (km/h). Also indicates total miles traveled.
- 3 ENGINE OIL pressure indicator (3). Indicates engine oil pressure in pounds per square inch (psi). Normal range is 10 to 80 psi (69 kPa to 552 kPa) when vehicle is at operating temperature.
- 4 WATER temperature indicator (4). Indicates temperature of engine coolant fluid in degrees Fahrenheit (°F). Normal range is 150° to 190°F (66° to 88°C).
- 5 HYDRAULIC OIL temperature indicator (5). Indicates temperature of hydraulic system oil in degrees Fahrenheit (°F). Not to exceed 240°F (116°C). During extensive dozing operations, normal range is 140° to 220°F (60° to 104°C).
- 6 TRANSMISSION OIL temperature indicator (6). Indicates temperature of transmission oil in degrees Fahrenheit (°F). Normal range is 160° to 250°F (71° to 121°C).

INSTRUMENT PANEL CHECKOUT PROCEDURES — CONTINUED

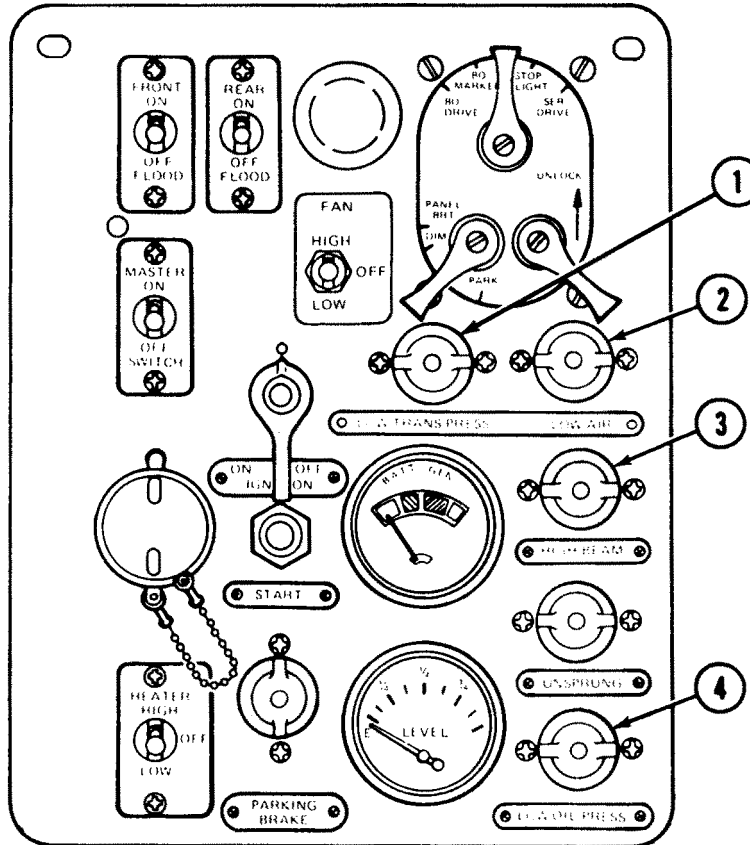

CAUTION

If indicators are not in the normal range with engine warmed up and running, shut off engine and troubleshoot (p 3-2). Failure to comply may result in damage to equipment.

- 7 **LOW TRANSMISSION PRESSURE** indicator (1). Indicates oil pressure is too low to safely operate the vehicle. Should be off during engine operation. May come on momentarily when transmission is shifted.
- 8 **LOW AIR** indicator (2). Indicates brake air pressure is too low to safely operate the service and trailer brakes. Should be off during engine operation.
- 9 **HIGH BEAM** indicator (3). Lights when headlights are on and high beam operation is selected.
- 10 **LOW-OIL PRESSURE** indicator (4). Indicates engine oil pressure is too low to safely operate the vehicle. Should be off during engine operation.

INSTRUMENT PANEL CHECKOUT PROCEDURES — CONTINUED

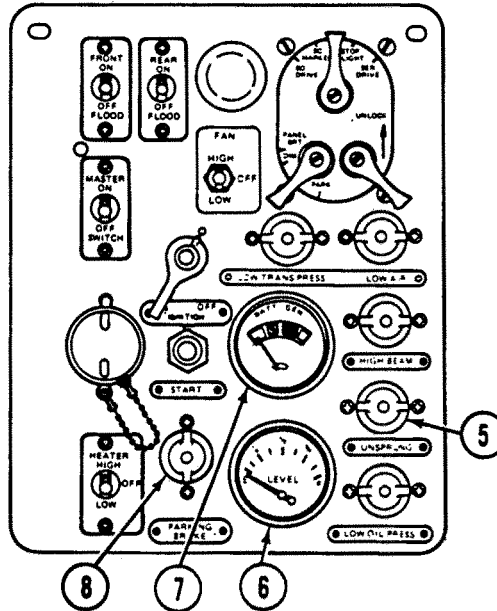

- 11 UNSPRUNG indicator (5). Indicates suspension is in UNSPRUNG mode of operation and transmission is in reverse. Should be off when SPRUNG mode of operation is selected.
- 12 Fuel LEVEL indicator (6). Indicates amount of fuel in fuel tank.
- 13 BATTERY GENERATOR indicator (7). Indicates condition of electrical generating (alternator) system. Needle should be in GREEN during engine operation.

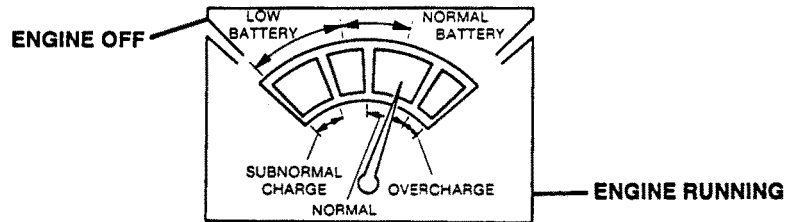

- 14 PARKING BRAKE indicator (8). Indicates parking brake is set. Should go off when parking brake is released.

OPERATION OF LIGHTS

- 1 Turn MASTER SWITCH (1) ON.
- 2 Push safety switch (2) to UNLOCK, and hold in UNLOCK while moving selector switch (3). Release safety switch (2) after selecting lights.

Note

BO DRIVE on selector switch is a nonoperating item on certain vehicles.

- 3 Move selector switch (3) to desired position.
- 4 Select BRT (bright) or DIM panel lights with panel light switch (4).
- 5 Use dimmer switch (5) to select high or low beam of service headlights.

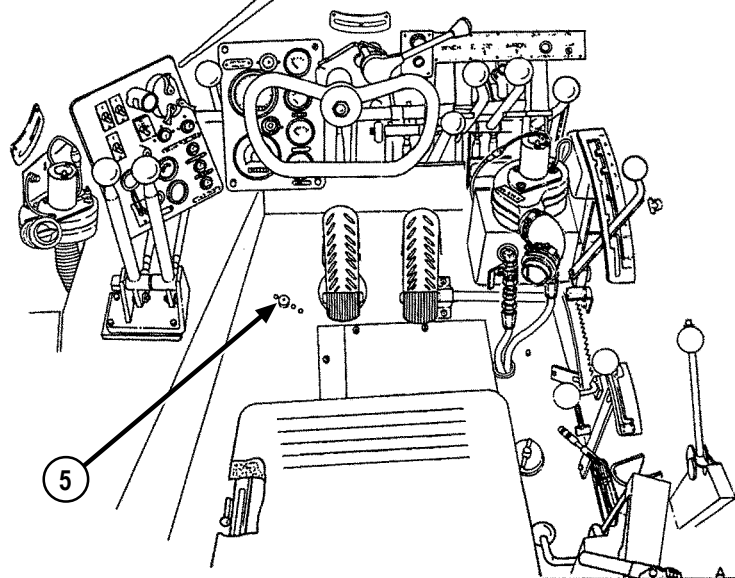
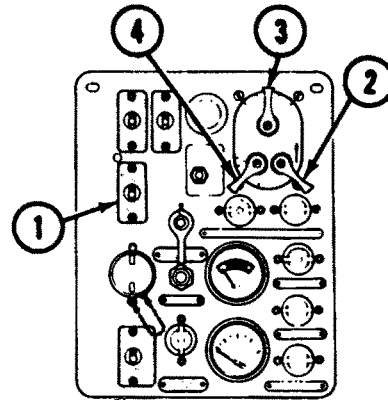

OPERATION OF DOMELIGHT

- 1 Turn MASTER SWITCH (1) ON.
- 2 To select blue light, turn lever (2) fully clockwise.
- 3 To select white light, press safety latch (3) and turn lever (2) counterclockwise past stop.
- 4 To control brightness of domelight, use DOMELIGHT DIMMER control (4).

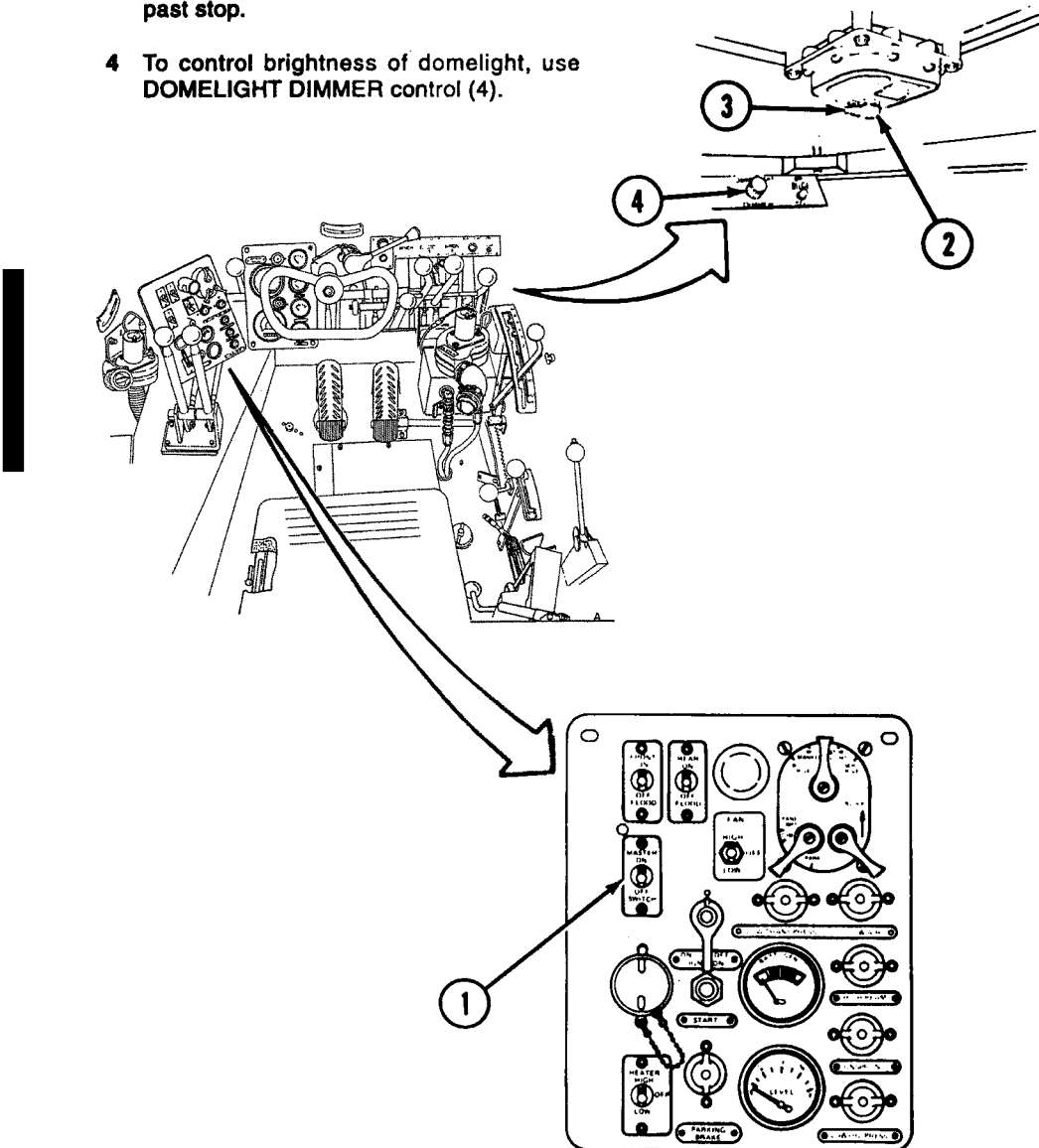

OPERATION OF VENTILATION FAN

- 1 Turn MASTER SWITCH (1) ON.
- 2 Turn FAN switch (2) to LOW or HIGH, depending on level of ventilation desired.

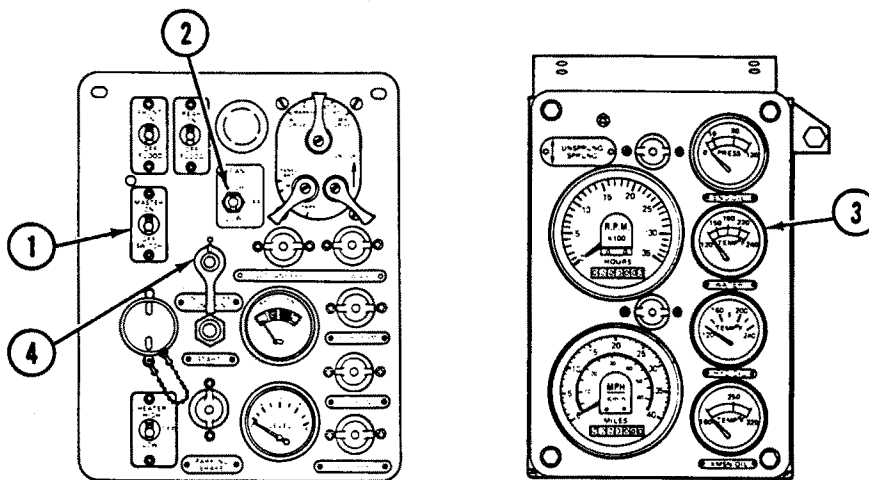

STOPPING THE ENGINE

- 1 If engine temperature is above 190°F (88°C), allow it to run at a fast idle for 3 to 5 minutes to gradually cool down to below 190°F (88°C).
- 2 Set all auxiliary equipment to OFF.
- 3 When engine temperature (3) is under 190°F (88°C), turn IGNITION switch (4) to OFF and turn MASTER SWITCH (1) to OFF.

DRIVING THE VEHICLE

Do not attempt to drive the vehicle until thoroughly familiar with all the controls, instruments, and procedures. Always keep in mind the warnings and cautions found throughout this manual for the safe operation of the vehicle and accessories.

WARNING

The driver's hatch cover must be secured in either the stowed or closed position when operating the vehicle. Failure to comply may result in injury to personnel.

Before placing the vehicle in operation, make sure of the following:

- That the driver's hatch cover is secured in either the stowed or closed position.
- That all basic issue items are stowed and secure.

DRIVING PRECAUTIONS

WARNING

Drive carefully, especially if not experienced with the vehicle. On hard pavement, avoid oversteering and speeding. Control of the vehicle may be lost, and damage to equipment or injury to personnel may result.

CAUTION

- Do not leave vehicle unattended while engine is running.
- Reduce the engine speed momentarily when shifting gears.
- Do not shift into reverse gears unless the vehicle is completely stopped.
- When starting on a hill, depress brake and place transmission in 1 (low) position, increase engine speed, and release brake.
- Do not hold vehicle on an incline by using the accelerator. The transmission will overheat.
- Vehicle can throw track if it is backed in UNSPRUNG mode. Do not make any sharp turns when backing unless suspension is in SPRUNG mode. If track is thrown or otherwise rides off the sprockets or roadwheels, stop the vehicle, but do not apply the brake while vehicle is moving – allow vehicle to coast to a stop. Do not walk the track back on! Damage to track and suspension will result. Follow the maintenance procedures and then reinstall.

DRIVING THE VEHICLE — CONTINUED

DRIVING PRECAUTIONS — CONTINUED

CAUTION – CONTINUED

- Do not coast down grades. Downshift when going down steep hills. Use range 2 or 3 for long grades, and range 1 on steep grades.
- Observe indicators and warning lights while vehicle is being operated. Do not allow engine oil pressure to drop below 40 psi (276 kPa), or water temperature to drop below 150°F (66°C), or go above 190°F (88°C).
- Use CB (clutch-brake) steering when driving at low speed in close quarters.
- If engine stops when vehicle is on a grade, immediately stop vehicle and set parking brake. Move SPRUNG/UNSPRUNG lever to UNSPRUNG position, and lower blade to secure vehicle. On steep grades, immediately block tracks on downhill side.
- If fording is required, check depth before entering water. Do not attempt to ford water that is more than 36 in. (91 cm) deep.
- When shutting down or parking the vehicle, always raise the hull and move SPRUNG/UNSPRUNG lever to SPRUNG position so the hull will rest on the bump stops when hydraulic pressure bleeds down.
- The vehicle does not have an automatic transmission. The transmission must be shifted manually.
- Refer to FM 21-306, Manual for the Track Combat Vehicle Driver, for general tracked vehicle driving precautions on land or in water.

DRIVING THE VEHICLE — CONTINUED

STARTING THE VEHICLE

- 1 Start the engine (p 2-37) and allow it to warm up for 3 to 5 minutes.
- 2 Move the hand throttle (1) all the way back.
- 3 Place SPRUNG/UNSPRUNG control lever (2) in SPRUNG position.

Note

- When shifting into 5th or 6th gear, the CB/GS steer selector automatically shifts into GS. When shifting from 5th or 6th gear to a lower gear, you must manually select CB, if desired.
 - When shifting into R1 or R2, the CB/GS steer selector automatically shifts into CB. When shifting from R1 or R2 into a forward gear, you must manually select GS, if desired.
- 4 Place CB/GS steer selector lever (3) in GS (geared steer) position for normal driving, CB (clutch brake) position for driving in close quarters at low speed.
 - 5 Press brake pedal (4) and release parking brake (5).

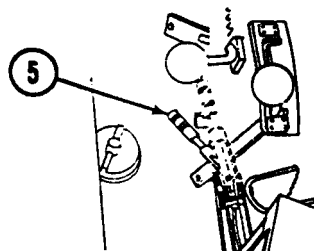
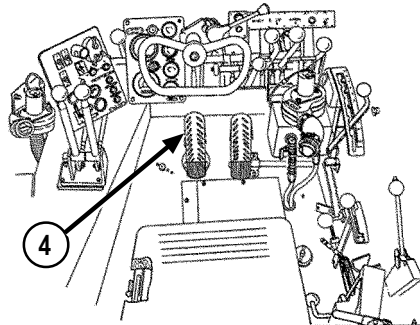
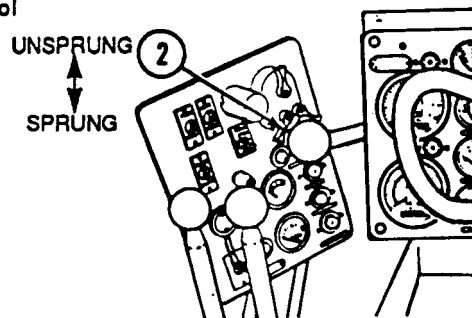
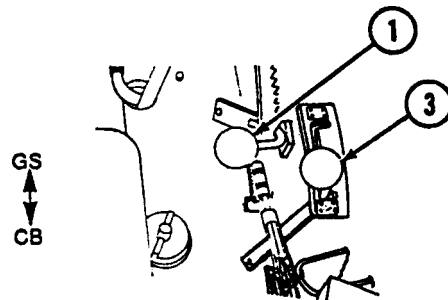

DRIVING THE VEHICLE — CONTINUED

STARTING THE VEHICLE — CONTINUED

- 6 Move transmission shift lever (6) to 1 or 2 for driving forward, R1 or R2 for driving backward (p 2-51).

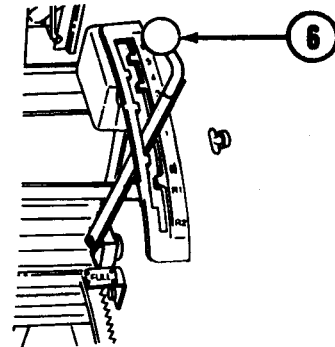

- 7 Release brake pedal (4). Press accelerator (7) to put vehicle in motion and to control vehicle speed.

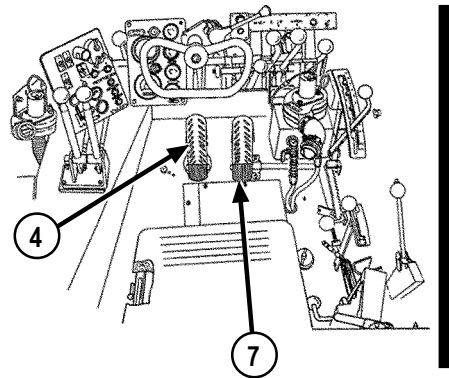

- 8 Use steering wheel (8) to turn vehicle left or right. Turn steering wheel right to turn right, left to turn left, when driving forward or backward (p 2-52).

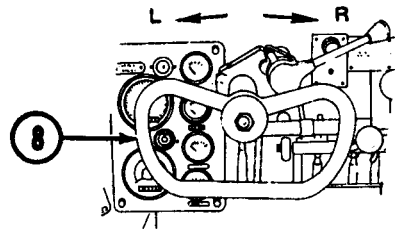

- 9 While driving, check speedometer (9) and tachometer (10). Do not exceed safe speed (30 mph (48.3 km/h)), or allow engine speed to exceed limits (2,800 rpm).

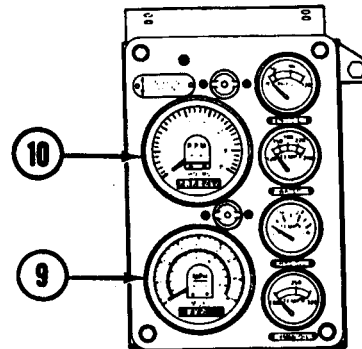

- 10 While operating, perform the "During" PMCS (p 2-20).

DRIVING THE VEHICLE — CONTINUED

STOPPING THE VEHICLE

1 Release accelerator pedal (1) and press brake pedal (2).

2 When vehicle stops:

- Shift transmission shift lever (3) to N (neutral). Press brake pedal (2) and pull parking brake lever (4) up and back, over center.
- Release brake pedal (2).
- Raise front of vehicle with suspension control levers (5), if in UNSPRUNG mode.
- Move SPRUNG/UNSPRUNG control lever (6) to SPRUNG position.

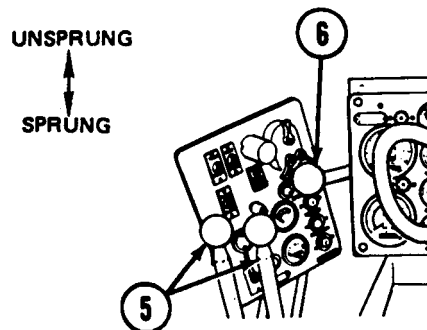
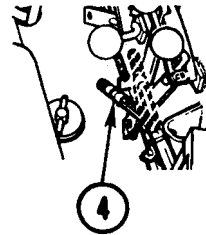
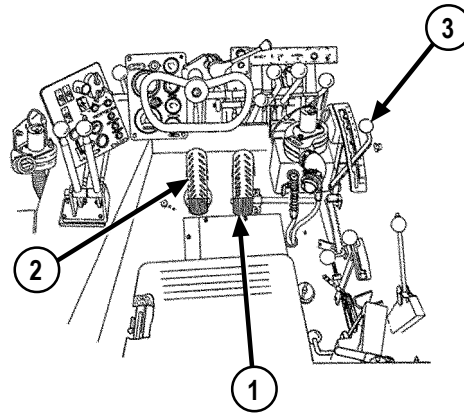

DRIVING THE VEHICLE — CONTINUED

SHIFTING THE TRANSMISSION

Note

- When shifting into 5th or 6th gear, the CB/GS steer selector automatically shifts into GS. When shifting from 5th or 6th gear to a lower gear, you must manually select CB, if desired.
- When shifting into R1 or R2, the CB/GS steer selector automatically shifts into CB. When shifting from R1 or R2 into a forward gear, you must manually select GS, if desired.

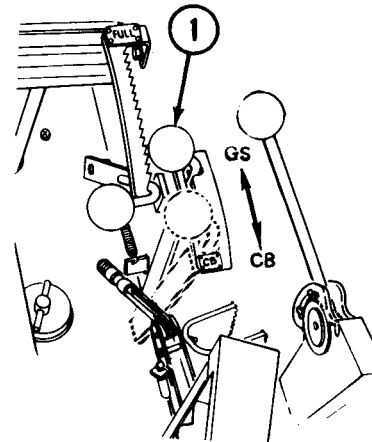

- 1 Select GS (geared steer) position of CB/GS steer selector lever (1) for steering at normal speeds. Use CB (clutch brake) position for steering while driving in close quarters, in ranges 1, 2, 3, and 4.
- 2 Place transmission shift lever in N (neutral) to start engine.

CAUTION

- Shifting transmission between forward and reverse with engine under full power can damage the transmission. Bring vehicle to a full stop when shifting from forward to reverse, or from reverse to forward.
- Never go down an incline with transmission in N (neutral).

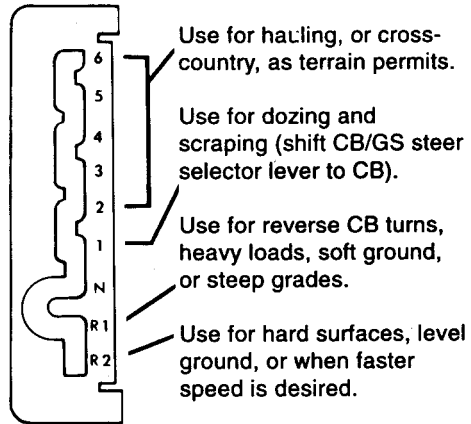

- 3 Move vehicle forward in position 1 or 2. Move vehicle in reverse in position R1 or R2.
- 4 Release accelerator momentarily before shifting transmission to a higher or lower range.
- 5 Shift transmission to a higher range, to drive the vehicle at desired speed, while keeping engine speed at a minimum of 1,800 rpm, maximum 2,800 rpm.

DRIVING THE VEHICLE — CONTINUED

STEERING THE VEHICLE

- 1 Turn steering wheel (1) clockwise to turn right, counterclockwise to turn left.

Note

- When shifting into 5th or 6th gear, the CB/GS steer selector automatically shifts into GS. When shifting from 5th or 6th gear to a lower gear, you must manually select CB, if desired.
- When shifting into R1 or R2, the CB/GS steer selector automatically shifts into CB. When shifting from R1 or R2 into a forward gear, you must manually select GS, if desired.

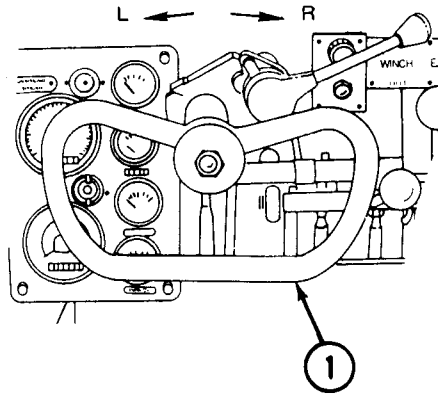

- 2 The amount the steering wheel (1) is turned and the steer selector lever (2) (geared steer or clutch brake) control the turning radius of the vehicle.

With CB/GS steer selector lever (2) in GS (geared steer), the smallest turning radius is 45 ft (13.7 m), to the outside of the vehicle.

With CB/GS steer selector lever (2) in CB (clutch brake), the vehicle pivots around the inside track.

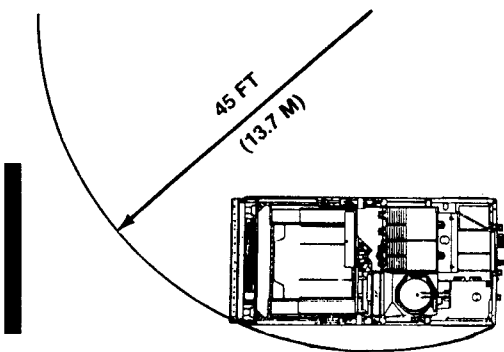
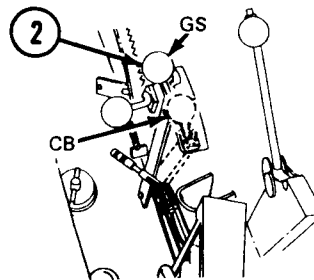

GEARED STEER

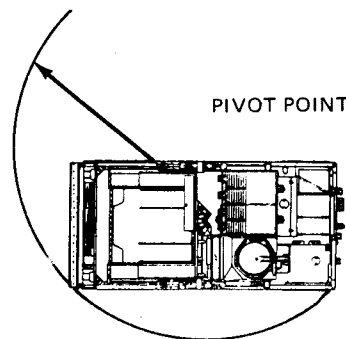

CLUTCH BRAKE

DRIVING THE VEHICLE — CONTINUED
EMERGENCY STOPPING — LOSS OF POWER

WARNING
 Loss of engine power causes loss of steering and rapid loss of brakes because of bleeding off of compressed air. Severe injury to personnel or death may result.

Note
 Set parking brake with engine running and have footbrake applied.

- 1 Press brake pedal (1) and stop vehicle.
- 2 Pull parking brake lever (2) up and over center. Release brake pedal (1).
- 3 On a steep grade, immediately block track on downhill side. Use any available wood blocks, tree trunks, large rocks, etc.
- 4 Start the engine (p 2-37). If engine will not start, troubleshoot (p 3-2) or notify unit maintenance.

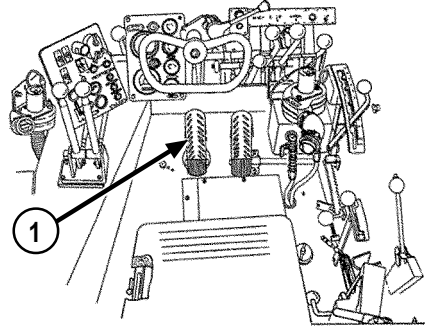

EMERGENCY STOPPING — LOSS OF TRACK

CAUTION
 Do not attempt to walk track back on. Failure to comply may result in damage to track and suspension.

- 1 Do not apply brakes. Allow vehicle to coast to a stop.
- 2 Immediately block roadwheels with any available blocks, tree trunks, large rocks, etc. Brakes do not operate when track is disconnected or removed.

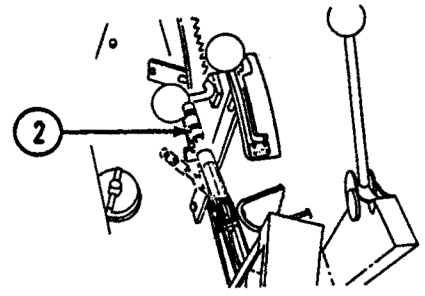

DRIVING THE VEHICLE — CONTINUED

CROSS-COUNTRY DRIVING

CAUTION

Do not travel with the apron raised or without apron lockpins installed. Failure to lock the apron can cause damage to the apron hydraulic cylinders.

- 1 Place SPRUNG/UNSPRUNG control lever (1) in SPRUNG position.

WARNING

Do not drive too fast over rough terrain; the dozer blade, ripper blade, or scraper can dig in, causing the vehicle to stop suddenly or to pitch. Failure to comply may result in damage to equipment or injury to operator.

- 2 The dozer blade will be folded:
 - When required for extended driving over uneven terrain.
 - When required for entering or leaving water at a steep bank.
 - When required for more ground clearance.
- 3 During normal cross-country operation, the bowl should be empty. However, for some terrain or soil conditions, vehicle performance may be improved by adding ballast in the bowl. The operator must determine the need for filling the bowl during cross-country operation.

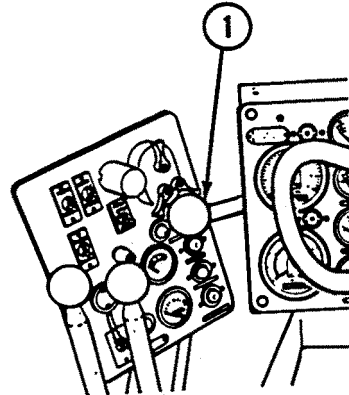

TOWING THE VEHICLE

CAUTION

- Disconnect final drives before towing to prevent damage to the steer unit.
- Turn towing vehicle in a wide arc to prevent undue strain on suspension of disabled vehicle and tow bar.
- Do not tow disabled vehicles over 5 mph (8 km/h).
- Use a tow bar when towing a disabled vehicle with the final drives disconnected. When towing a disabled vehicle in N (neutral), there is a danger of the towed vehicle overrunning the towing vehicle.
- The apron cylinders can be damaged if the vehicle is towed from the front. Use the rear tow brackets or shackles only to tow the M9.

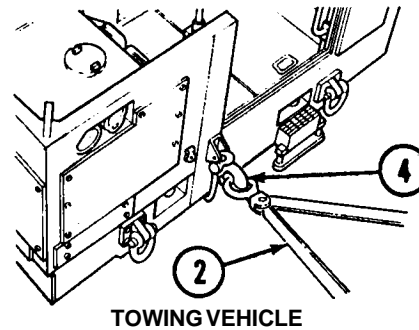
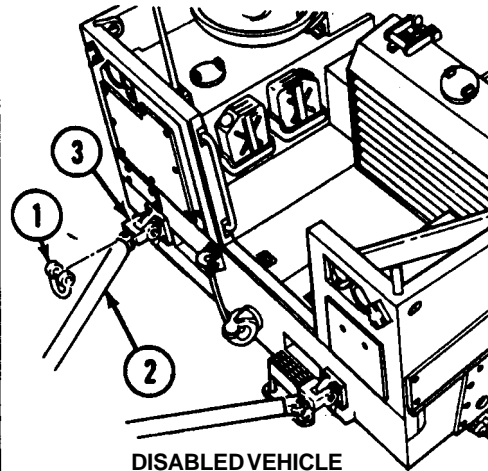

- 1 Make sure the disabled vehicle is in the SPRUNG position. If necessary, manually extend bump stops (p 2-114).
- 2 Disconnect final drives (p 2-116).
- 3 Remove two tow shackles (1) from disabled vehicle and store in vehicle.
- 4 Attach tow bar (2) to tow lugs (3) of disabled vehicle and pintle hook (4) of towing vehicle.
- 5 Shift transmission shift lever (5) to N (neutral) in towed vehicle.
- 6 When towing the vehicle at night, lights should be turned on to suit the tactical situation. All other switches and controls should be OFF.

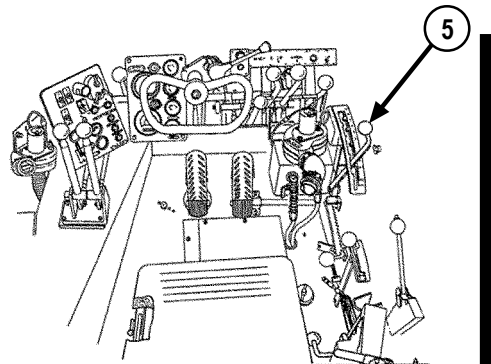

FOLDING THE DOZER BLADE

WARNING

Do not work under vehicle unless hull is blocked and apron lockpins are installed. Failure to comply may result in severe injury to personnel or death.

CAUTION

Remove shovel and chain from storage location on apron to prevent damage.

- 1 Remove shovel (1) and chain (2) from apron (3).
- 2 Start the engine (p 2-37) and allow it to warm up for 3 to 5 minutes.
- 3 Place SPRUNG/UNSPRUNG control lever (4) in SPRUNG position.

WARNING

Do not operate ejector when personnel are in bowl. Do not work in bowl unless ejector lock is engaged. Failure to comply may result in severe injury to personnel.

- 4 Move ejector stop (5) away from ejector control lever (6), and move ejector (7) forward to within about 2 ft (61 cm) of apron (3).

WARNING

Do not stand or work under raised apron assembly unless apron lockpins are installed. Apron assembly can drop, causing severe injury to personnel or death.

- 5 Push apron control lever (8) forward and raise apron (3) to full open position.

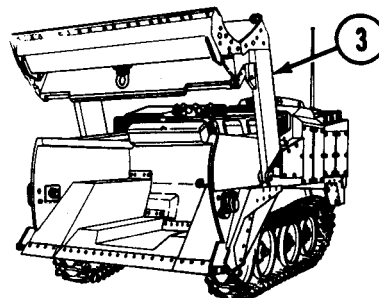
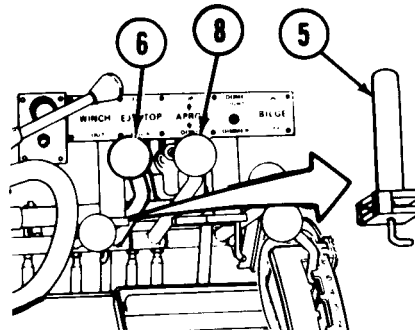
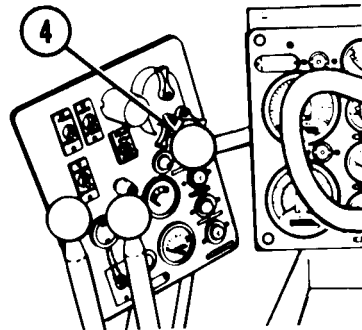
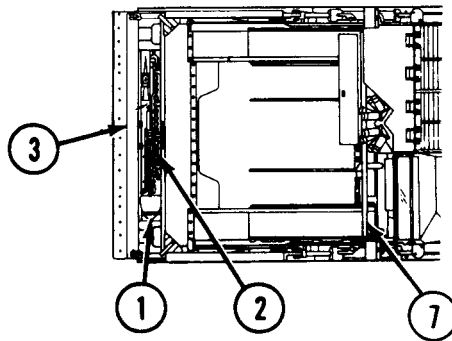

FOLDING THE DOZER BLADE — CONTINUED

- 6 Install apron lockpins (9) in apron (3).
- 7 With apron (3) raised and apron lockpins (9) installed, mark position where apron (3) and lockpin bracket (10) are aligned. After marking alignment point, this mark may be used by operator to align position of apron (3) for lockpin (9) installation, without leaving driver's compartment.
- 8 Thread about ten links of chain (2) through shackle (11) on back side of dozer blade (12), then secure chain (2) with hook (13).
- 9 Chain (2) length is correct when free end of chain (2) just reaches the last screw (14) of forward track retainer (15), with chain (2) against bottom of apron lockpin stowage bracket (16) and tiedown shackle (17).
- 10 Place free end of chain (2) on ground in front of vehicle.
- 11 Remove apron lockpins (9) and lower apron (3).
- 12 Feed chain (2) over top of apron (3) and attach to lifting eye (18) on front of ejector (7).

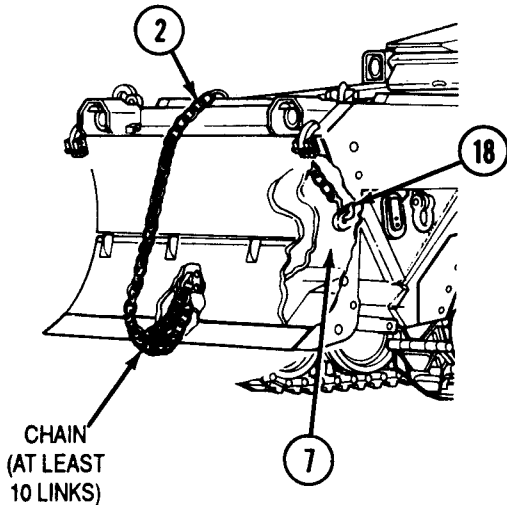
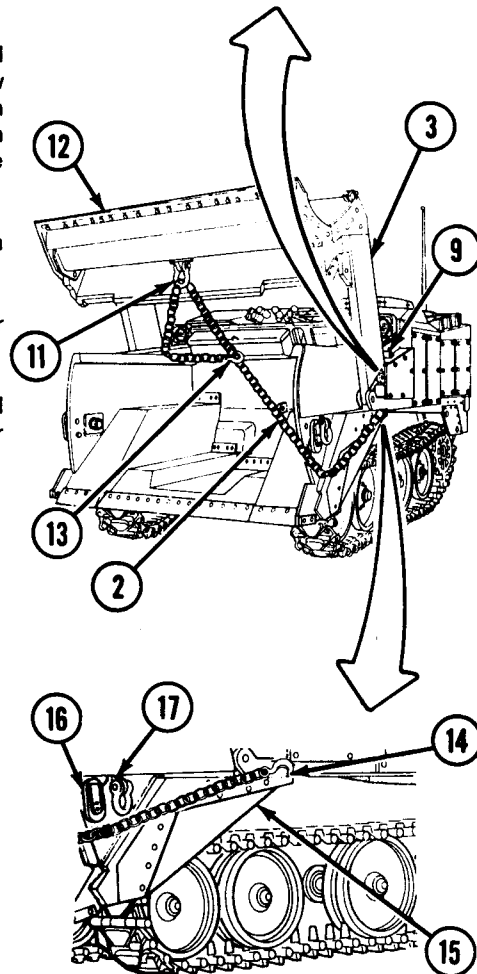
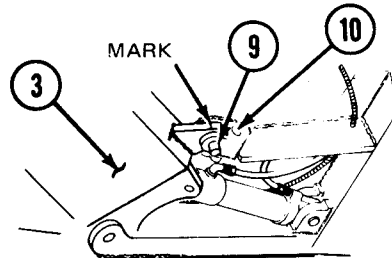

FOLDING THE DOZER BLADE — CONTINUED

- 13 Remove pin assembly (1) and dozer blade latch (2) from each side of apron (3).
- 14 Remove two clips (4), then drive through or pull out two dozer blade lockpins (5).

WARNING

- Do not operate ejector when personnel are in bowl. Do not work in bowl unless ejector lock is engaged. Failure to comply may result in severe injury to personnel.
- Do not stand in front of dozer blade while retracting ejector. Failure to comply may result in severe injury to personnel.
- When folding dozer blade, work on blade latches from side of vehicle only. Failure to comply may result in serious injury to personnel.

CAUTION

Do not put continued pressure on chain once blade is folded against apron. Failure to comply may result in damage to equipment.

Note

If ripper blade is used, the words "RIPPER BLADE" shall be facing out, and if cutting edge is used, the words "STANDARD BLADE" shall be facing out.

- 15 Retract ejector (6) until dozer blade (7) is folded against apron (3).
- 16 Secure dozer blade (7) by installing dozer blade latch (2) in forward position, with pin assembly (1) on each side of apron (3) in middle hole.
- 17 Release tension on chain (8) by inching ejector (6) forward.
- 18 Remove chain (8) from dozer blade (7) and ejector (6).
- 19 Install two dozer blade lockpins (5) in dozer blade (7), and secure dozer blade lockpins (5) with two clips (4).
- 20 Install chain (8) and shovel (9) on apron (3).

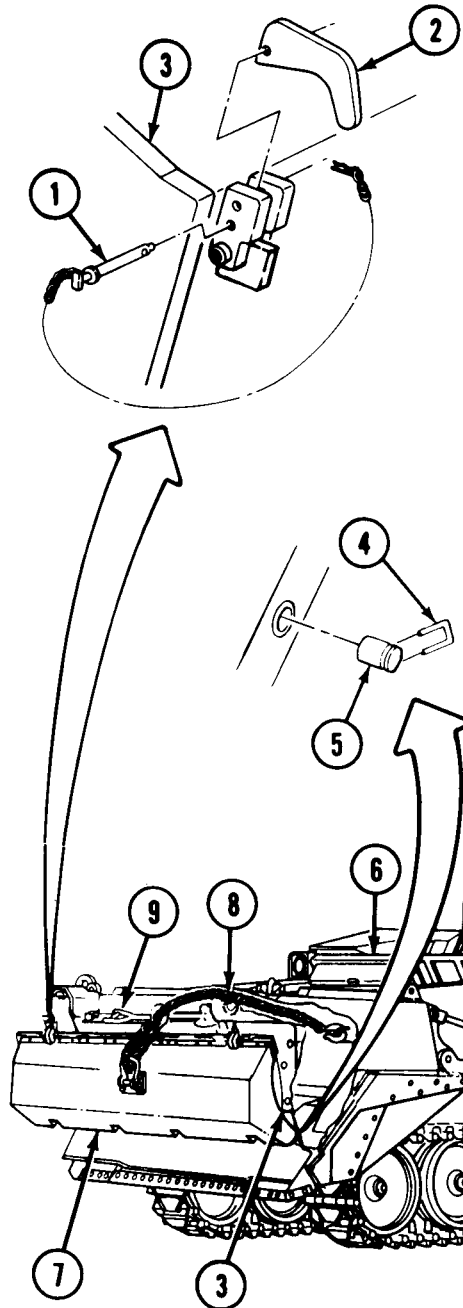

UNFOLDING THE DOZER BLADE

WARNING

If ripper blade is installed, do not unfold blade when driving cross-country. Failure to comply may result in damage to equipment or injury to personnel.

- 1 Start the engine (p 2-37) and allow it to warm up for 3 to 5 minutes.
- 2 Place SPRUNG/UNSPRUNG control lever (1) in SPRUNG position.

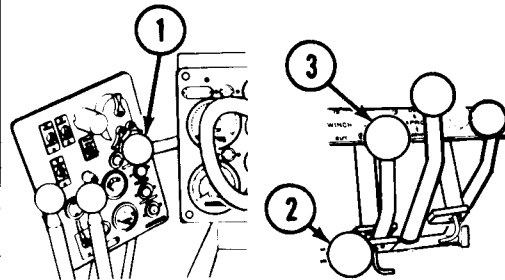

WARNING

- Do not operate ejector when personnel are in bowl. Do not work in bowl unless ejector lock is engaged. Failure to comply may result in severe injury to personnel.
- Do not stand in front of dozer blade while retracting ejector. Failure to comply may result in severe injury to personnel.

- 3 Move ejector stop (2) away from ejector control lever (3) and move ejector (4) forward to within about 2 ft (61 cm) of apron (5).

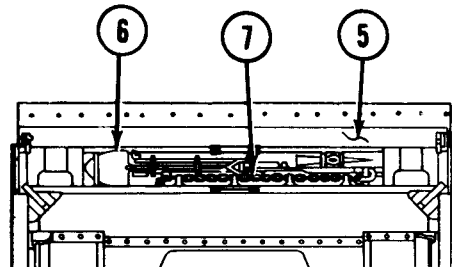

CAUTION

Remove shovel and chain from storage location on apron to prevent damage.

- 4 Remove shovel (6) and chain (7) from apron (5).

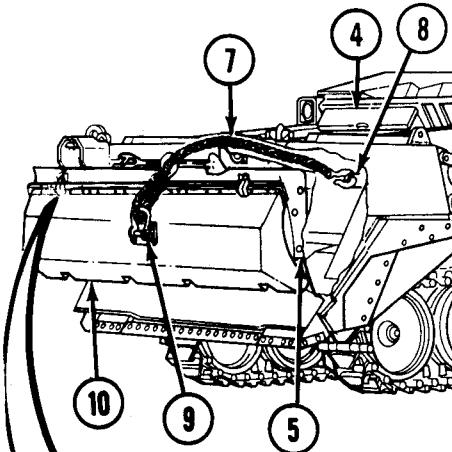

CAUTION

Do not put continued pressure on chain once blade is folded against apron. Failure to comply may result in damage to equipment.

- 5 Attach chain (7) to lifting eye (8) on ejector (4). Thread free end of chain (7) through shackle (9) of dozer blade (10) and secure chain (7). Loop in chain (7) should consist of approximately 10 links. Retract ejector (4) to remove slack from chain (7).

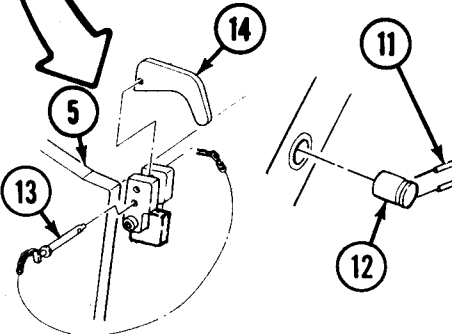

WARNING

When unfolding dozer blade, work on blade latches from side of vehicle only. Failure to comply may result in serious injury to personnel.

6. Remove two clips (11). Drive through or pull out two dozer lockpins (12). Remove pin assembly (13) and blade latch (14) from each side of apron (5).

UNFOLDING THE DOZER BLADE — CONTINUED

WARNING
 Do not operate ejector when personnel are in bowl. Do not work in bowl unless ejector lock is engaged. Failure to comply may result in severe injury to personnel.

- 7 Move ejector stop (1) away from ejector control lever (2) and slowly move ejector (3) forward to lower dozer blade (4). Move ejector (3) completely forward and engage ejector stop (1) to ejector control lever (2).
- 8 Install two dozer blade lockpins (5) and two clips (6).
- 9 Install blade latch (7), facing rearward, with pin assembly (8) on each side of apron (9).
- 10 Remove chain (10) from ejector (3), and lay chain (1) in front of vehicle in the top hole.

WARNING
 Do not stand or work under raised apron assembly unless apron lockpins are installed. Apron assembly can drop, causing severe injury to personnel or death.

- 11 Push apron control lever (11) forward and raise apron (9) to full open position.
- 12 Install apron lockpins (12) on apron (9).
- 13 Remove chain (10) from dozer blade (4).
- 14 Remove apron lockpins (12) and lower apron (9). Retract ejector (3).
- 15 Install shovel (13) and chain (10) on apron (9).

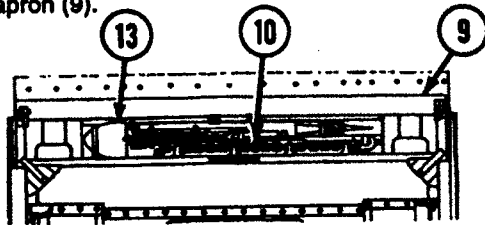
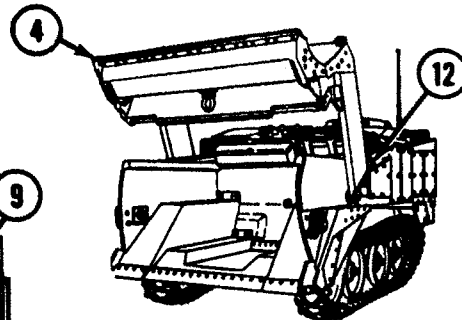
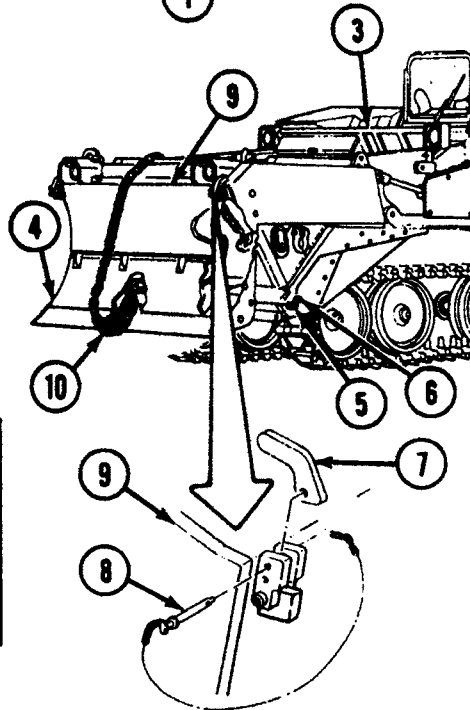
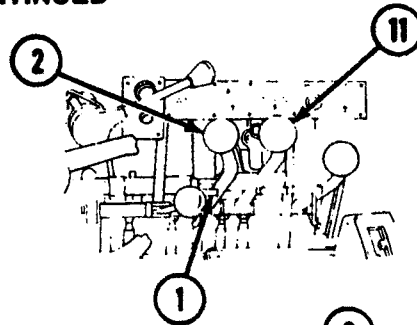

PALLETIZED CARGO HANDLING

LOADING PALLET

- 1 Start the engine (p 2-37) and allow it to warm up for 3 to 5 minutes.
- 2 Remove chain (1) from apron stowage.

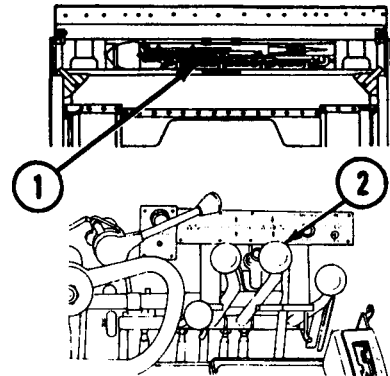

WARNING

Do not stand or work under raised apron assembly unless apron lockpins are installed. Apron assembly can drop, causing severe injury to personnel or death.

- 3 Push apron control lever (2) forward, and raise apron (3) to full UP position.
- 4 Have helper install two apron lockpins (4) in apron (3).
- 5 Position vehicle near pallet.

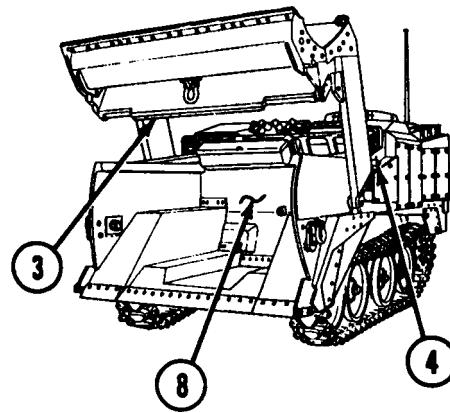

WARNING

Do not operate ejector when personnel are in bowl. Do not work in bowl unless ejector lock is engaged. Failure to comply may result in severe injury to personnel.

- 6 Place vehicle controls in positions as shown below.
 - CB/GS Steer Selector (5) GS
 - SPRUNG/UNSPRUNG (6) UNSPRUNG
 - Transmission (7) NEUTRAL
 - Ejector (8) Forward

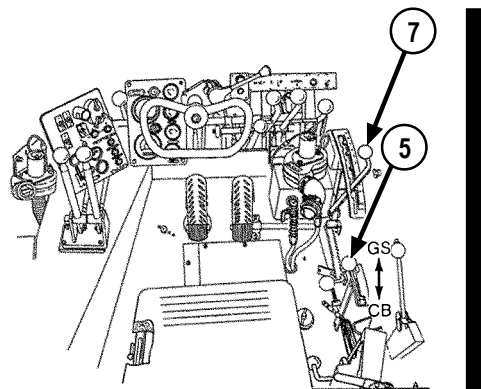
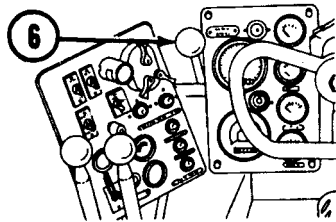

PALLETIZED CARGO HANDLING - CONTINUED

LOADING PALLET - CONTINUED

- 7 Push both suspension control levers (1) forward, and lower front of vehicle until scraper cutting edge (2) rests on ground.
- 8 Attach chain (3) to pallet and to lifting eye (4) on ejector (5).

WARNING
Do not operate ejector when personnel are in bowl. Do not work in bowl unless ejector lock is engaged. Failure to comply may result in severe injury to personnel.

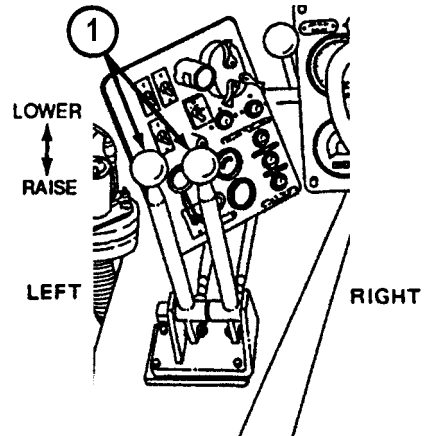

- 9 Slowly retract ejector (5) until pallet is pulled into bowl. If necessary, move ejector (5) forward, shorten chain (3), and pull pallet all the way into bowl.
- 10 Disconnect chain (3) from ejector (5). Have helper remove two apron lockpins (6), then raise front of vehicle and lower apron (7). Place suspension in SPRUNG mode.
- 11 Stow chain (3) on apron (7).

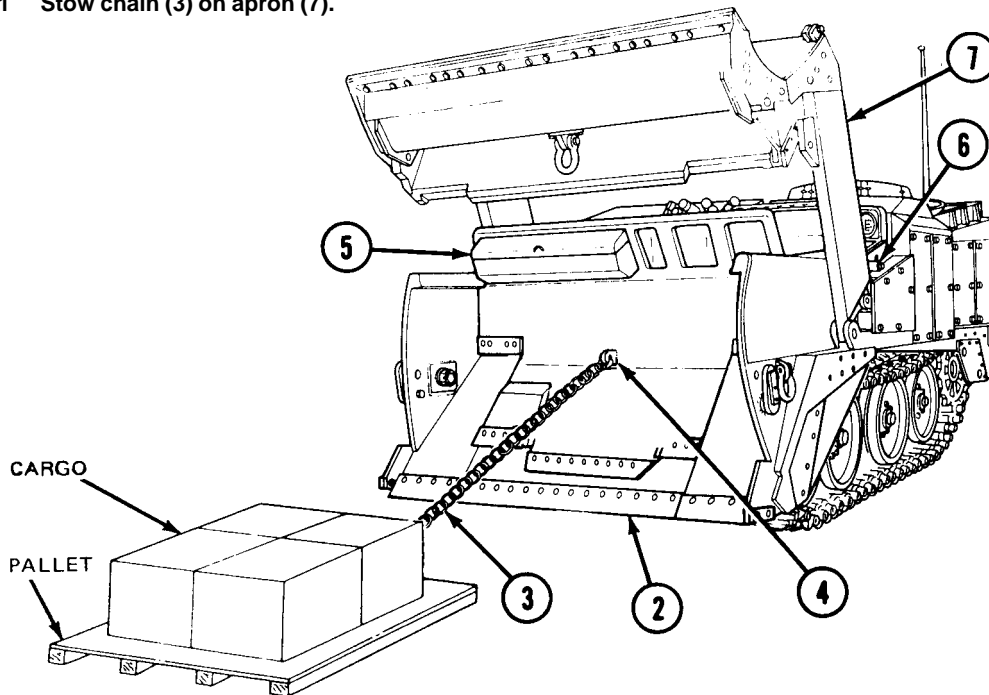

PALLETIZED CARGO HANDLING — CONTINUED

UNLOADING PALLET

WARNING

Do not stand or work under raised apron assembly unless apron lockpins are installed. Apron assembly can drop, causing severe injury to personnel or death.

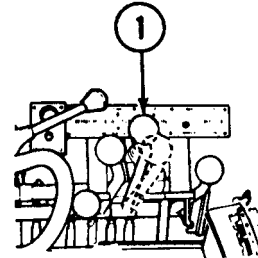

- 1 Push apron control lever (1) forward and raise apron (2) to full UP position. Install two apron lockpins (3).

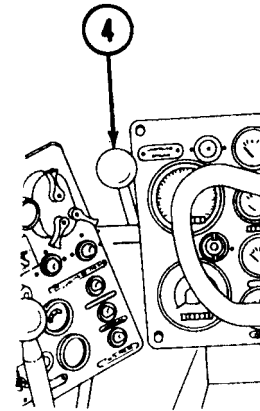
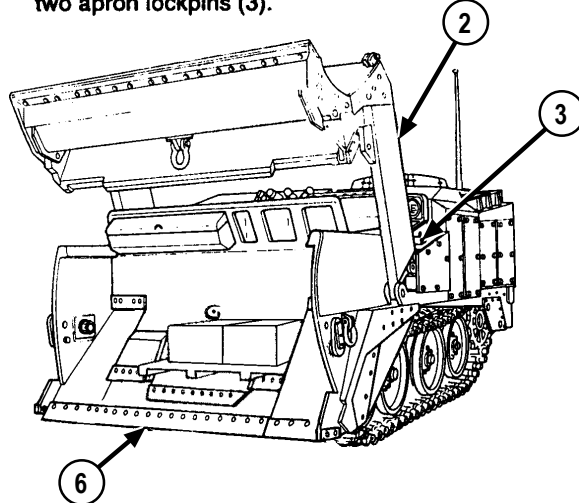

- 2 Place SPRUNG/UNSPRUNG control lever (4) in UNSPRUNG position.

- 3 Push both suspension control levers (5) forward and lower front of vehicle until scraper cutting edge (6) rests on ground.

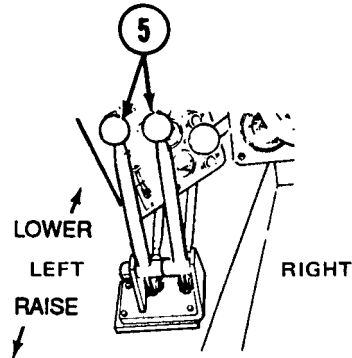

PALLETIZED CARGO HANDLING — CONTINUED

UNLOADING PALLET — CONTINUED

WARNING

Do not operate ejector when personnel are in bowl. Do not work in bowl unless ejector lock is engaged. Failure to comply may result in severe injury to personnel.

- 4 Slowly move ejector control lever (1) forward so ejector (2) will push pallet out of bowl.

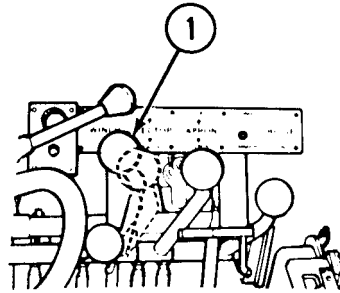

Note

If pallet hangs on edge of bowl, slowly back vehicle away from pallet.

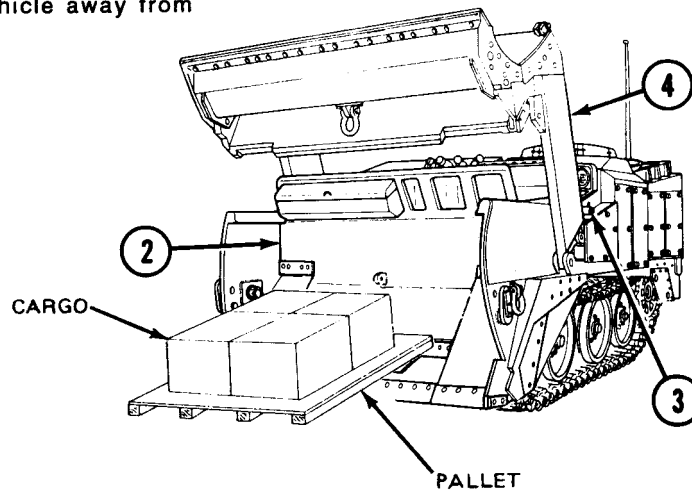

- 5 When pallet is out of bowl, remove two apron lockpins (3). Raise front of vehicle, place suspension in SPRUNG mode, and lower apron (4).

SCRAPER OPERATION

LOADING THE BOWL

- 1 Start the engine (p 2-37) and allow it to warm up for 3 to 5 minutes.

Note

Use CB position for short turns or for more traction.

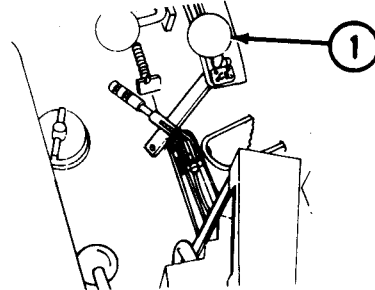

- 2 Place CB/GS steer selector lever (1) in CB (clutch brake) position.

- 3 Place SPRUNG/UNSPRUNG control lever (2) in UNSPRUNG position.

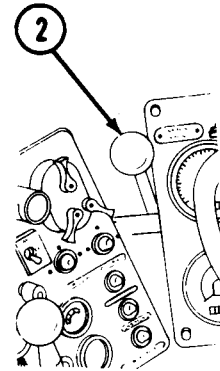

- 4 Move apron control lever (3) to UP and raise apron 12 to 18 in. (30 to 46 cm). Height of apron will depend on type of material to be loaded.

WARNING
 Do not operate ejector when personnel are in bowl. Do not work in bowl unless ejector lock is engaged. Failure to comply may result in severe injury to personnel.

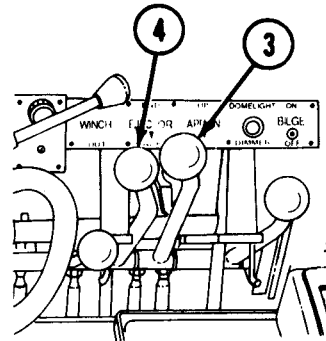

- 5 Move ejector control lever (4) back to fully retract ejector.

SCRAPER OPERATION — CONTINUED

LOADING THE BOWL — CONTINUED

- 6 Place transmission shift lever (1) in first gear, and gradually accelerate engine.
- 7 When vehicle begins to move forward, push both suspension control levers (2) forward to lower scraper (3).

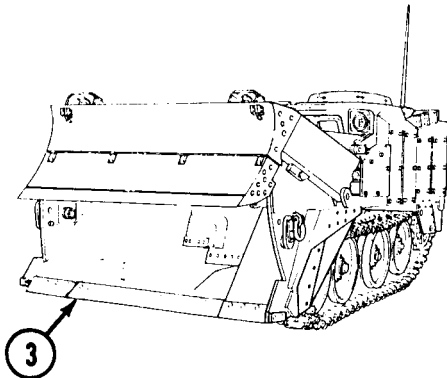
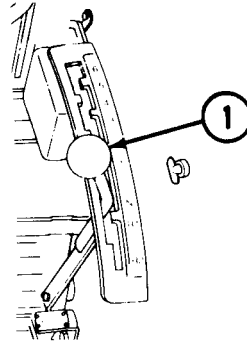

Note

In some terrain or soil conditions, vehicle may dig unevenly or not maintain cuts with ripper blade installed.

- 8 Use scraper (3) to make a 3 to 4 in. (8 to 10 cm) cut, or vary size of cut, according to surface and material to be loaded.

Note

Bowl capacity is 8.7 cu yd (6.7 cu m).

- 9 When bowl is filled, lower apron and move suspension control levers (2) back to raise front of vehicle. Place SPRUNG/UNSPRUNG control lever (4) in SPRUNG position.

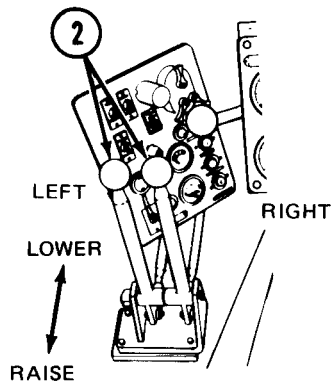

- 10 Before moving to next work site:

- Remove excess dirt from scraper area.
- Install apron lockpins if necessary.

SCRAPER OPERATION — CONTINUED

DUMPING AND SPREADING

- 1 Move apron control lever (1) forward and raise apron (2) to full UP position.
- 2 Place suspension in SPRUNG mode.

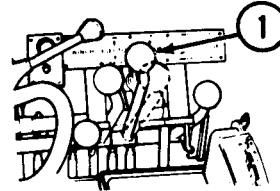

Note

Spreading can be done with the vehicle moving forward or reverse. This procedure covers forward spreading.

- 3 To spread material:
 - While driving the vehicle slowly forward, gradually move the ejector (3) forward.
 - Control the depth of the spread material by changing speed of vehicle and speed of ejector (3).

CAUTION

Track can be thrown if vehicle is backed in UNSPRUNG mode. Do not make any sharp turns when backing unless suspension is in SPRUNG mode. Failure to comply may result in damage to equipment.

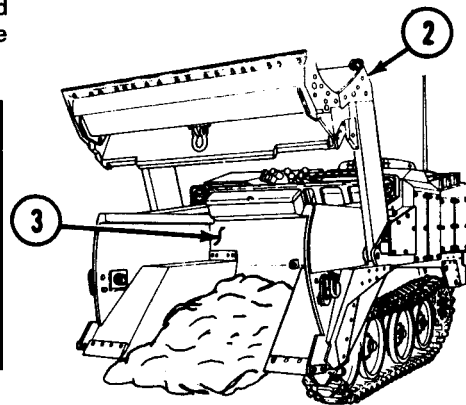

- 4 To pile or dump material:
 - Leave suspension in SPRUNG mode and use ejector (3) to push material out of bowl.
 - Back vehicle as necessary.
- 5 When scraper operation is completed:
 - Lower apron (2).
 - Retract ejector (3).

DOZER OPERATIONS

STRAIGHT DOZING

Note

Use CB position for short turns or for more traction.

- 1 Start the engine (p 2-37) and allow it to warm up for 3 to 5 minutes.
- 2 Use vehicle as a scraper (p 2-65) and fill bowl completely with earth for use as ballast.

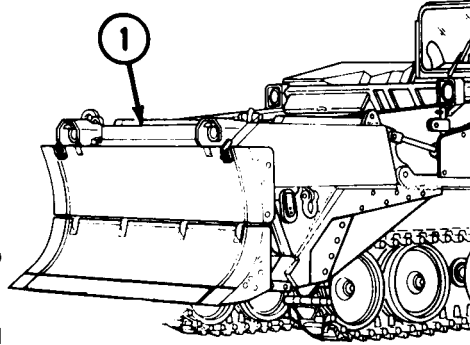

CAUTION

Apron must be fully lowered into contact with the hull during dozing operation.

- 3 Raise and lower apron (1) several times to make sure it makes full contact with the hull.
- 4 Place SPRUNG/UNSPRUNG control lever (2) in UNSPRUNG position.

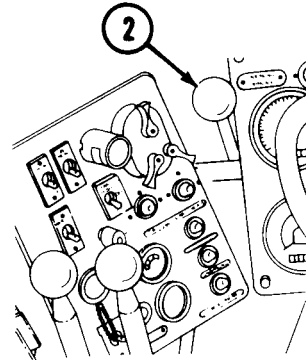

Note

In some terrain or soil conditions, vehicle may dig unevenly or not maintain cuts with ripper blade installed.

- 5 Slowly move both suspension control levers (3) forward until dozer blade rests on ground.
- 6 Select CB (clutch brake) position of CB/GS steer selector lever (4).

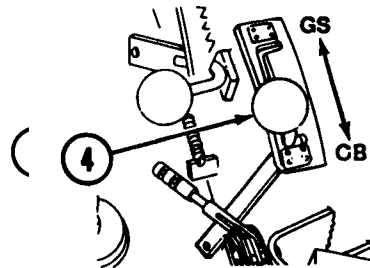
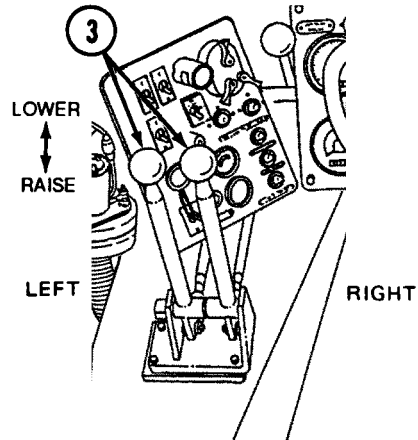

DOZER OPERATIONS — CONTINUED

STRAIGHT DOZING — CONTINUED

- 7 Place transmission shift lever (5) in 1, and press accelerator (6) to move vehicle forward.

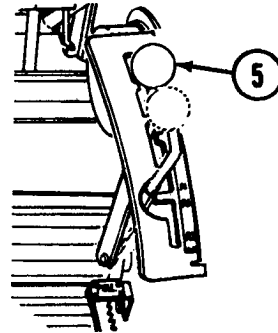

CAUTION

If ripper blade is installed, do not straight doze through solid rock, concrete, or asphalt or extensive damage to scarifier teeth and dozer blade will result.

Note

Use of M9 for dozing is most efficient when engine speed is between 1,900 to 2,200 rpm.

- 8 Control dozer operation by working accelerator (6) and both suspension control levers (3). Do not try to steer vehicle with steering wheel during dozing operation. If dozer blade digs in too much or seems to be overloading, raise suspension (dozer blade) a little.

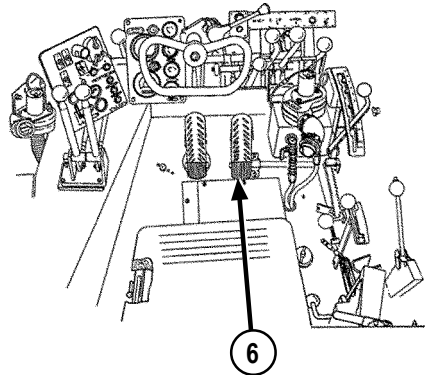

CAUTION

- Bring vehicle to a complete stop before shifting transmission from a forward gear to reverse, or from reverse to forward. Failure to comply may result in damage to equipment.
- Track can be thrown if vehicle is backed in UNSPRUNG mode. Do not make any sharp turns when backing unless suspension is in SPRUNG mode. Failure to comply may result in damage to equipment.

- 9 Slowly move both suspension control levers (3) to raise or lower dozer blade to control depth of cut as vehicle is moving forward.

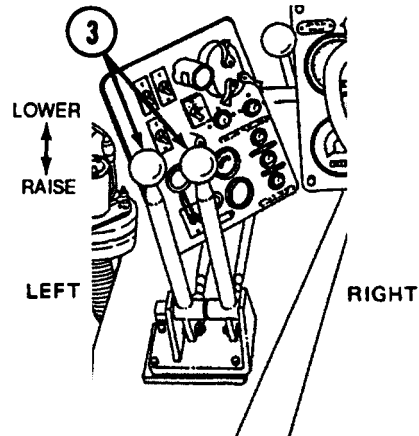

DOZER OPERATIONS — CONTINUED

TILT DOZING

CAUTION

It is important to note that the steering wheel is to be gently manipulated during tilt dozing to keep the vehicle in a straight line. Excessive use or hard turns with the steering wheel can cause the vehicle to lose a track in the UNSPRUNG mode.

- 1 Prepare the vehicle for straight dozing (p 2-68). Suspension must be in the UNSPRUNG mode and the steer selector in GS (geared steer) position.

TILT TO RIGHT
(Left side high)

Note

Try to keep working area to left of vehicle. Visibility is much better from left side of vehicle.

- 2 To tilt to the right (left side high), pull left suspension control lever (1) back and push right suspension control lever (2) forward.

TILT TO LEFT
(Right side high)

- 3 To tilt to the left (right side high), pull right suspension control lever (2) back and push left suspension control lever (1) forward.
- 4 Vehicle tilt can be adjusted from full left to full right, with vehicle moving, by pushing and pulling the suspension control levers.

CAUTION

If ripper blade is installed, do not tilt doze through solid rock, concrete, or asphalt or extensive damage to scarifier teeth and dozer blade will result.

- 5 The operator should take shallow cuts while tilt dozing in geared steer to prevent premature wear of the steer unit.

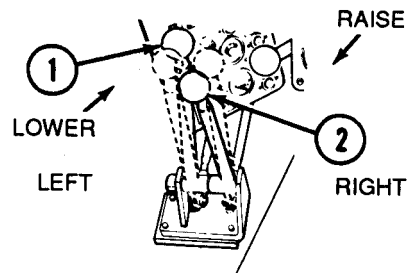
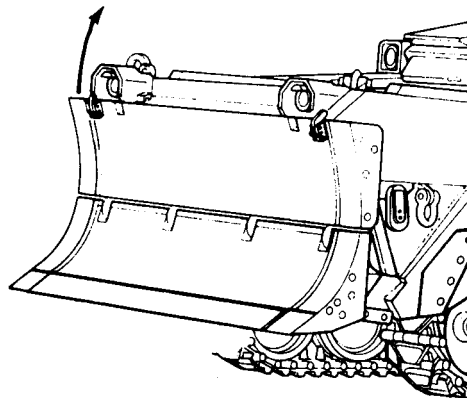
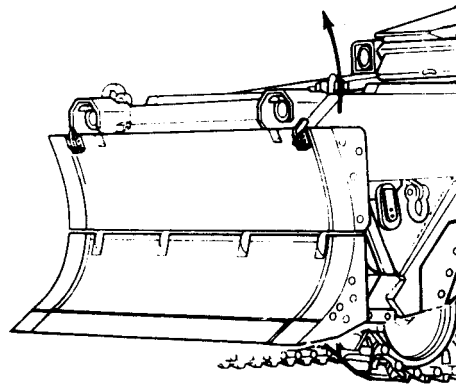
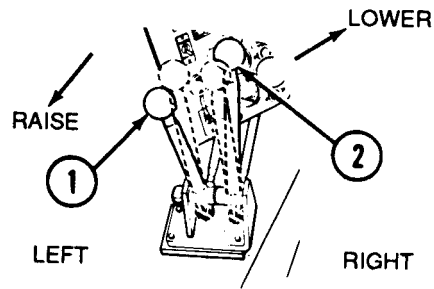

DOZER OPERATIONS - CONTINUED

ROUGH GRADING

- 1 Start engine (p 2-37) and allow it to warm up for 3 to 5 minutes; then drive vehicle to operation.
- 2 Place SPRUNG/UNSPRUNG control lever (1) in UNSPRUNG position.

CAUTION

If ripper blade is installed, do not rough grade through solid rock, concrete, or asphalt or extensive damage to scarifier teeth and dozer blade will result.

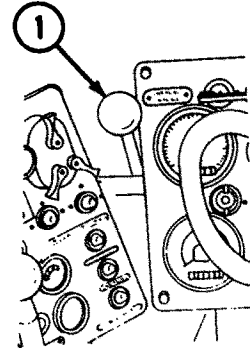

- 3 Operate vehicle as scraper (p 2-65) to load ballast.

Note

In some terrain or soil conditions, vehicle may dig unevenly or not maintain cuts with ripper blade installed.

- 4 Operate vehicle as dozer (p 2-66) and lower suspension to obtain desired depth of cut as vehicle moves forward.

CAUTION

Track can be thrown if vehicle is backed in UNSPRUNG mode. Do not make any sharp turns when backing unless suspension is in SPRUNG mode. Failure to comply may result in damage to equipment.

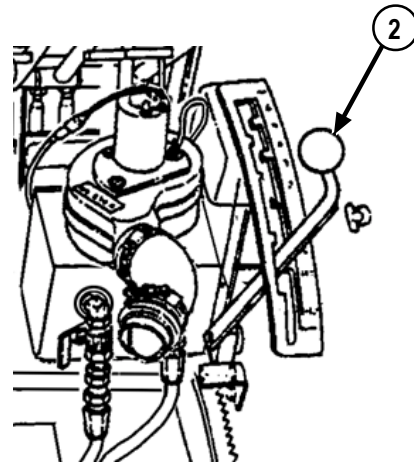

Note

- Controls are in same positions for rough grading, or back-blading, as they are for straight dozing. Back-blading is done in R1 or R2.
- Warning buzzer will sound when backing vehicle in UNSPRUNG mode.

- 5 To back-blade at end of pass, move transmission shift lever (2) to R1 or R2. Coordinate suspension control levers (3) to keep dozer blade dragging on ground over areas just dozed.

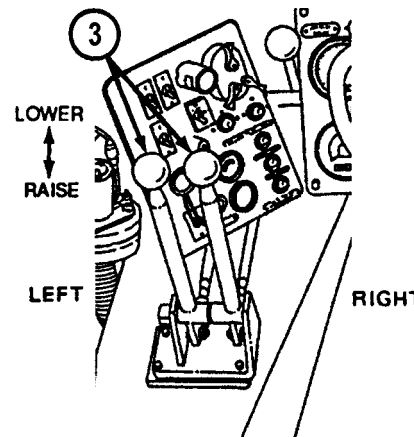

WINCH OPERATION

WARNING

Do not operate winch with one or more cable strands kinked or broken. Failure to comply may result in severe injury to personnel or death.

Note

- Winch operations require one additional person to assist vehicle operator.
- Before beginning winching operations, secure hatch cover in 15° position.

- 1 Start engine (p 2-37) and allow it to warm up for 3 to 5 minutes; then drive vehicle to operation site.

CAUTION

Winch and wire rope can be damaged if wire rope is not in a straight line with the winch drum and the load.

- 2 To use winch for self recovery, refer to page 2-119 and to FM 20-22.

Note

If required, the bowl may be loaded (p 2-65) to provide greater traction.

- 3 Move winch shift lever (1) to HIGH (handle down).

WARNING

Always wear leather gloves when handling wire rope. Never allow wire rope to run through hands. Broken or frayed wires can cause injury.

- 4 Move winch stop (2) away from winch control lever (3), and move winch control lever (3) to OUT position and pay out approximately 2 ft (61 cm) of wire rope.
- 5 Lift winch wire rope hook (4) from hull bracket (5).

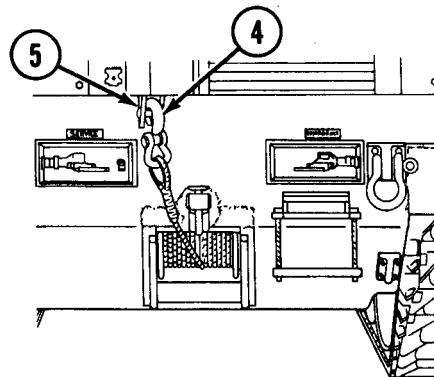
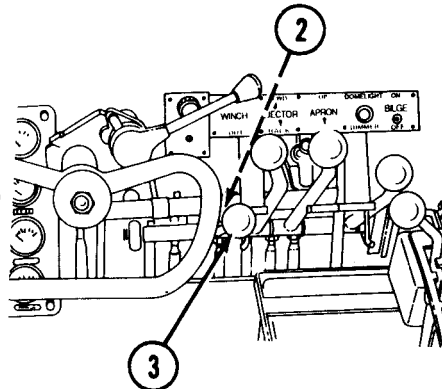
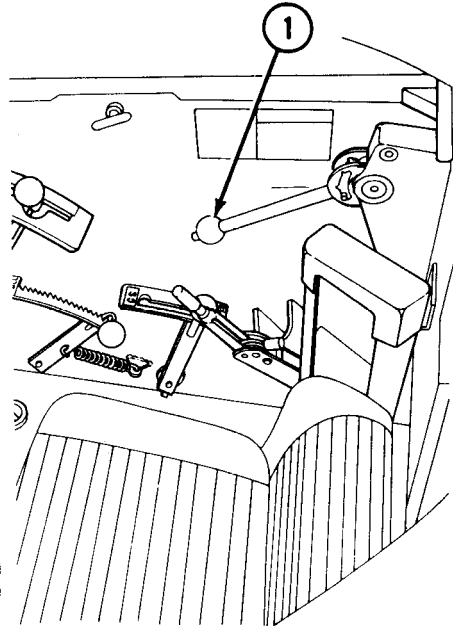

WINCH OPERATION - CONTINUED

WARNING

- Do not operate winch with one or more cable strands kinked or broken. Failure to comply may result in severe injury to personnel or death.
- Do not operate winch with less than eight turns of wire rope on drum. Failure to comply may result in severe injury to personnel.

- 6 While operator is holding winch control lever (3) in OUT position, hand pull wire rope to object to be winched and attach.

WARNING

Do no pull in load with winch shift lever in high speed. Failure to comply may result in severe injury to personnel.

- 7 Place winch shift lever (1) in LOW (handle up).

WARNING

Stand clear of wire rope. Should wire rope break or snap loose, severe injury to personnel or death may result.

- 8 Move winch control lever (3) to IN position and winch load to desired location.
 9 Remove wire rope from load.

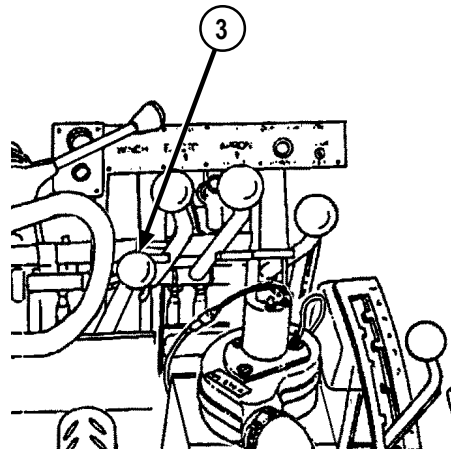
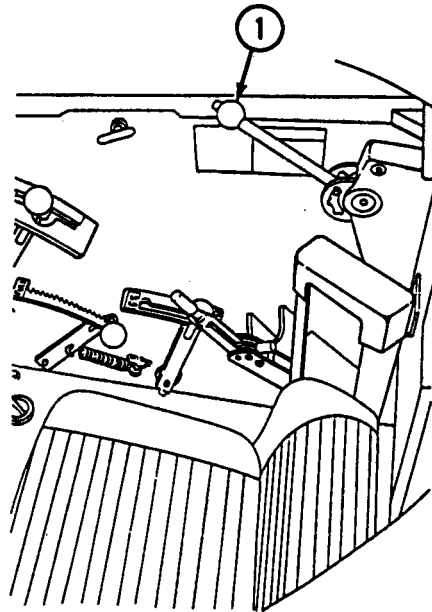

WINCH OPERATION — CONTINUED

CAUTION

The wire rope must be tightly wrapped to prevent damage to underwraps. If loosely wrapped, the wire rope top wrap pulls through the lower wrap and crushes or kinks it.

Note

If a lighter vehicle is available, use step 10 to pay in wire rope. If a lighter vehicle IS NOT available, use step 11 to pay in wire rope.

10 To pay in wire rope when a lighter vehicle is available:

- Stretch wire rope out and attach to a lighter vehicle.
- Set parking brake (1) of M9.
- Release the parking brake of the lighter vehicle and place its transmission in N (neutral).
- Place winch shift lever (2) in LOW (handle up),
- Operate winch control lever (3) to pay in wire rope.

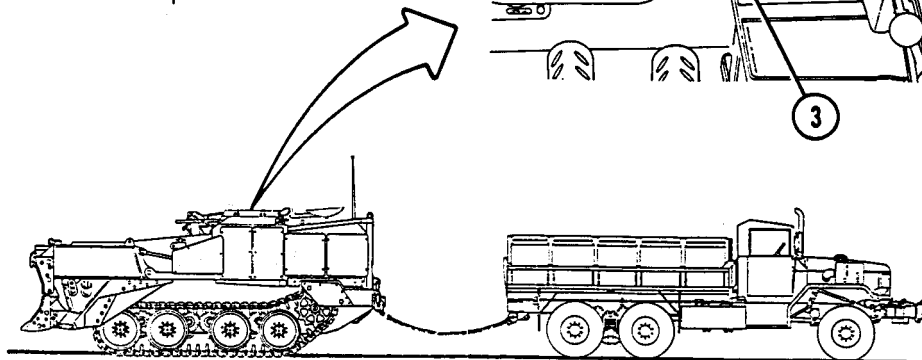
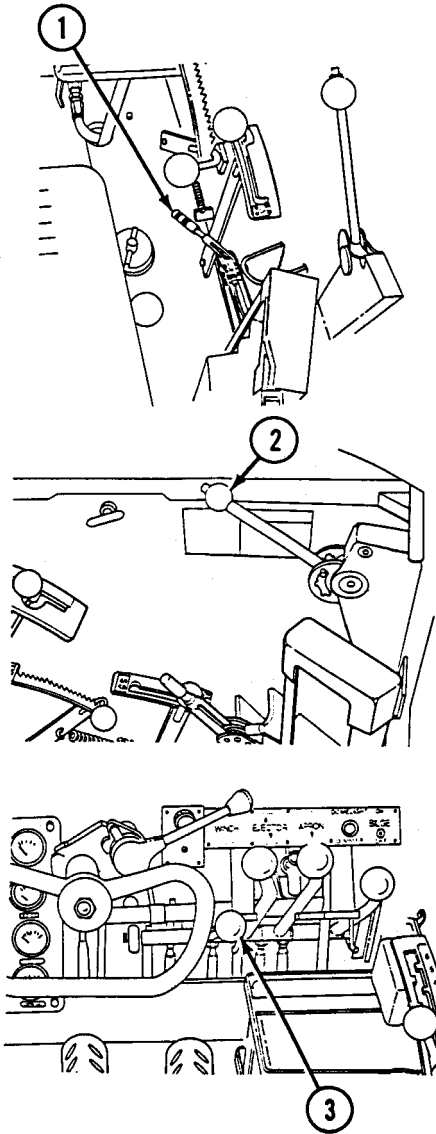

11 To pay in wire rope when a lighter vehicle IS NOT available:

- Stretch wire rope out and attach to a suitable anchor (tree, another heavy vehicle, etc.).
- Place transmission shift lever (4) in N (neutral) and steer selector lever (5) in GS.
- Place winch shift lever (2) in LOW (handle up).
- Operate winch control lever (3) to pay in wire rope and pull M9 backwards as wire rope feeds onto drum.

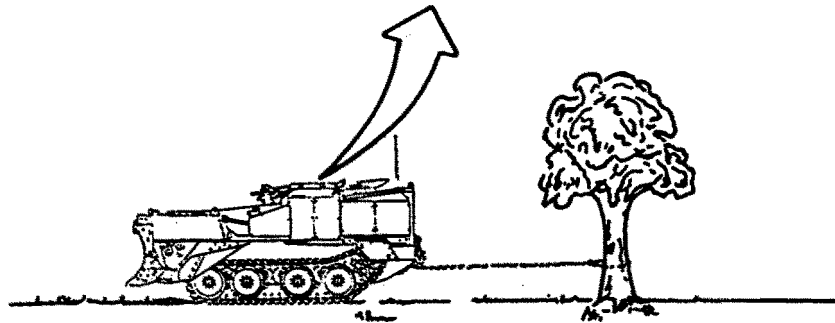
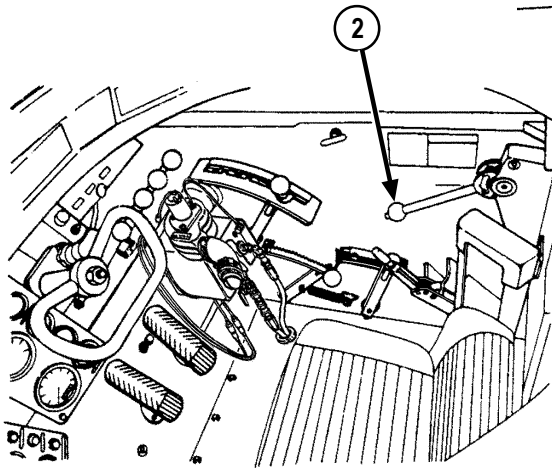
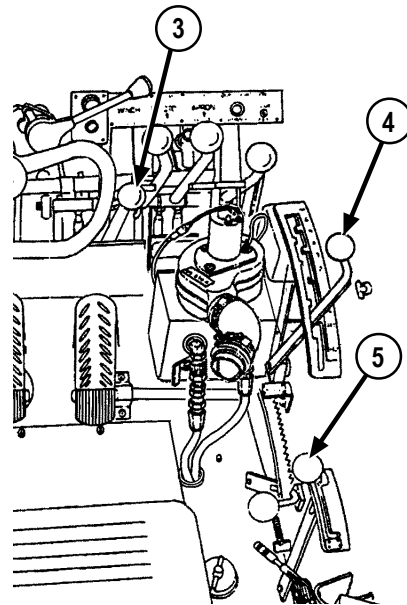

TM 5-2350-262-10

WINCH OPERATION

- 12 When all but about 3 ft (91 cm) of wire rope is on drum, disconnect wire rope hook (1) from lighter vehicle or anchor. Attach wire rope hook (1) to hull bracket (2) and pay in wire rope until slack is removed from wire rope. Engage winch stop (3) to winch control lever (4).
- 13 Place winch shift lever (5) in LOW (handle up), making sure lever is firmly seated in the low range detent (6) of the shift control assembly. This will prevent wire rope pay out when winch is not in use.
- 14 At earliest opportunity, clean and lubricate wire rope in accordance with Appendix F.

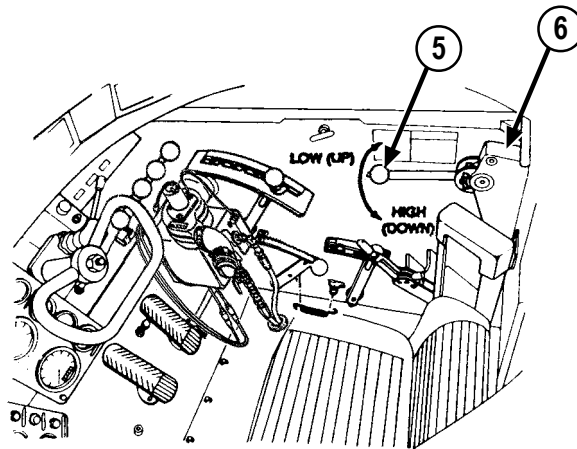
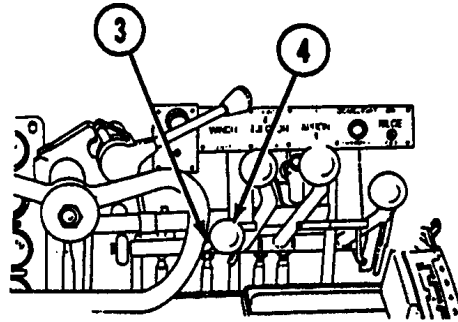
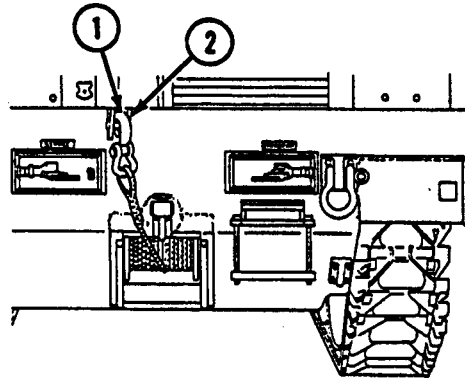

STARTING THE ENGINE USING AUXILIARY SOURCE

1 Service batteries before slave starting vehicle (p 3-18).

2 Position slave vehicle (1) behind receiving vehicle (2) so that slave receptacles (3) are adjacent.

3 Make sure MASTER SWITCH, IGNITION switch, and all accessory switches in receiving vehicle are OFF.

4 Start engine in slave vehicle (1) and run engine at 1,000 to 1,200 rpm.

5 Remove caps from slave receptacles (3) and connect slave cable (4).

6 Start engine in receiving vehicle (p 2-37). If engine does not start, then troubleshoot (p 3-2).

7 Disconnect slave cable (4) and install caps on slave receptacles (3).

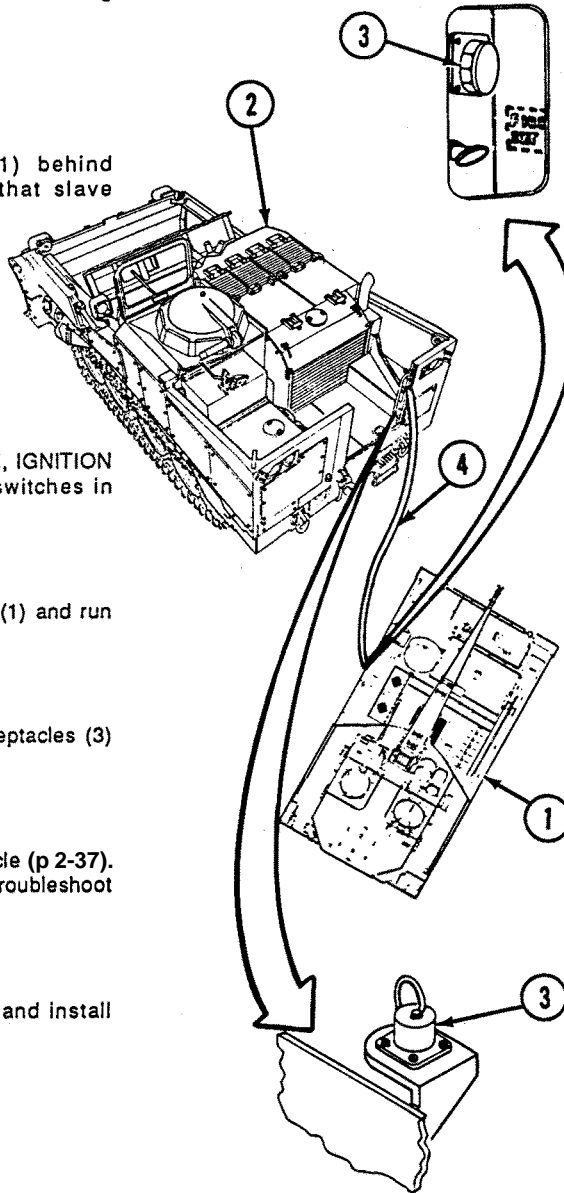

OPERATION OF AUXILIARY EQUIPMENT

This section contains operating instructions for auxiliary equipment, that is part of the vehicle, which the operator must know how to operate.

PORTABLE FIRE EXTINGUISHER OPERATION

The portable fire extinguisher is outside the driver's compartment on the rear driver's compartment wall.

- 1 Pull latch (1) and lift fire extinguisher from bracket (2).

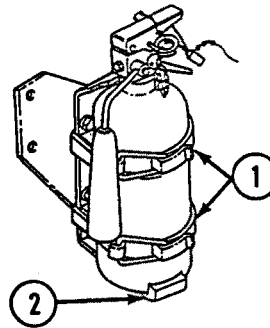

- 2 Break safety wire (3) and pull safety pin (4).

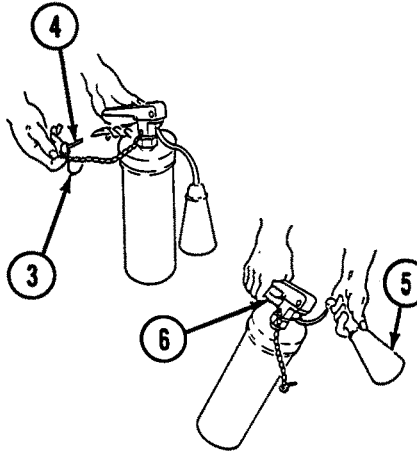

WARNING

Do not breathe fire extinguisher vapors. Fire extinguisher vapors will cause fainting if inhaled.

- 3 Swing nozzle (5) up to horizontal, aim at base of flames, and squeeze trigger (6).

OPERATION OF AUXILIARY EQUIPMENT - CONTINUED

FIXED FIRE EXTINGUISHER OPERATION

- 1 Fixed fire extinguisher handle (1) is located in drivers compartment on the right side, above and to the rear of the transmission shift lever, and handle (2) is located on the right outside of vehicle.

WARNING
 Do not breathe fire extinguisher vapors. Fire extinguisher vapors will cause fainting if inhaled.

- 2 In case of a fire, shut off engine by turning IGNITION switch (3) to OFF, MASTER SWITCH (4) to OFF, and pull hard on handle (1) or (2).

- 3 If in vehicle, disarm with portable fire extinguisher.

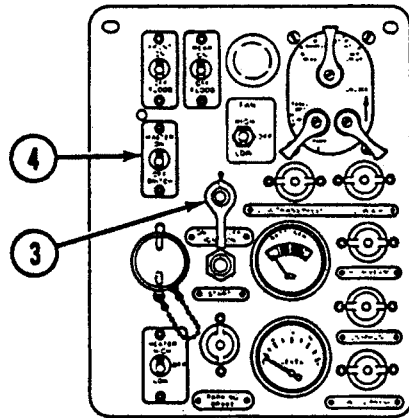
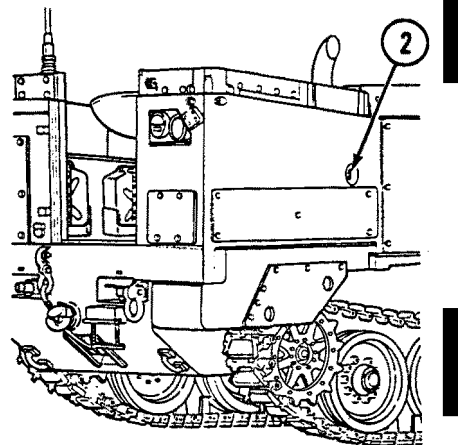
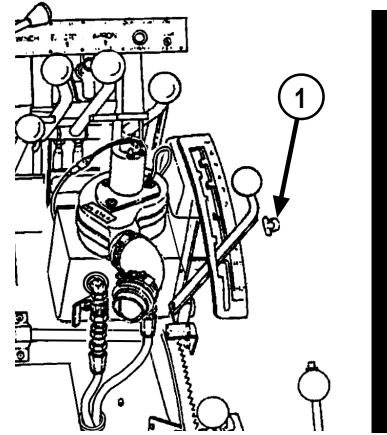

OPERATION OF AUXILIARY EQUIPMENT - CONTINUED

DRIVER'S HEATER OPERATION

- 1 Open control valve (1) (handle up) to allow coolant flow through heater (2).
- 2 Temperature is controlled by HEATER switch (3). Select blower setting for most comfortable setting.

Deleted

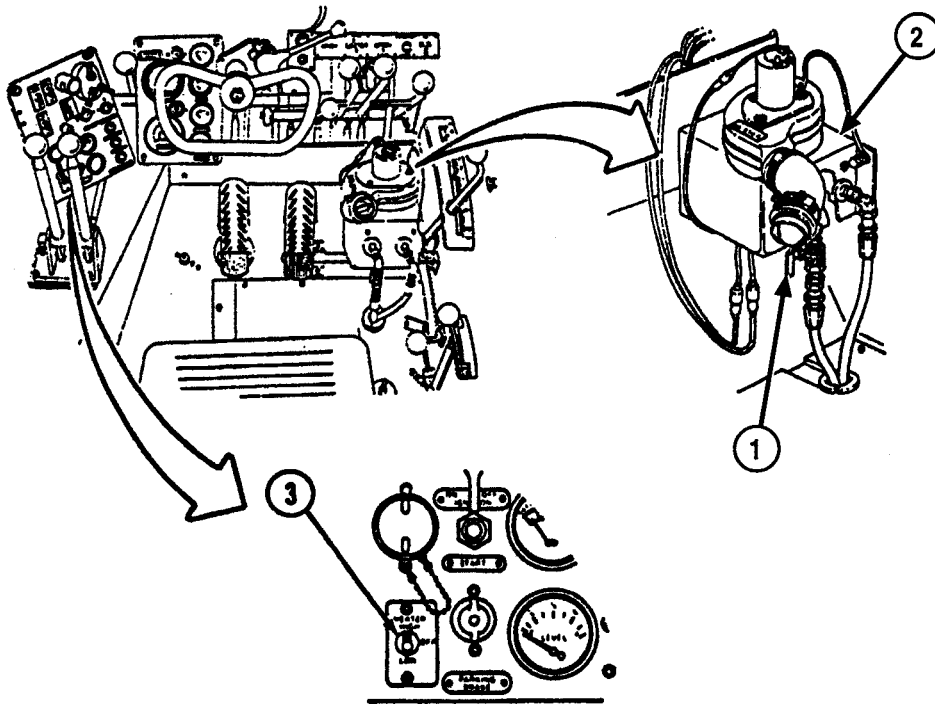

COMMUNICATION SYSTEM OPERATION

The radio set is located behind the driver above the fuel tank. It is operated directly, with access through the rear cab wall. (For a more detailed description of the communication system, refer to TM 11-5820-890-10-3 or TM 11-5820-498-12).

WARNING

- Antenna adds an extra 9-1/2 ft (2.9 m) to the vehicle clearance.
- Always check the area to be worked in for powerlines, their height, and power poles or towers.
- Do not stop your vehicle under powerlines.
- If you are not sure that the antenna will clear a powerline, stop before you get too close to the powerline and either tie down the antenna or remove antenna sections to make sure you can proceed safely.
- Try to maintain mobile communications with antenna tied down.
- Make sure antenna cap is securely taped on the end of the antenna.
- Do not lean against or touch antenna while transmitter is on.
- Failure to comply with any of the above may result in damage to equipment or injury to personnel.

OPERATION OF AUXILIARY EQUIPMENT - CONTINUED

COMMUNICATION SYSTEM OPERATION - CONTINUED

Note

For complete operating instructions, refer to TM 11-5820-890-3 or TM 11-5820-498-12.

- 1 Set vehicle MASTER SWITCH (1) to ON.
- 2 Set switch (2) of radio (3) to ON.
- 3 Plug headset leads (4) into jacks (5) and (6) of radio (3). Observe color codes of leads (4) and jacks (5) and (6).
- 4 Adjust volume control knob (7) of radio (3) for a comfortable audio level in headset.

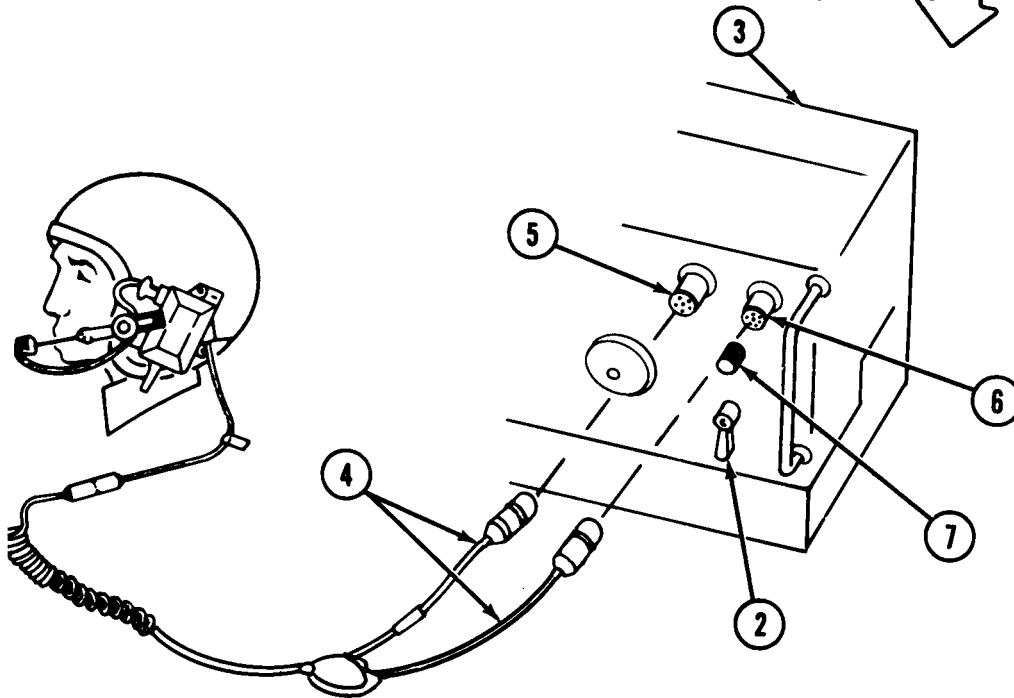
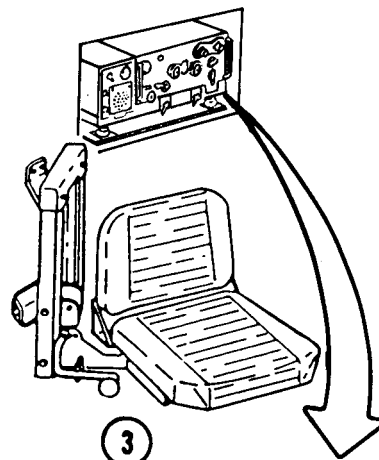
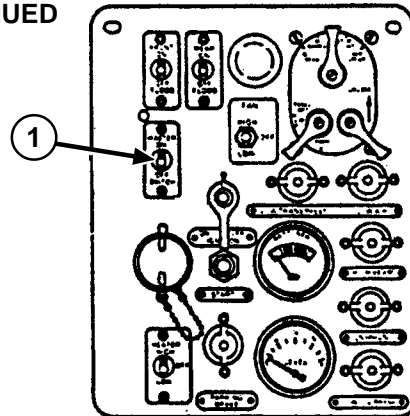

OPERATION OF AUXILIARY EQUIPMENT — CONTINUED

NBC SYSTEM

WARNING

- The NBC system of the M9 ACE, or of the MCS unit (if installed), will not protect against carbon monoxide. Failure to take precaution may result in severe injury to personnel or death.
- The NBC protection filters of the M9 ACE, or of the MCS unit (if installed), use a type of carbon that contains chromium VI. This is a known carcinogen if inhaled or swallowed. Damaged or unusable filters are classified as hazardous waste.
 - Do not throw away damaged or unusable filters as trash.
 - Turn in damaged or unusable filters to your hazardous waste management office or Defense Reutilization and Marketing Office (DRMO).

Filters are completely safe to handle and use if they are not damaged in such a way that carbon leaks from them. If carbon does leak, use protection such as a dust respirator to cover nose and mouth and put carbon in a container such as a self-sealing plastic bag; turn it in to hazardous waste management office or DRMO. Disposal of hazardous waste is restricted by law. Violation is subject to criminal penalties.

- DS2 is combustible. DS2 can also severely burn the skin, cause blindness, or deteriorate the battle dress and chemical protective overgarments. Do not use DS2 near an open flame, in confined spaces, or allow it to touch skin or clothing. Personnel handling DS2 must wear protective clothing and eye protection.

The M9 is equipped with a gas-particulate filter system to protect the operator from toxic gases and other extreme conditions. The major components of this system are:

- Gas-particulate Filter Unit, M2A2
- Air Heater, M3
- Chemical-Biological Mask, M25A1

Protective clothing and decontamination devices are also available. For a complete listing of these items, refer to Appendix C.

The M13 decontaminating apparatus is carried on the M9. For proper decontamination procedures, refer to FM 3-5.

The gas-particulate filter unit (1) is located at the left of the driver's seat.

The air heater (2) and the NBC control (3) (AIR PURIFIER SWITCH) are located on the left wall of the driver's compartment.

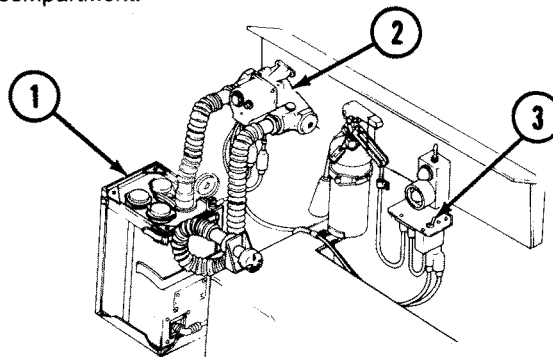

OPERATION OF AUXILIARY EQUIPMENT — CONTINUED

NBC SYSTEM OPERATION

1 Check that hose assembly (1) is securely attached to the gas-particulate filter unit (2) and the air heater (3).

2 Check that hose assembly (4) is securely attached to the air heater (3) and the connector (5).

3 Check that electrical connector (6) is securely attached to the gas-particulate filter unit (2) and that three electrical leads (7) of the air heater (3) are securely connected.

4 Check that the three unused quick-disconnect outlets (8) of the gas-particulate filter unit (2) are covered with three air flow control caps (9).

5 Put on and adjust the protective mask (10) (TM 3-4240-280-10).

6 Turn vehicle MASTER SWITCH (11) to ON.

7 Slide the spring clip (12) off the air intake holes in the gas-particulate filter unit (2) until the openings are uncovered.

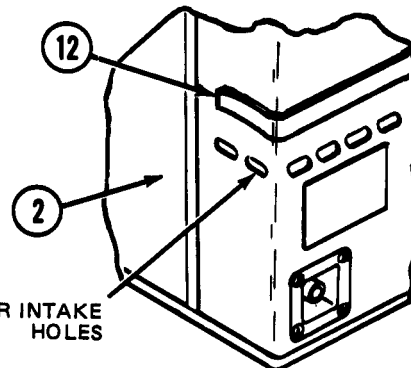
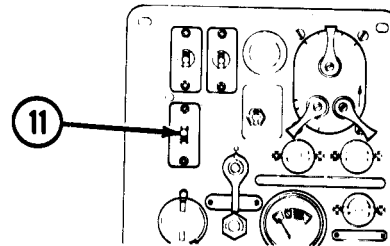
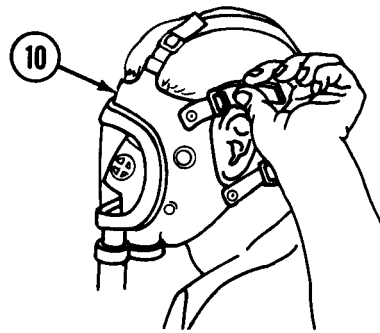
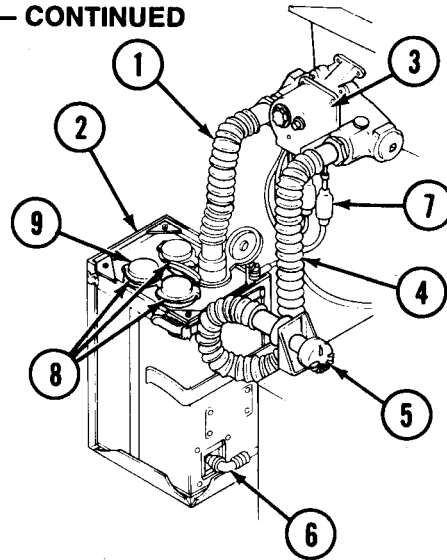

OPERATION OF AUXILIARY EQUIPMENT — CONTINUED

NBC SYSTEM OPERATION — CONTINUED

- 8 Turn the AIR PURIFIER SWITCH (13) to ON.

- 9 Disconnect hose assembly (4) from connector (5) and connect to canister (14) of protective mask (10).

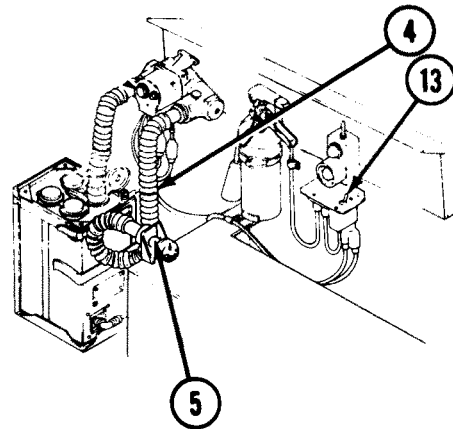

Note

It is normal for the air heater light to go on and off after it has reached operating temperatures.

- 10 If air to be breathed is 15°F (-9°C) or lower, turn on air heater (3). Turn air control knob (15) clockwise until indicator light (16) comes on. To decrease temperature, turn air control knob (15) counterclockwise.

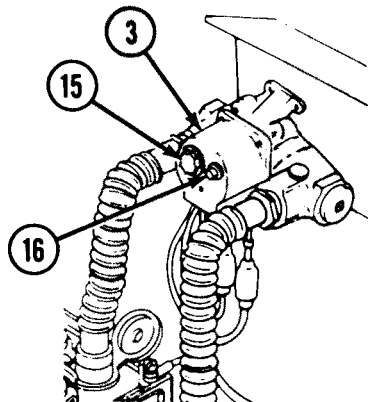
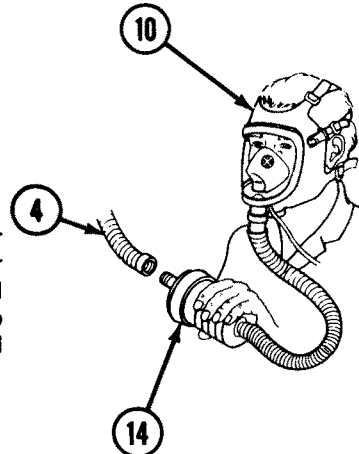

OPERATION OF AUXILIARY EQUIPMENT — CONTINUED

NBC SYSTEM OPERATION — CONTINUED

- 11 Record the duration of any chemical attack and the type of agent used.
- 12 Compute the remaining protective capability of the filter unit. Notify unit maintenance when 100 replacement units have been used.

GAS FILTER REPLACEMENT UNITS

Type of attack					
Duration of attack (min.)	Ground delivered nerve agents (units used)	Each air delivered nerve agent attack and all blister agent attacks except CX (units used)	CK (units used)	CX and all other agents including unidentified agents (units used)	
2	1/2	1	10	6	
4	1	2	20	12	
6	1-1/2	3	30	18	
8	2	4	40	24	
10	2-1/2	5	50	30	
12	3	6	60	36	
14	3-1/2	7	70	42	
16	4	8	80	48	
18	4-1/2	9	90	54	
20	5	10	100	60	

An attack lasting less than 2 minutes is considered to have a duration of 2 minutes. An attack lasting longer than 2 minutes, but less than 4 minutes, is considered to have a duration of 4 minutes. Similar consideration is given to attacks up to 20 minutes.

To calculate the number of units used in an attack longer than 20 minutes, the following formula may be used: multiply the duration (number of minutes) by the number of units shown on line 1 of the appropriate attack column and divide by 2. For example, a filter exposed to a 30-minute air-delivered nerve agent attack would use 15 replacement units, as follows:

$$\frac{30 \text{ minutes} \times 1 \text{ unit}}{2} = 15 \text{ units}$$

CAUTION

Turn off air heater before turning off the air purifier to avoid damage to air heater.

- 13 When the NBC system is no longer required, remove protective mask (1), disconnect hose assembly (2) from canister (3), turn air control knob (4) of air heater (5) fully counterclockwise, turn AIR PURIFIER SWITCH (6) to OFF, and connect hose assembly (2) to connector (7).

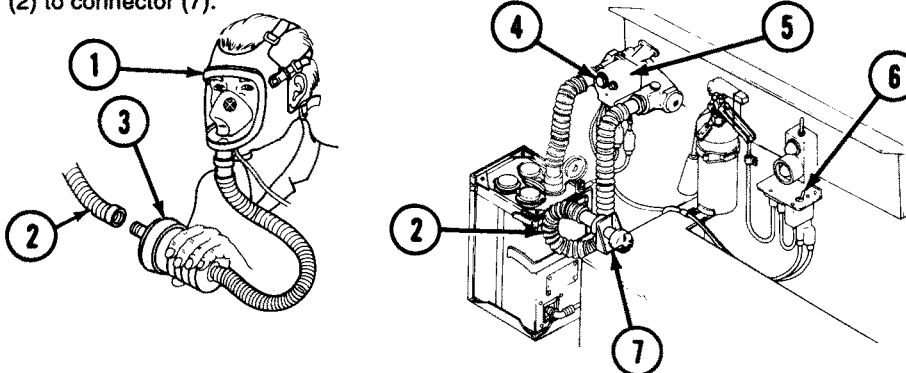

OPERATION OF AUXILIARY EQUIPMENT — CONTINUED**MICROCLIMATIC COOLING SYSTEM (MCS)****WARNING**

- The NBC protection filters of the M9 ACE, or of the MCS unit (if installed), use a type of carbon that contains chromium VI. This is a known carcinogen if inhaled or swallowed. Damaged or unusable filters are classified as hazardous waste.
 - Do not throw away damaged or unusable filters as trash.
 - Turn in damaged or unusable filters to your hazardous waste management office or Defense Reutilization and Marketing Office (DRMO).

Filters are completely safe to handle and use if they are not damaged in such a way that carbon leaks from them. If carbon does leak, use protection such as a dust respirator to cover nose and mouth and put carbon in a container such as a self-sealing plastic bag; turn in to hazardous waste management office or DRMO. Disposal of hazardous waste is restricted by law. Violation is subject to criminal penalties.

- NBC contaminated filters can only be handled and disposed of by trained personnel. Personnel must use protective clothing (FM 3-4) and follow appropriate decontamination procedures (FM 3-5). Follow unit SOP for final disposal of contaminated filters.

On M9s equipped with the MCS unit, the vehicle's existing NBC air heater and air purifier are removed, and NBC protection is provided by the MCS unit's own NBC system. The MCS unit is mounted above the vehicle's fuel tank and covered with an armor enclosure. The MCS unit is operated from a remote control box, located to the left of the driver's seat. The major components and requirements for use of this system are:

- MCS Unit
- EMI Box
- Control Box
- M200 Amp Alternator
- Chemical-Biological Mask, M25A1
- MCS Vest

OPERATION OF AUXILIARY EQUIPMENT — CONTINUED

MCS OPERATION

- 1 Connect air hose (1) to wye connector (2).
- 2 Put on MOPP gear and adjust the MCS vest (3) and protective mask (4) (TM 3-4240-280-10).
- 3 Disconnect cap (5) from air duct socket (6) and connect hose (7) to air duct socket (6).
- 4 Connect MCS vest (3) to wye connector (2).
- 5 Turn vehicle MASTER switch (8) to ON.
- 6 Perform checkout procedure (steps 7-10).

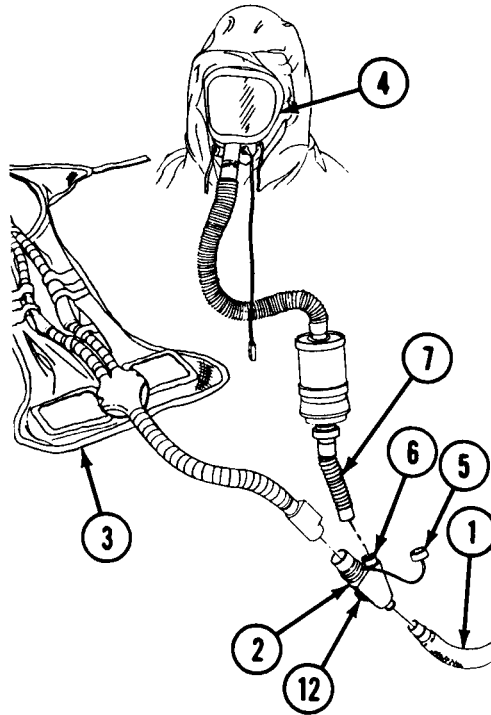

Note

Steps 7-10 shall be performed before every mission in which the use of the MCS is anticipated and following any maintenance action.

- 7 On MCS control panel (9), turn the mode selector switch (10) to COOL and the temperature control switch (11) to OFF.
- 8 Turn valve (12) to open position. Verify the delivery of cool air. Cooled air from the MCS air outlet can be felt in five to ten minutes. Use valve (12) to adjust air flow.
- 9 Turn the mode selector switch (10) to HEAT and the temperature control switch (11) to WARM. Warm air can be felt in five to ten minutes.
- 10 Verify that the MCS FAULT indicator (13) is operable by pressing TEST button (14) and ensuring FAULT indicator (13) does not light during checks.

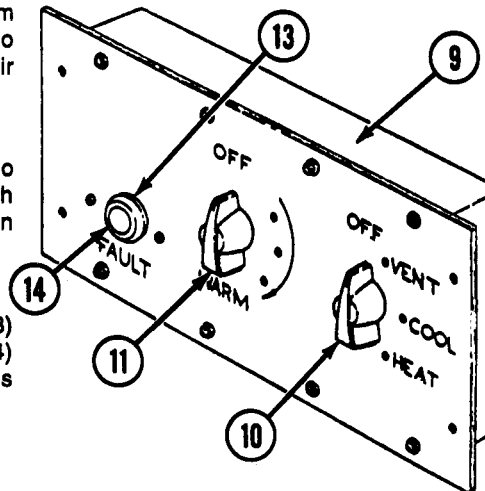
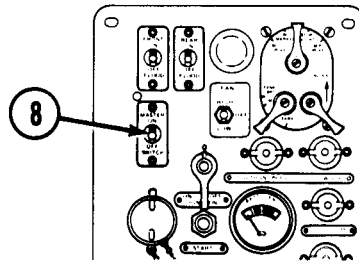

OPERATION OF AUXILIARY EQUIPMENT — CONTINUED

MCS OPERATION — CONTINUED

- 11 If the MCS unit will not be used, position the mode selector switch (10) to OFF (15).
- 12 Use the VENT mode (16) for any ambient temperature condition. Temperature control is accomplished by adjusting the temperature control switch (11).

Note

Using the COOL mode in temperatures below 45°F (7°C) will cause the MCS to shut down to prevent equipment damage.

- 13 The COOL mode (17) is effective from ambient temperatures of 45°F to 150°F (7°C to 66°C).
- 14 The HEAT mode (18) is available at all ambient conditions and heating capability is provided in steps by the temperature control switch (11).

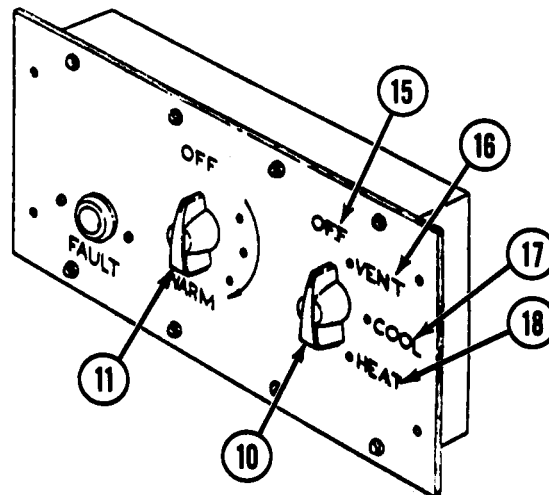

OPERATION OF AUXILIARY EQUIPMENT — CONTINUED

NIGHT VISION GOGGLES OPERATION

WARNING

Make sure rotary switch is OFF before removing or installing battery. Failure to comply may result in severe injury to personnel.

CAUTION

- This equipment is a precision electro-optical instrument and must be handled carefully.
- Keep caps on the objective and eyepiece lens at all times when not in use.
- Operate the goggles under night-time conditions only.

Note

For a more detailed description of night vision goggles operation, refer to TM 11-5855-238-10.

- 1 Remove night vision goggles (1) from carrying case.
- 2 Turn rotary switch (2) OFF.

CAUTION

Battery (BA-16567/U) contains mercury which is harmful to the environment. Do not discard batteries. Turn them in to your supply point.

- 3 Remove battery (BA-16567/U) (3) from storage and inspect it for defects. Check for bulging sides or a bulging positive (+) terminal. Do not attempt to install a defective battery.
- 4 Unscrew battery cap (4), install battery (3), and screw battery cap (4) back on night vision goggles (1).

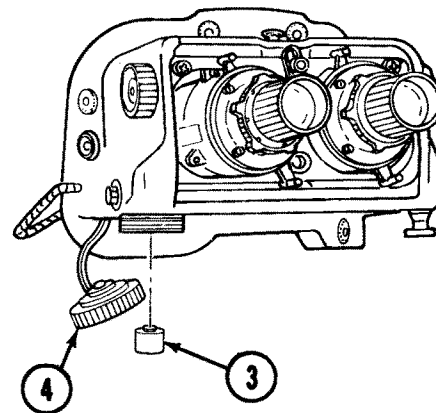
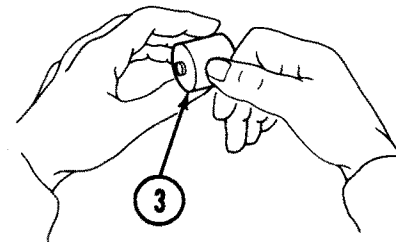
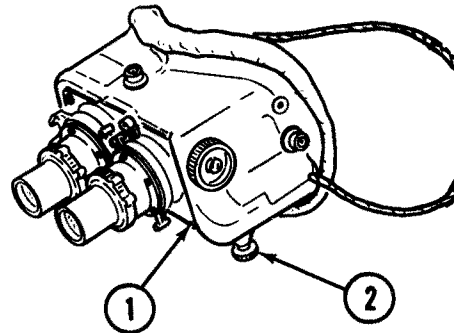

OPERATION OF AUXILIARY EQUIPMENT — CONTINUED

NIGHT VISION GOGGLES OPERATION — CONTINUED

- 5 Snap headstrap (1) to night vision goggles (2), making sure all straps are extended to their maximum lengths.

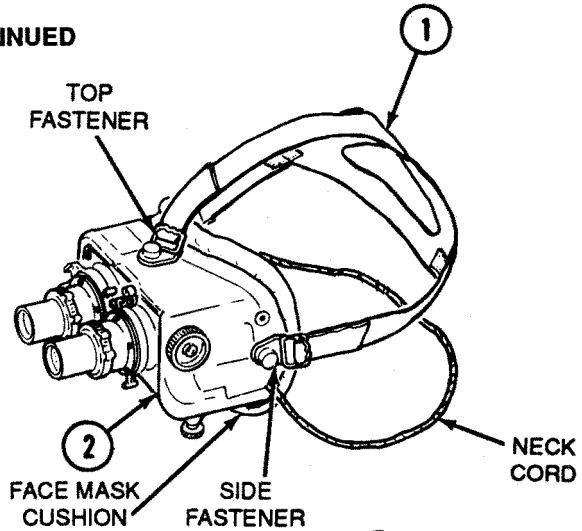

- 6 Remove two eyepiece lens caps (3) from night vision goggles (2).

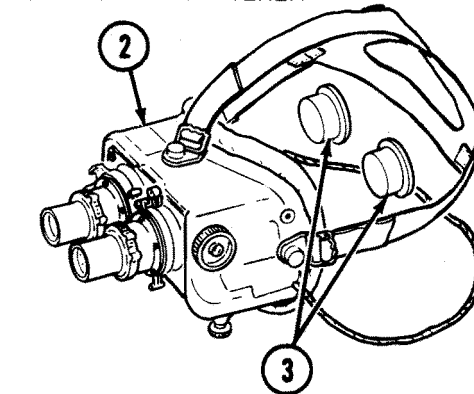

- 7 Bend your head so that you are facing the ground.

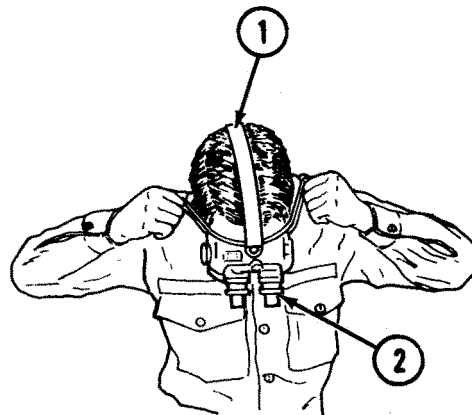

- 8 Place headstrap (1) on your head, grasp headstrap horizontal band adjustment with both hands and slowly pull until face mask cushion just touches your face. Continue pulling until night vision goggles (2) feel snug.

OPERATION OF AUXILIARY EQUIPMENT — CONTINUED

NIGHT VISION GOGGLES OPERATION — CONTINUED

- 9 With your head still bent, grasp headstrap vertical band adjustment and pull until snug.
- 10 Lift head to normal viewing position and make final adjustments on all bands until you have a comfortable, stable fit.
- 11 Remove two objective lens caps (5).

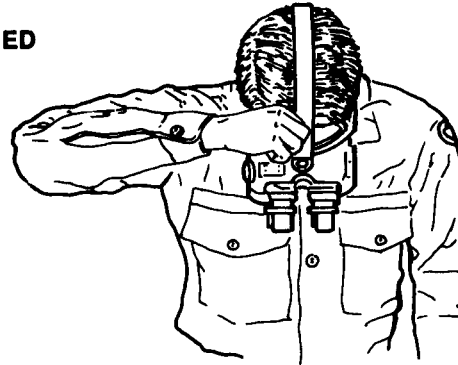

WARNING
 Extreme care should be taken to ensure that no stray light is visible from goggles when in operation (to prevent detection by the enemy). Have observer check carefully for stray light visible at edges of face mask. Failure to comply may result in injury to personnel.

- 12 Set the rotary switch (6) to ON and observe that a green glow is visible in each eyepiece (after a short delay).

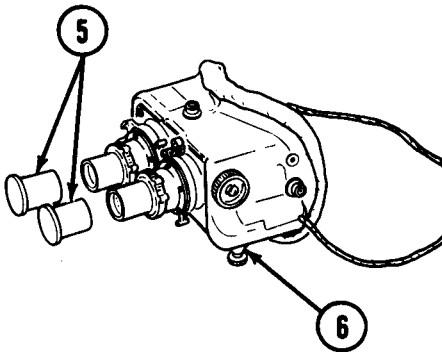

- 13 Adjust distant focus as shown below:
 - Turn two focus knobs (7) fully counter-clockwise.
 - Close left eye and adjust the right diopter ring (8) for clearest view.
 - Close right eye and adjust the left diopter ring (9) for clearest view.

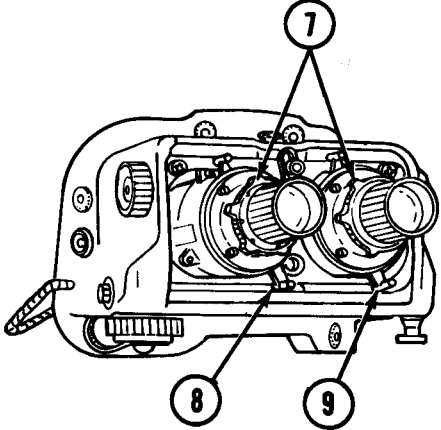

OPERATION OF AUXILIARY EQUIPMENT — CONTINUED

NIGHT VISION GOGGLES OPERATION — CONTINUED

- 14 To adjust for near focus, turn focus knobs (1) on each objective lens fully clockwise to obtain sharp focus of about 10 in. (25 cm) for reading.

WARNING

The infrared (IR) illuminator is a trouble light for conditions of extreme darkness. The light from the illuminator can be detected by the enemy using night vision devices, so use only the IR illuminator for emergencies. The purpose of the IR illuminator is for viewing within 6.6 ft (2 m). Failure to comply may result in injury to personnel.

Note

The momentary flash that is seen when the infrared (IR) illuminator is turned on is normal.

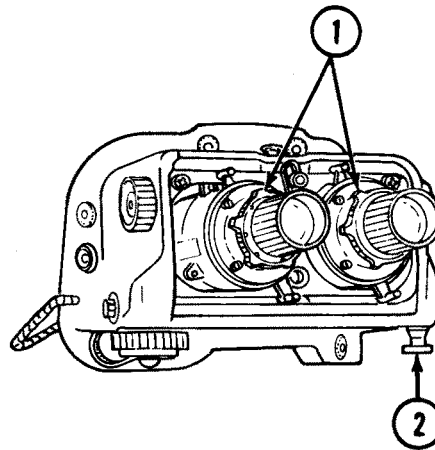

- 15 Pull and turn rotary switch (2) to IR illuminator and observe that the area immediately in front of you is lighted.

OPERATION OF AUXILIARY EQUIPMENT — CONTINUED

SMOKE GRENADES — LOADING

WARNING

Smoke grenades can explode and burn, and cause severe injuries and fires. Electricity and heat can cause smoke grenades to explode. Make sure ARM OFF switch of smoke grenade arming firing unit and vehicle MASTER SWITCH are set to OFF before loading smoke grenades. Do not place smoke grenades on or near heat or heated surface.

- 1 Set ARM OFF switch (1) of smoke grenade arming firing unit (2) and vehicle MASTER SWITCH (3) to OFF.

WARNING

Use caution when loading/unloading smoke grenade launchers. Vehicle cowling, ejector, and bowl surfaces may be slippery. Step on non-skid areas only. Failure to comply may result in serious injury to personnel.

- 2 Remove eight rubber caps (4) from eight tubes (5) of two smoke grenade dischargers (6).

Note

Load smoke grenades one at a time.

- 3 Carefully place smoke grenade (7), metal end first, into tube (5). Gently push down on smoke grenade until you hear or feel two clicks. This means that the smoke grenade is securely seated on the firing pin.
- 4 Turn each smoke grenade (7) one-half turn to ensure good electrical contact.

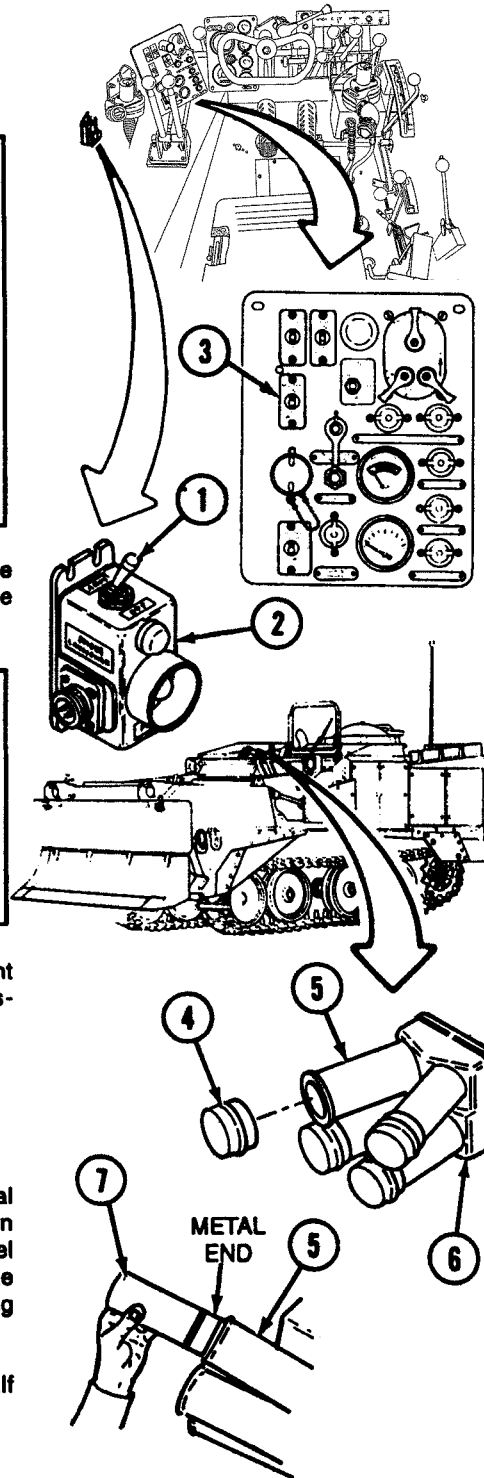

OPERATION OF AUXILIARY EQUIPMENT — CONTINUED

SMOKE GRENADES — FIRING

WARNING

- Smoke grenades can travel 410 ft (125 m) after firing. Fire smoke grenades only in authorized areas. Failure to comply may result in severe injury to personnel.
- Close driver's hatch cover before firing smoke grenades. Failure to comply may result in severe injury to personnel.

- 1 Close driver's hatch cover and point front of vehicle toward target area.
- 2 Make sure electrical connectors are tight on arming firing unit (1).
- 3 Set MASTER SWITCH (2) to ON position.
- 4 Place ARM OFF switch (3) of arming firing unit (1) in ARM position.
- 5 Fire smoke grenades by pressing FIRE switch (4) of arming firing unit (1).

WARNING

If misfired smoke grenades fire during unloading, they can cause severe injuries. NEVER place any part of your body in front of smoke grenade launchers.

Note

Smoke observed through vision blocks does not mean that all eight smoke grenades fired. Check smoke grenade launchers for misfired smoke grenades.

- 6 Look for smoke through vision blocks. If no smoke is seen, or if a misfire of one or more smoke grenades occurs, refer to EMERGENCY PROCEDURES (p 2-121).

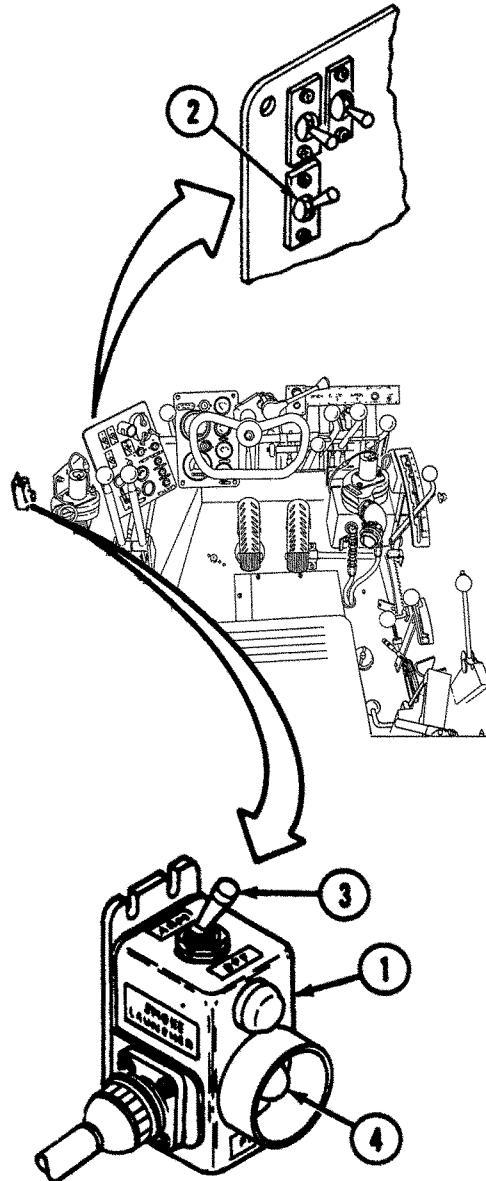
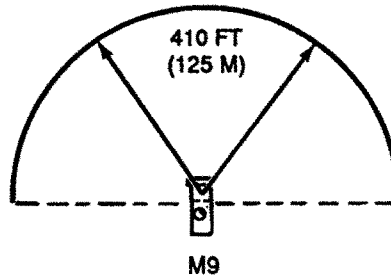

OPERATION OF AUXILIARY EQUIPMENT — CONTINUED
SMOKE GRENADE IDENTIFICATION, CARE, AND HANDLING

CARE	Keep grenades clean of dirt and grease. Do not use damaged grenades.
HANDLING	Keep grenades away from electric sparks and high heat. Do not drop or throw grenades. Do not let firing contacts be damaged.
PRESERVATION	Do not open sealed containers until you are ready to use the grenades.
PACKING	Pack unused grenades in original containers. Use those grenades first the next time you fire.
NUMBER AUTHORIZED	Eight grenades ready, 8 stowed, 16 total.

AUTHORIZED ROUND	IDENTIFICATION
Grenade, Explosive, Discharge, Smoke Screen, L8A1	Refer to illustration
or	
Grenade, Explosive, Discharge, Smoke Screen, L8A3	Refer to illustration (L8A3 designation)

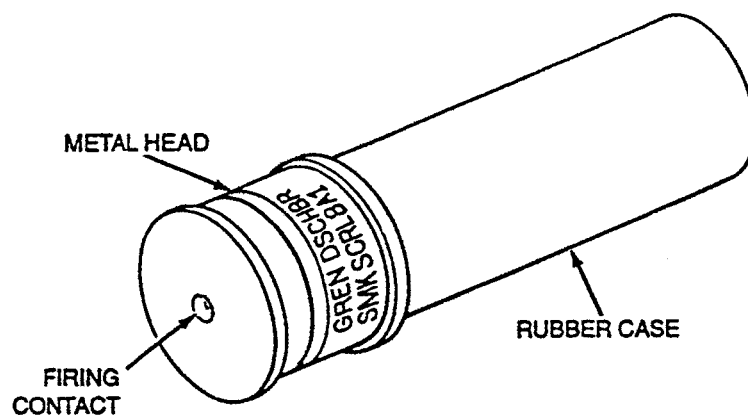

**OPERATING INSTRUCTIONS ON DECALS AND INSTRUCTION PLATES;
IDENTIFICATION PLATES**

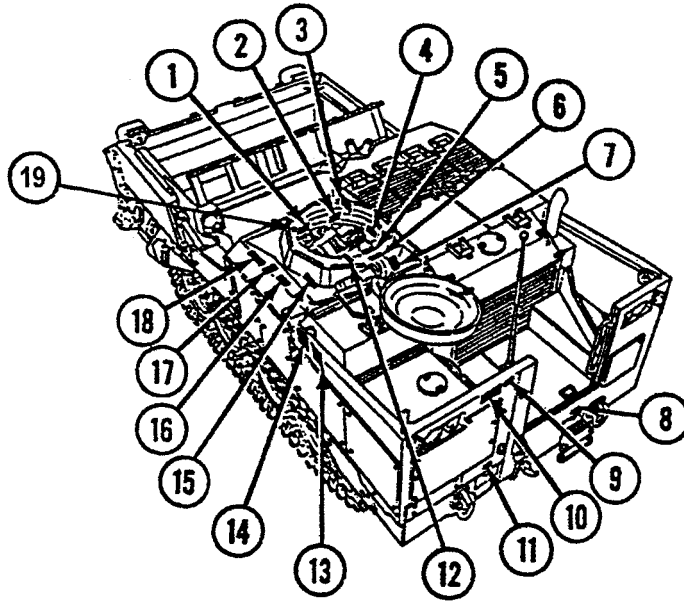

KEY	ITEM	DESCRIPTION
1	Hydraulic control levers plate	Directs hydraulic control
2	Start-aid plate	Directs start aid
3	Warning buzzer	Gives reasons for buzzer sounding
4	High intensity noise caution	Wear ear protection
5	GS plate	Directs transmission selector
6	CB plate	Directs transmission selector
7	Winch shift plate	Directs winch shifting
8	Emergency	Coupling for trailer emergency brake
9	ID plate	General data
10	Shipping data	Dimensions
11	Service	Coupling for trailer service brake
12	Transmission shift plate	Directs transmission shift lever
13	Detector kit	Placement
14	Decon kit	Placement
15	Goggles case	Placement
16	Air heater plate	Directs heater
17	Do not start vehicle when radio is on	Electrical warning
18	Suspension control levers	Directs suspension control
19	Semi-automatic track adjuster	Directs track adjuster movement

Section IV. OPERATION UNDER UNUSUAL CONDITIONS

WARNING

In situations when only single hearing protection can be worn (e.g., in MOPP conditions), the operator must be time-restricted in the M9 ACE to ensure no hearing loss (e.g., 2 hours in any 24-hour period for triple flange earplugs and 7 hours in any 24-hour period for E.A.R. foam earplugs). Failure to comply may result in severe injury to personnel.

OPERATION IN EXTREME HEAT

WARNING

Refer to Heat Stress Guidance Chart for time restrictions per heat casualty avoidance when operating in Mission Oriented Protective Posture (MOPP). Failure to follow chart may result in injury to personnel.

HEAT STRESS GUIDANCE FOR M9 ARMORED COMBAT EARTHMOVER (ACE)

Commanders and leaders at all levels should refer to (FM21-11) for further guidance concerning prevention of heat injuries. The following table, extracted from FM 21-11, should be applied as guidance for the prevention of heat injuries in acclimated individuals. These criteria are based on moderate levels of work. In situations where work is heavy or prolonged, the risk of heat injury exists at Wet-Bulb Globe Temperatures (WBGT) below 78 degrees.

HEAT CONDITION CATEGORY*	WBGT INDEX (DEGREES F)	WATER INTAKE QUARTS/HOUR	WORK/REST CYCLE-MINUTES
1	78.0-81.9°F 25.6-27.7°C	AT LEAST .50 QT AT LEAST .47 L	CONTINUOUS
2	82.0-84.9°F 27.8-29.4°C	AT LEAST .50 QT AT LEAST .47 L	50/10
3	85.0-87.9°F 29.4-31.1°C	AT LEAST 1.0 QT AT LEAST .95 L	45/15
4	88.0-89.9°F 31.1-32.2°C	AT LEAST 1.50 QT AT LEAST 1.42 L	30/30
5**	90.0°F & ABOVE 32.2°C & ABOVE	MORE THAN 2.0 QT MORE THAN 1.89 L	20/40

NOTES: * MOPP GEAR OR BODY ARMOR ADDS AT LEAST 10 DEGREES FAHRENHEIT TO THE WBGT INDEX.

** SUSPEND PHYSICAL TRAINING AND STRENUOUS ACTIVITY. IF OPERATIONAL (NONTRAINING) MISSION REQUIRES STRENUOUS ACTIVITY, ENFORCE WATER INTAKE TO MINIMIZE EXPECTED HEAT INJURIES.

OPERATION IN EXTREME HEAT — CONTINUED

Extreme heat puts an added load on the cooling system and necessitates special lubrication and battery care procedures.

- a. **Lubrication.** Refer to Appendix F for high temperature lubricants and procedures.

WARNING

Compressed air can injure you and others. Do not aim air at anyone. Do not use more pressure than 30 psi (207 kPa). Always wear goggles.

- b. **Cooling System.** Check cooling level more frequently and service cooling system (p 3-24). Avoid use of water containing alkali, salt, or other substances that cause rapid formation of rust or scale. Keep air passages of radiator clean. Remove dirt or debris by blowing compressed air, in direction opposite normal air flow, through radiator.

WARNING

Use extreme care in removing radiator cap from overheated cooling system to prevent severe burns from steam. Failure to comply may result in severe injury to personnel.

CAUTION

If engine continues to overheat at fast idle, damage to equipment may result. Stop engine and allow it to cool.

If engine becomes overheated (over 200°F (93°C)), stop vehicle and run engine at fast idle until engine cools. Then cautiously remove radiator cap and add coolant in small amounts with engine running.

- 1) Check coolant level daily. Fill radiator to proper level with coolant and/or antifreeze (p 3-24).
- 2) Check all hose connections and gaskets for leaks.
- 3) Check condition of fan belts. Have unit maintenance keep proper tension on alternator/water pump belts and fan belt.

WARNING

Do not smoke, have open flames, or make sparks when checking or servicing batteries. They can explode and injure you.

OPERATION IN EXTREME HEAT — CONTINUED

CAUTION

Direct support maintenance must adjust the alternator output voltage if the vehicle is to be operated in temperatures consistently over 90°F (32°C). Operating the vehicle in temperatures consistently above 90°F (32°C) without having the alternator properly adjusted will cause water in batteries to boil off rapidly. Failure to comply may result in damage to equipment.

- c. **Batteries.** Water in storage batteries evaporates rapidly in high temperature. Check batteries frequently, and replenish with clean distilled water (p 3-18).

Make sure direct support maintenance has adjusted alternator output voltage if vehicle is to operate in temperatures consistently above 90°F (32°C). Notify your supervisor if you are unsure.

OPERATION IN DUSTY OR SANDY AREAS

Note

Vehicle may lose traction in loose sand, especially on hilly terrain. In order to ensure traction, vehicle must be operated with bowl at least half-full of ballast, apron lowered, and ejector pushed forward to pack ballast.

Operation in dusty or sandy areas requires more frequent cleaning and servicing of filters to prevent dust entering engine, transmission, steer unit, fuel system, and hydraulic system. Dust build-up on major components increases chance of entry into internal areas and interferes with adequate cooling. Pay particular attention to the following service areas:

- a. **Lubrication.** Lubricate vehicle as specified in Appendix F, shortening service interval as required:
 - 1) Carefully clean all areas around lubrication fittings, fill ports, dipsticks, breathers, and filters before servicing or inspecting.
 - 2) Have unit maintenance service engine oil filters, fuel filters, transmission oil filter, transmission and transfer case breather, hydraulic oil filter, and hydraulic tank filter.
- b. **Cooling System.** Perform the following procedures:
 - 1) Check coolant level daily. Fill radiator to proper level with clean (distilled if available) water and/or antifreeze (p 3-24).

WARNING

Compressed air can injure you and others. Do not aim air at anyone. Do not use more pressure than 30 psi (207 kPa). Always wear goggles.

- 2) Keep radiator clean and free of dirt and debris. Remove dirt or debris by blowing compressed air in direction opposite normal air flow through radiator.
- 3) Check all hose connections and gaskets for leaks.
- 4) Check condition of fan belts. Have unit maintenance keep proper tension on alternator/water pump and fan belt.

OPERATION IN DUSTY OR SANDY AREAS — CONTINUED

c. Fuel System.

- 1) Keep fuel tank filler cap securely tightened. Wipe dirt from cap and surrounding area before filling or checking fuel level. Keep vent hole in cap open.
- 2) Check engine air cleaner daily, or more often, in extremely dusty conditions. Service air cleaner (p 3-23) as needed.

OPERATION IN RAINY OR HUMID CONDITIONS

- a. **Lubrication.** Lubricate vehicle in accordance with Appendix F. Make sure to clean grease fittings prior to lubrication.
- b. **Cooling System.** Normally, rain and high humidity tend to increase efficiency of a cooling system. However, high humidity may accelerate accumulation of dirt and debris on cooling surfaces of radiator. Keep clean and free of dirt accumulations.
- c. **Electrical System.** High humidity tends to increase corrosion of battery terminals and causes electrical leakage across top of batteries. Keep terminals well-coated with grease (GAA). Keep top and sides of batteries clean and dry.
- d. **Fuel System.** High humidity accelerates condensation of water in fuel tank. Condensation can be kept to a minimum by keeping fuel tank filled at all times when vehicle is not in operation. Fill fuel tank daily, immediately after operation. Drain any accumulated water by opening fuel shut off valve (p 2-30.3).

OPERATION IN SALT WATER AREAS

Corrosion of metal is greatly accelerated in salt water areas. Humid salt atmosphere also damages electrical components. In these areas, the following procedures must be observed:

- a. **Bare Metal Surfaces.** Keep exposed metal surfaces painted (TM 43-0139). Coat exposed wear areas, such as cylinder rods, with lubricating oil, grease, or preservative compound when not in use. Follow lubrication procedures regularly (p 3-1).
- b. **Fuel System.** Keep fuel tank full when vehicle is not in use. Service engine air cleaner when service indicator shows red.
- c. **Electrical System.** Keep electrical components clean and dry. Clean battery tops frequently. Inspect terminals, connectors, and switches frequently, and clean off moisture. Keep battery terminals well-coated with grease (GAA).

OPERATION IN EXTREME COLD

Extended operation in extremely cold temperatures requires added precautions and special lubricants. Always use the correct lubricant for the expected climate conditions (Appendix F) and keep the fuel tank filled.

If starting the engine is a problem, refer to the cold weather starting procedures (p 2-102). As cold temperatures inhibit the performance of the batteries, it may be necessary to use an auxiliary source (p 2-77) while performing the cold weather start.

Once the engine has started, it is important to maintain an engine temperature of at least 140°F (60°C). Allowing it to drop below 140°F (60°C) will cause engine wear, carbon clogging, and damage. It may be necessary to partially cover the intake or exhaust grilles.

Operation in snow requires added care and special procedures in driving the vehicle. Generally, snow limits maximum speed of vehicle and reduces maneuvering and stopping ability. Procedures for maximum safety and effectiveness when operating vehicle in snow are covered in the following paragraphs:

- a. **Preparation for Snow Operation.** Keep all exposed lubrication fittings lubricated in accordance with Appendix F. For better traction on packed snow, particularly on grades, remove all rubber pads from track shoes (p 3-28).
- b. **Operation.** Observe the following procedures when operating in snow:
 - 1) On any snow-covered surface, reduce speed and anticipate turns and stops. Avoid abrupt turns and sudden changes in speed.
 - 2) Shift transmission to a lower speed range for ascending and descending grades.
 - 3) Approach grade straight on, rather than at an angle, to reduce possible sideslip or spinout.
 - 4) Avoid abrupt turns and speed changes on grade.
 - 5) On steep downgrades, use lowest transmission speed range, and use brakes sparingly to prevent loss of control.
- c. **After-Operation Procedures.** At completion of snow operations, inspect tracks and suspension. Remove chunks of impacted snow or ice. Check for cracked or distorted track shoes. Check and adjust track tension if necessary (p 3-26). Wipe snow and ice from hydraulic cylinder rods, and coat with oil (OE) or light coating of grease (GAA). If removed, install track shoe pads (p 3-28).

OPERATION IN MUD

- a. **General.** Operation in mud requires more power than on hard ground and puts more strain and wear on suspension and drive components. The speed range is reduced substantially, and added precautions must be taken to prevent damage to drive and suspension components, and to avoid stalling.
- b. **Operation.** Before entering muddy areas, shift transmission to the desired lower range, so no shifting will be required while traversing the mud. Also, select a course that will require minimum direction change. Once mud field is entered, keep vehicle moving until it encounters solid ground again.
- c. **After-Operation Procedures.** After operation in mud, thoroughly clean vehicle and remove mud and debris from tracks, suspension, blade, and apron. Inspect tracks for damaged shoes. Lubricate as required in accordance with **Appendix F**.

OPERATION AT HIGH ALTITUDE

The vehicle is designed to operate efficiently up to a height of about 10,000 ft (3,050 m). However, because air pressure decreases with an increase in altitude, maximum available power and engine performance decrease with increased altitudes. Power will drop about 3% for every 1,000 ft (305 m) elevation increase. Keep engine air filter clean (p 3-23) for the least resistance to flow of intake air. Keep radiator and oil cooler clean for maximum dissipation of powertrain heat.

OPERATION ON SIDE SLOPES

WARNING

- The M9 must be operated within the ballast and grade requirements listed below. Failure to comply may result in a vehicle rollover, causing severe injury to personnel or death.
- If vehicle rollover is imminent, duck your head into the operator's compartment, below the vision blocks, until the vehicle comes to a complete stop. Do not attempt to look out or maintain control of vehicle. Failure to comply may result in severe injury to personnel or death.

The M9 can operate on side slopes of up to 40%. However, for operation on slopes greater than 20%, ballast must be loaded into the bowl. Refer to the chart below for ballast requirements for the various slopes.

<u>Grade of slope</u>	<u>Ballast required</u>
20% or less	No ballast
30%	4,000 lb (1,816 kg)
40%	18,000 lb (8,172 kg)

Operations on slopes can cause material to build up around tracks. This material, when compacted between track and hull, or track and track retainers, can cause the vehicle to throw a track. Periodically clean dirt and mud from tracks when operating on side slopes.

OPERATION IN GRAVEL

WARNING

Do not stand in line with drive sprockets when operating in gravel. Rocks and rock chips can be thrown out of drive sprockets with high velocity, causing severe injury to personnel.

- a. **General.** Operation in gravel causes rapid wear of suspension components. Also, flying rocks and rock chips create a hazard to personnel. The operating procedures and limitations listed in paragraph b, below, should be followed to avoid damage to the vehicle and injury to personnel.
- b. **Operation.** Observe the following procedures when operating in gravel.
 - 1) When turning the vehicle, make as wide a turn as possible. Avoid sharp turns and pivots.
 - 2) Restrict backing operations. Use reverse only when it cannot be avoided.
 - 3) Do not allow gravel to pile up more than 1/3 of the height of the apron/dozer assembly.
 - 4) Do not drive near personnel. Rocks can be thrown out of the drive sprockets with high velocity.
- c. **After-Operation Procedures.** After operating in gravel, inspect suspension components, hull, and track retainers for excessive wear and damage. Inspect cutting edges and scraper for wear or damage.

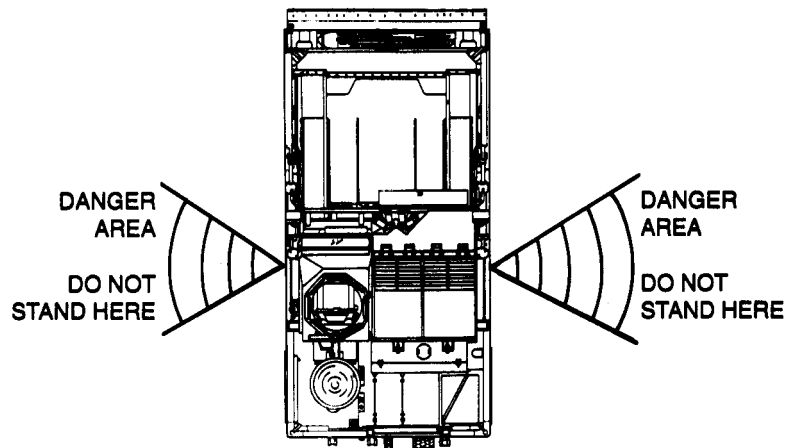

COLD WEATHER STARTING PROCEDURES

CAUTION

Severe internal engine damage can occur by using an excessive amount of cold start aid while attempting to start the engine.

Note

Use this cold start procedure for temperatures at or lower than 25°F (-3.8°C).

- 1 Turn on MASTER SWITCH (1) and IGNITION switch (2).

CAUTION

Do not crank engine for more than 20 seconds. Let starter cool for 1 or 2 minutes before pressing engine START switch.

- 2 Depress engine START switch (3) and depress and release START AID control button. Continue cranking engine for three more seconds.
- 3 If engine fails to start, wait 30 to 45 seconds, then repeat step 2.
- 4 If engine starts to stall, depress and release START AID control button.
- 5 If engine fails to start, wait 30 to 45 seconds, and repeat step 2. If engine still does not start, notify unit maintenance.

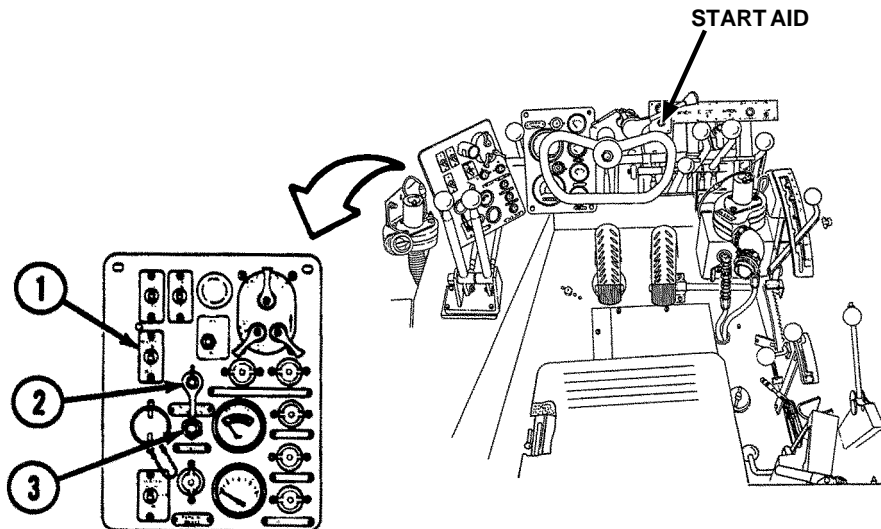

DELETED

FORDING OPERATION

WARNING

Do not try to ford when water is more than 36 in. (91 cm) deep. Failure to comply may result in damage to equipment or injury to personnel.

Note

Ensure drain valve is clear of debris and closed with a positive seal, prior to fording operation.

- 1 Start the engine (p 2-37) and allow it to warm up for 3 to 5 minutes.
- 2 Place CB/GS steer selector lever (1) in either CB or GS position.

Note

If dozing will be performed while fording, fill bowl with ballast. Place SPRUNG/UNSPRUNG control lever in UNSPRUNG.

- 3 Place SPRUNG/UNSPRUNG control lever (2) in SPRUNG position.
- 4 Place transmission shift lever (3) to 1; then shift to 2 as necessary.

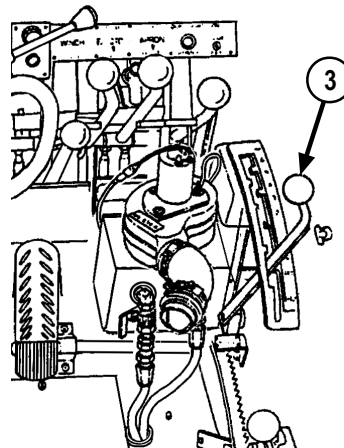
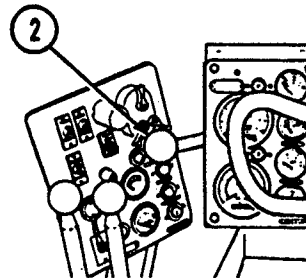
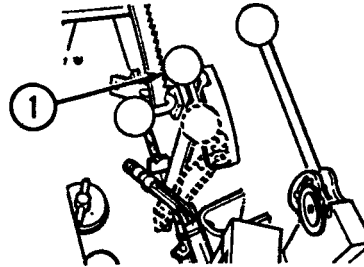

FORDING OPERATION - CONTINUED

Note

It is normal for water to leak into the bowl when fording.

- 5 Enter water at right angle to bank, and drive through water at low speed.
- 6 If opposite shore is steep, it may be necessary to shift transmission to 1 and slowly accelerate.

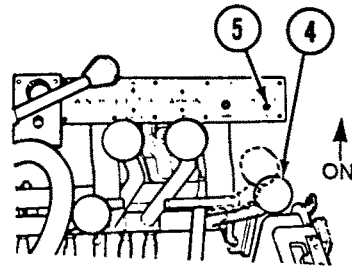

Note

Although the Bilge Pump is considered Not Mission Essential and will no longer be supported with spare and repair parts, this manual contains operational procedures For Your Information Only. Notify Unit maintenance if the bilge pump no longer operates.

Note

Engine speed must be at least 1,000 rpm for bilge pump to operate.

- 7 Push bilge pump control lever (4) to ON. Bilge pump light (5) should light.
- 8 When water in hull area has been pumped out, return bilge pump control lever (4) to OFF (pull back).
- 9 To remove water from rear of hull, lift out rear floor plates and push hull drain valve (6) to open.
- 10 If water level was above drive sprockets during fording, notify unit maintenance to check for water in both final drives; then drain and refill as necessary (Appendix F).

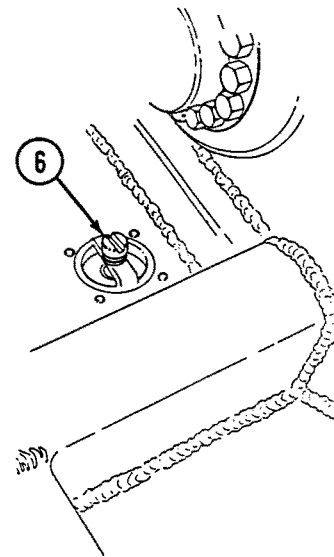

EMPTYING THE BOWL AFTER HYDRAULIC FAILURE

- 1 Attach the chain, cable, or sling from a wrecker to apron lifting eyes (1) on top of apron (2).
- 2 Fill apron cylinder with oil by moving apron control lever (3) forward, and secure in that position. Lever must be held in this forward position during the operation.

WARNING
Do not work or stand under raised apron assembly unless apron lockpins are installed. Apron assembly can drop, causing severe injury to personnel or death.

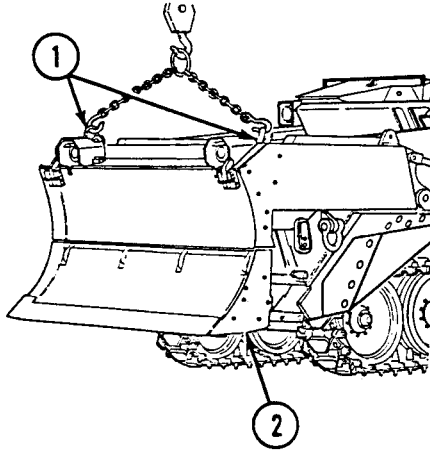

- 3 Use a wrecker or recovery vehicle with a lifting capacity of at least 10 tons (9.07 metric tons) to raise apron (2) to full up position.
- 4 Have helper install two upper apron lockpins (4) and remove chain, cable, or sling.

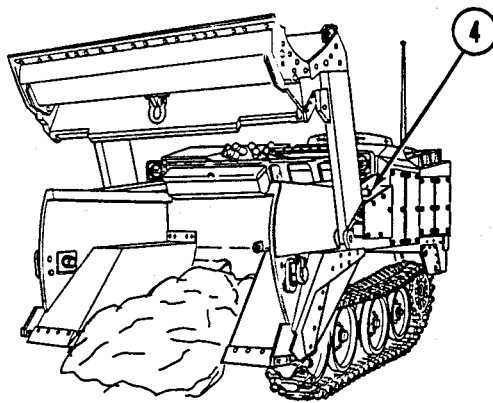
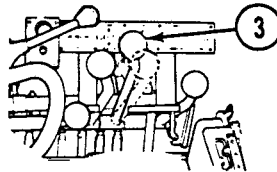

EMERGENCY PROCEDURES — CONTINUED

EMPTYING THE BOWL AFTER HYDRAULIC FAILURE — CONTINUED

5 Attach cable to lifting eye (5) of ejector (6) and a towing vehicle. Push ejector control lever (7) forward and secure in that position. Lever must be held in this forward position during the operation.

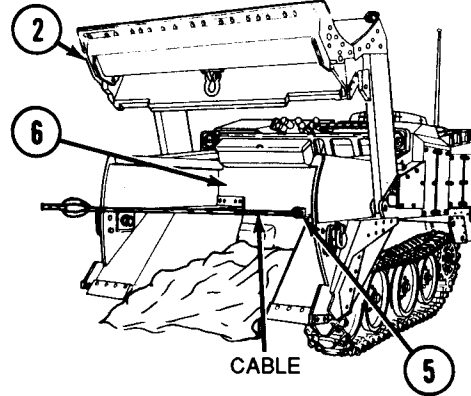

6 Use towing vehicle to pull ejector forward and empty the bowl. Disconnect cable from lifting eye (5) of ejector (6).

7 Clean dirt or gravel from front of bowl area so apron (2) can be lowered. If possible, lay blocks under blade capable of supporting weight.

8 Attach a chain or cable from wrecker or recovery vehicle to apron lifting eyes (1). Have helper remove two upper apron lockpins (4) and lower apron (2).

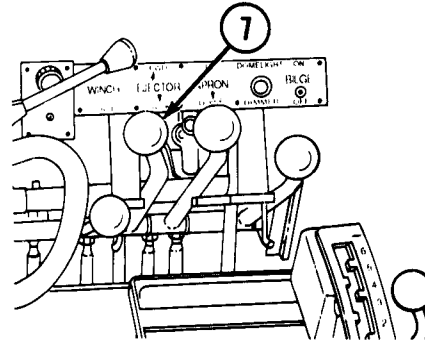

9 Install two lower apron lockpins (8), two screws (9), and disconnect cable, chain, or sling from apron lifting eyes (1).

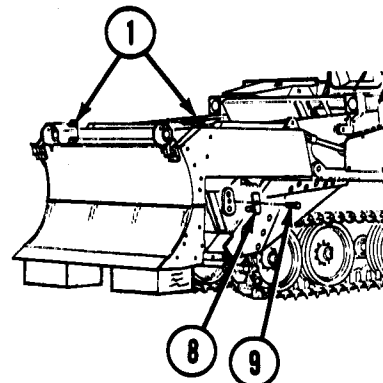
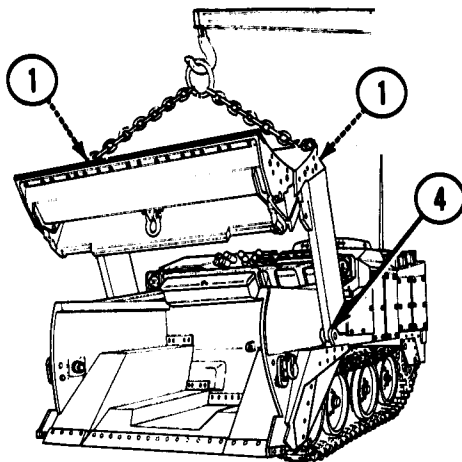

EMERGENCY PROCEDURES — CONTINUED

RAISING FRONT OF VEHICLE

- 1 Make sure apron (1) is secured to hull with two lower apron lockpins (2).
- 2 Make sure dozer blade (3) is secured to apron (1) with two dozer blade lockpins (4).
- 3 Attach a cable, chain, or sling of a wrecker or recovery vehicle with a capacity of at least 10 tons to the apron lifting eyes (5) on top of apron (1).

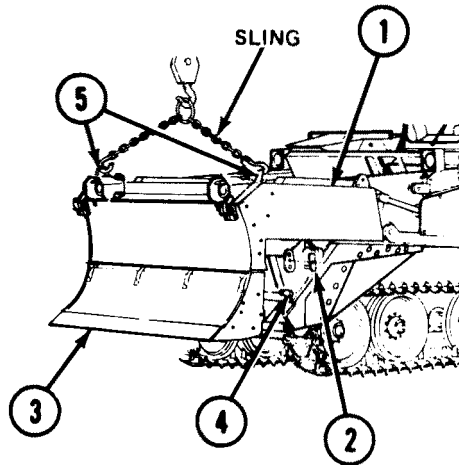

WARNING
Make sure supports will support weight of dozer blade. Failure to comply may result in severe injury to personnel or death.

- 4 Lift front of vehicle 20 in. (51 cm) off ground and install suitable support under dozer blade (3).

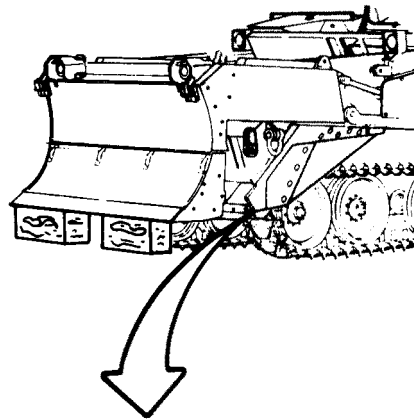

- 5 Remove bump stop access plate (6) by removing center screw (7) and four corner screws (8) from access plate (6).

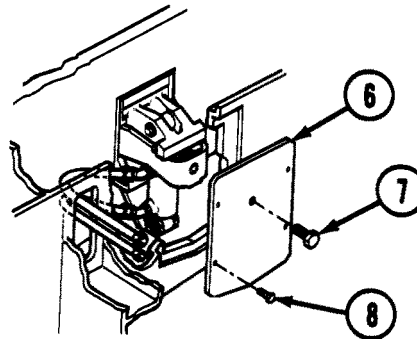

EMERGENCY PROCEDURES — CONTINUED

RAISING FRONT OF VEHICLE — CONTINUED

- 6 Place SPRUNG/UNSPRUNG control lever (9) in UNSPRUNG position.

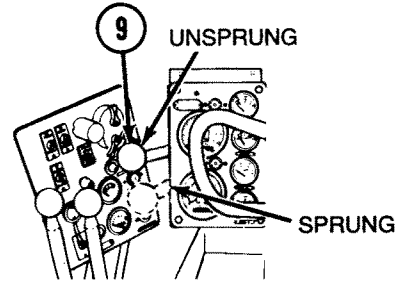

- 7 Work through access hole and use hand to push down on bump stop cylinder (10) until bump stop (11) extends out of hull.

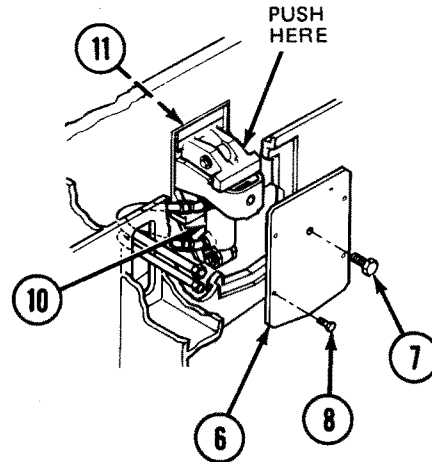

- 8 When both bump stops (11) are fully extended, return SPRUNG/UNSPRUNG control lever (9) to SPRUNG position.

- 9 Install bump stop access plate (6) with four corner screws (8) and one center screw (7). As soon as possible, have unit maintenance tighten screws.

- 10 Use wrecker or recovery vehicle to lift front of vehicle slightly. Remove support blocks from under dozer blade (3), then lower front of vehicle until it settles on bump stops. Remove cable or sling from apron lifting eyes (5).

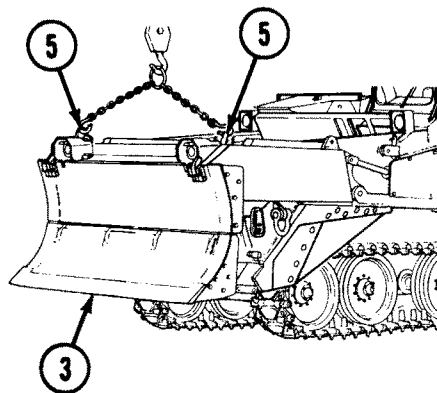

EMERGENCY PROCEDURES — CONTINUED

DISCONNECT FINAL DRIVES

CAUTION

Powertrain components can be damaged if the final drive input shafts are not disconnected from steer unit before towing vehicle.

- 1 Lift out and remove three rear floor plates (1) from rear of vehicle.
- 2 Disconnect right and left final drive fill hoses (2) from elbows (3) and (4).

Note

Both final drive input shafts are disconnected the same way. Only right side is shown here.

- 3 Remove four screws (5) and floor plate braces (6) from rear of vehicle.
- 4 Remove six screws (7), washers (8), and final drive cap (9) from final drive flange (10).
- 5 Pry up tabs on nut (11) with screwdriver.
- 6 Use spanner wrench 12355454 to loosen nut (11) and slide nut (11) toward final drive (12).

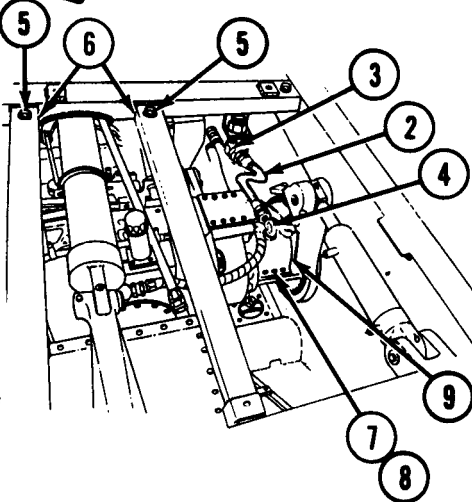
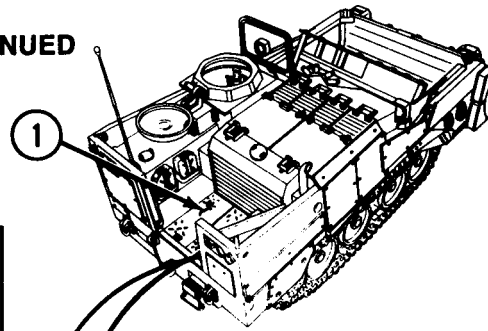

RIGHT SIDE SHOWN

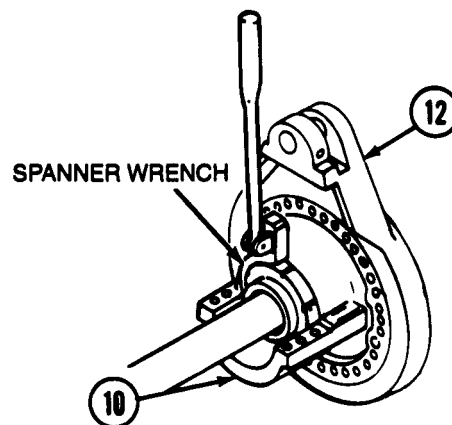
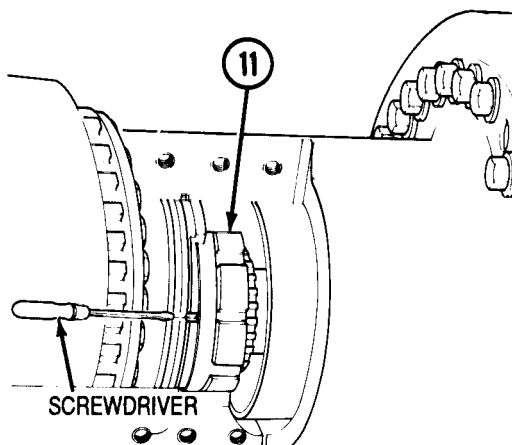

EMERGENCY PROCEDURES — CONTINUED

DISCONNECT FINAL DRIVES — CONTINUED

- 7 Separate final drive input shaft (13) from steer unit coupling (14). Push input shaft (13) into final drive (12).
- 8 Install spacer plate (15) (5365-01-186-8009) (Appendix B, item 54) in final drive flange (10) to keep input shaft (13) from hitting steer unit components.
- 9 Install final drive cap (9) on final drive flange (10) with six washers (8) and screws (7).
- 10 Connect right and left final drive fill hoses (2) to elbows (4) and (3).
- 11 Install floor plate braces (6) on rear of vehicle with four screws (5).
- 12 Install three rear floor plates (1).

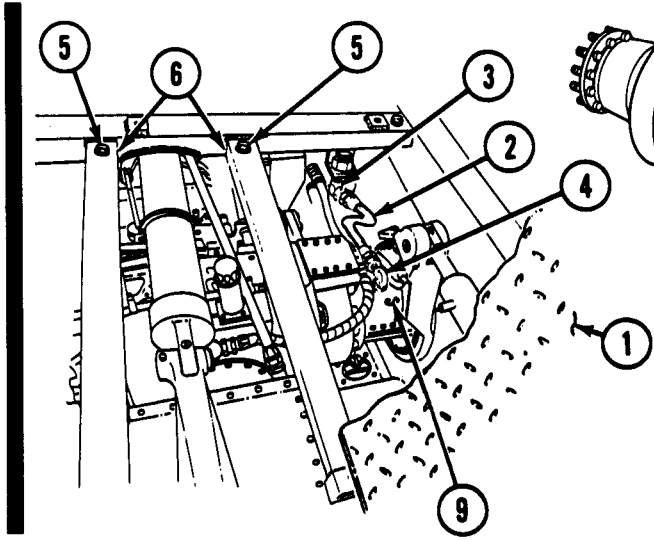
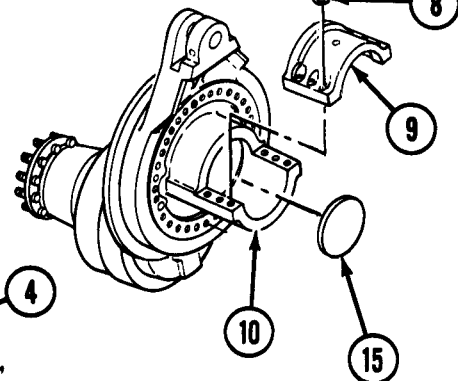
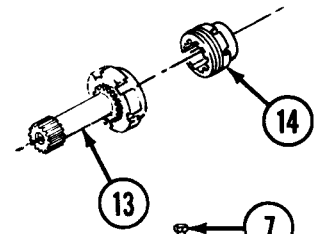
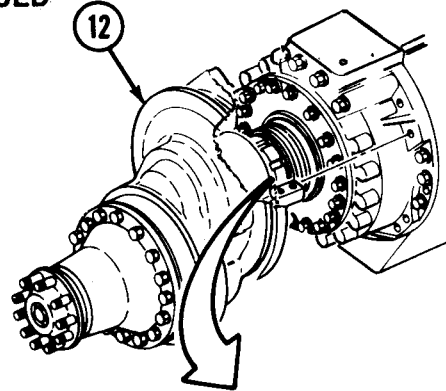

RIGHT SIDE SHOWN

EMERGENCY PROCEDURES — CONTINUED

RECOVERY OPERATIONS

CAUTION

The M9 can be damaged if correct recovery procedures are not followed. Observe the procedures listed in this section and in FM 20-22 for correct recovery procedures.

- 1 Use the tow shackles (1) at the rear of the vehicle for retrieving the M9. There are no suitable attaching points at the front of the M9.
- 2 Do not attempt to use the towing pintle (2) for retrieving the M9.
- 3 Use the lifting eyes (3) on the corners of the M9 only for lifting the vehicle.
- 4 When using the winch for self recovery, always keep the wire rope (winch cable) (4) in a line with the center line of the vehicle. For winch operations, see 2-72. For using the winch for self recovery, refer to page 2-119.

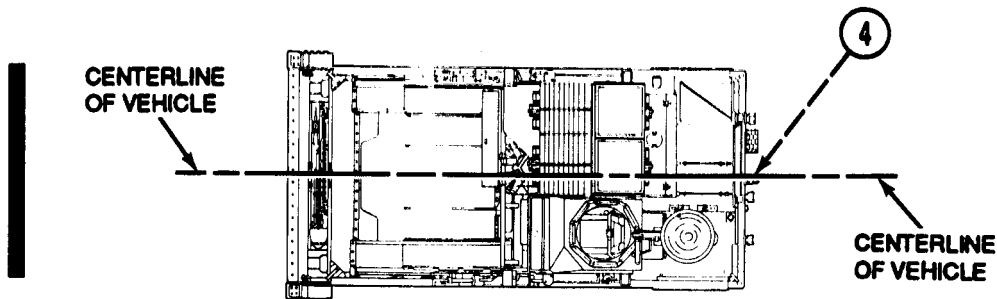
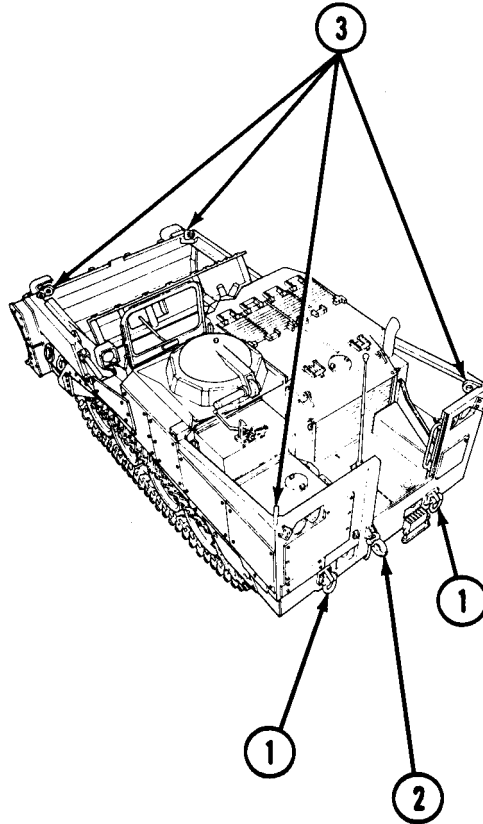

EMERGENCY PROCEDURES — CONTINUED

USING WINCH FOR SELF RECOVERY

CAUTION
 M9 can be damaged if correct recovery procedures are not followed. Refer to (FM20-22) for correct vehicle recovery procedures.

Note
 Before beginning self-recovery operations, secure hatch cover in 15° position.

- 1 Start the engine (p 2-37) and allow it to warm up for 3 to 5 minutes.
- 2 If bowl is loaded, unload bowl (p-2-67).
- 3 Place winch shift lever (1) in HIGH (down).

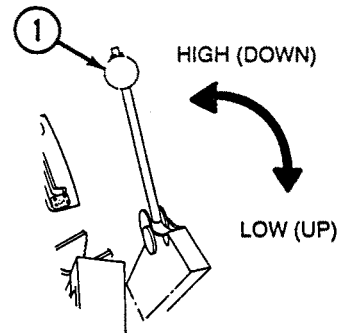

WARNING
 Always wear leather gloves when handling wire rope. Never allow wire rope to run through hands. Broken or frayed wires may cause injury to personnel.

- 4 Move winch stop (2) away from winch control lever (3) and move winch control lever (3) to out position. Pay out approximately 2 ft (61 cm).
- 5 Lift winch wire rope hook (4) from hull bracket (5).

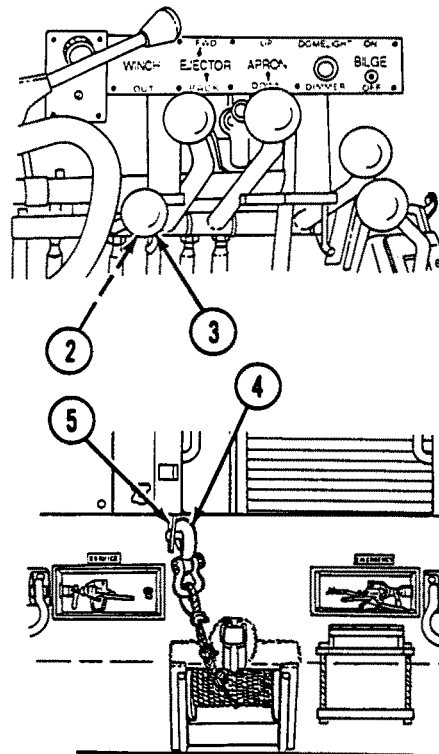

WARNING
 Do not operate winch with less than eight turns of wire rope on drum. Failure to comply may result in severe injury to personnel.

- 6 While operator is holding winch control lever (3) in out position, hand pull wire rope out and attach to a suitable anchor point, such as a large tree or heavy vehicle.

EMERGENCY PROCEDURES — CONTINUED

USING WINCH FOR SELF RECOVERY — CONTINUED

WARNING

Do not pull in load with winch shift lever in high speed. Failure to comply may result in severe injury to personnel.

- 7 Shift winch shift lever (1) into low speed.

- 8 Shift transmission shift lever (2) to R1.

WARNING

Always wear leather gloves when handling wire rope. Never allow wire rope to run through hands. Broken or frayed wires may cause severe injury to personnel.

- 9 Coordinate operation of accelerator (3) and winch control lever (4) to pay in wire rope and drive vehicle backwards until it is out of trouble.

CAUTION

The wire rope must be tightly wrapped to prevent damage to underwraps. If loosely wrapped, the wire rope top wrap may pull through the lower wrap and crush or kink it.

Note

At earliest opportunity, clean and lubricate wire rope in accordance with Appendix F.

- 10 Pay in and stow wire rope (p 2-75).

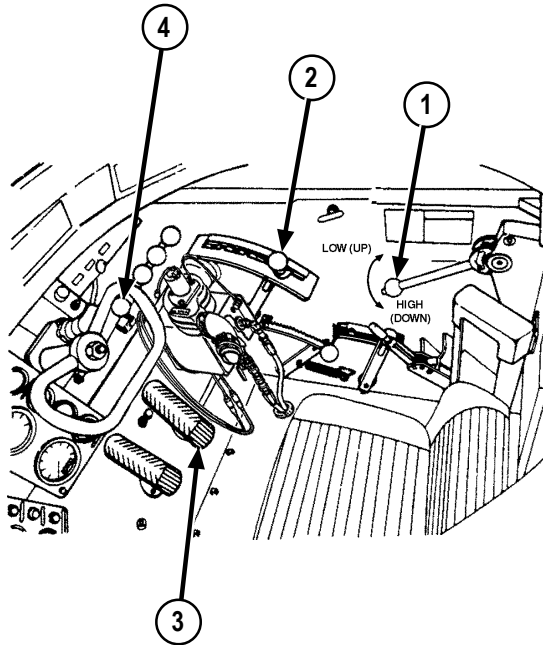

EMERGENCY PROCEDURES — CONTINUED

REMOVING MISFIRED SMOKE GRENADES

WARNING
 Smoke grenades can travel 410 ft (125 m) after firing. Fire smoke grenades only in authorized areas. Failure to comply may result in severe injury to personnel.

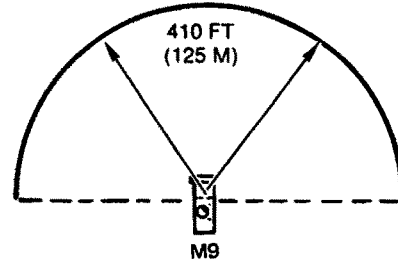

- 1 If a smoke grenade misfire is suspected, move vehicle to an area authorized for firing smoke grenade launchers.

WARNING
 Close driver's hatch cover before firing smoke grenades. Failure to comply may result in severe injury to personnel.

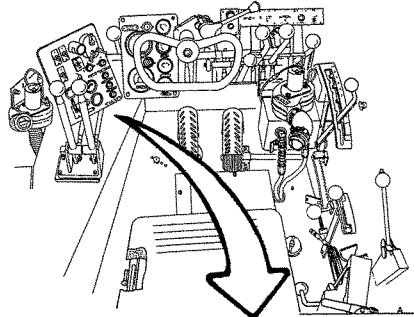

- 2 Refer to page 2-92 and fire smoke grenades. If misfire still exists, go to step 3.

WARNING

- Smoke grenade launchers use an electrical firing pin. Turn vehicle MASTER SWITCH OFF before unloading smoke grenades from tubes. Failure to comply may result in severe injury to personnel.
- If misfired smoke grenades fire during unloading, they can cause severe injuries. NEVER place any part of your body in front of smoke grenade launchers.

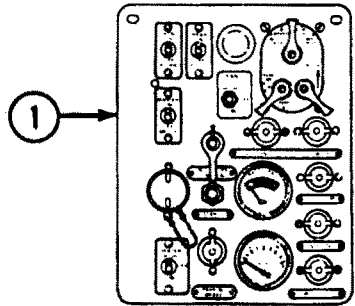

- 3 Turn vehicle MASTER SWITCH (1) to OFF.

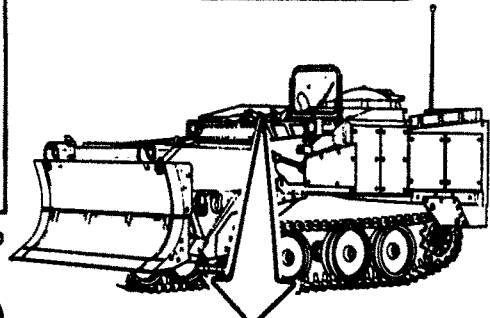

- 4 Remove misfired smoke grenades (2) from the side of tubes (3). Hold smoke grenade (2) from the side, and carefully pull and twist smoke grenade from tube (3).

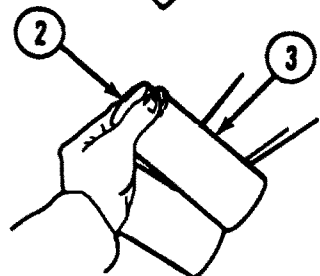

- 5 Move smoke grenades to a well-marked spot, at least 660 ft (201 m) from vehicles, buildings, personnel, or equipment.

EMERGENCY PROCEDURES — CONTINUED

REMOVING MISFIRED SMOKE GRENADES — CONTINUED

- 6 Notify ordnance disposal of exact location, type, and number of grenades left at safe location.
- 7 Notify unit maintenance that smoke grenade launchers on your vehicle have malfunctioned.

EMERGENCY ENGINE SHUTDOWN

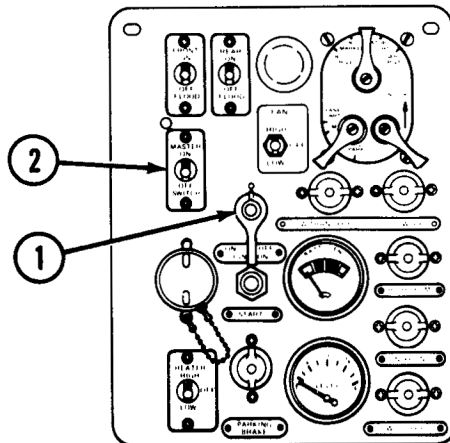

Turn IGNITION switch (1) to OFF and turn MASTER SWITCH (2) to OFF.

EMERGENCY PROCEDURES - CONTINUED

IN CASE OF FIRE

Note

It is necessary to stop the vehicle and the engine to prevent engine compartment air flow from removing any of the fire extinguisher agent.

- 1 Fixed fire extinguisher handle (1) is located in driver's compartment on the right side, just above and behind transmission shifter. Handle (2) is located on the right outside of the vehicle.
- 2 Upon noticing fire, turn MASTER SWITCH and IGNITION switch to OFF. Pull on fire extinguisher handle (1). Dismount with portable fire extinguisher. Pull on handle (2).

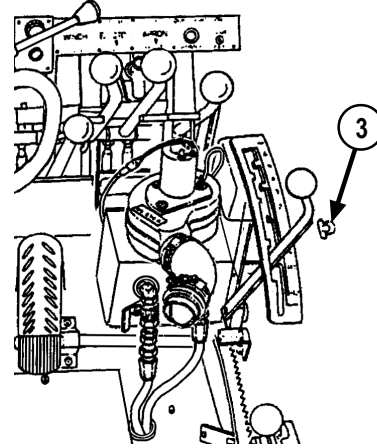

WARNING

Under no circumstances should any cover or grille leading to the engine compartment be opened when a fire exists. Failure to comply may result in severe injury to personnel or death.

- 3 Put out any remaining or recurring flames with portable fire extinguisher.

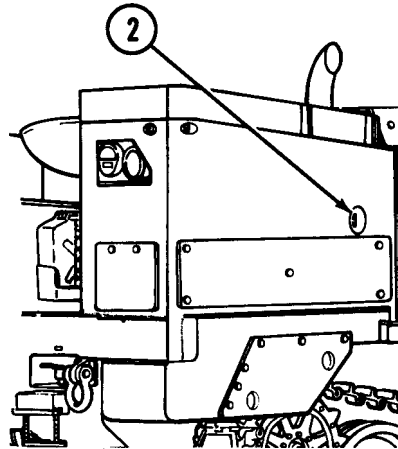

CHAPTER 3

MAINTENANCE INSTRUCTIONS

Section I.	Lubrication Instructions	3-1
Section II.	Troubleshooting	3-2
Section III.	Maintenance Procedures	3-13
Section IV.	Maintenance of Auxiliary Equipment	3-29

Section I. LUBRICATION INSTRUCTIONS

Appendix F provides and illustrates the cleaning and lubricating procedures as to locations, intervals, and proper materials for the M9 ACE. Any special lubricating instructions for specific mechanisms or parts are contained in the specific section. ■

Section II. TROUBLESHOOTING

SCOPE

The table lists the common malfunctions which you may find during the operation or maintenance of the M9 Armored Combat Earthmover or its components. You should perform the tests/inspections and corrective actions in the order listed.

This manual cannot list all malfunctions that may occur, nor all tests or inspections and corrective actions. If a malfunction is not listed or is not corrected by listed corrective actions, notify your supervisor.

MALFUNCTION**TEST OR INSPECTION****CORRECTIVE ACTION**

ENGINE

1 STARTER FAILS TO CRANK ENGINE WHEN START BUTTON IS DEPRESSED.

Step 1 Check to see IGNITION switch and MASTER SWITCH are ON and transmission shift lever is in (N) neutral position.

Turn on MASTER SWITCH and IGNITION switch to on position and move transmission shift lever to (N) neutral position.

WARNING

- Do not smoke, have open flames, or make sparks around batteries when checking or filling. The batteries can explode and injure you.
- Remove all jewelry, dog tags, bracelets, etc. If jewelry or disconnected battery ground cable contacts battery terminal, a direct short will result, causing instant heating of tools, damage to equipment, and severe injury to personnel.
- Electrolyte is extremely harmful. Always wear safety goggles and rubber gloves when performing battery maintenance. Injury will result if electrolyte contacts eyes or skin.

CAUTION

Do not hammer terminal clamps onto battery posts. This can cause severe damage to the batteries. Spread the ends of terminal adapters if they are too tight.

TROUBLESHOOTING — CONTINUED

MALFUNCTION	TEST OR INSPECTION	CORRECTIVE ACTION
-------------	--------------------	-------------------

ENGINE — CONTINUED

Step 2 Check battery terminal clamps for loose or corroded connections to battery. Check serviceability of batteries.

Clean and tighten terminal clamps (p 3-19). Apply grease (GAA) to terminal and clamps.

Step 3 Depress start button, and listen for solenoid engagement click.

If no click is heard, notify unit maintenance.

2 ENGINE CRANKS, BUT DOES NOT START.

WARNING

Fuel is a combustible material. Do not smoke or allow sparks or open flames into areas where fuel is present. Failure to comply may result in severe injury to personnel or death. If injured, seek medical attention immediately.

Step 1 Visually check fuel level in tank.

Service and fill empty fuel tank (p 3-20).

Step 2 Check that fuel shutoff valve (1) at fuel tank is in open position.

Turn fuel shutoff valve (1) to open position (handle aligned with hose).

Step 3 Check for air block in fuel/water separator (2).

With fuel shutoff valve (1) open, open vent valve (3) on top of fuel/water separator (2). When fuel/water separator (2) is full of fuel, close vent valve (3).

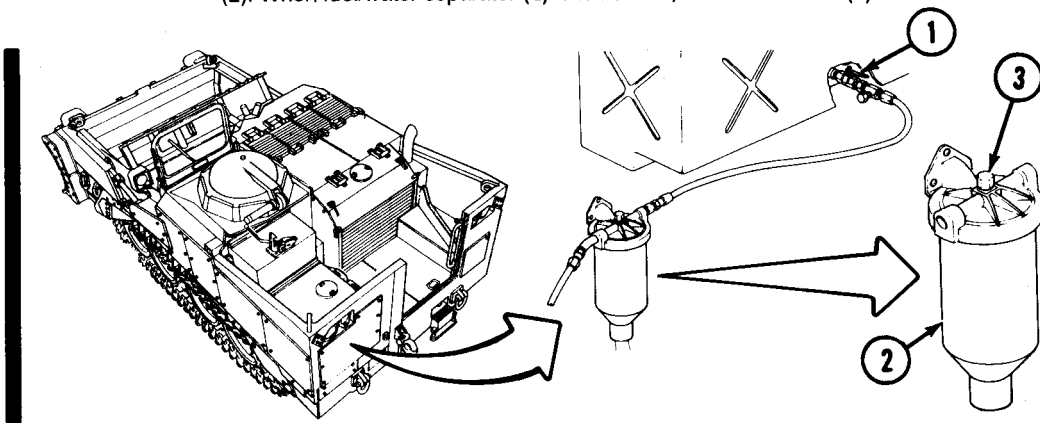

TROUBLESHOOTING — CONTINUED

MALFUNCTION

TEST OR INSPECTION

CORRECTIVE ACTION

ENGINE — CONTINUED

Step 4 Check for wrong grade of fuel (p 1-10).

Determine grade of fuel with fueling station. If necessary, have unit maintenance drain fuel tank and fill with correct grade of fuel.

Step 5 Check that fuel solenoid valve is operating by turning IGNITION switch ON-OFF-ON, and listen for solenoid engagement click.

If no click is heard, notify unit maintenance.

Step 6 Check air intake for restrictions and air cleaner for clogged element.

Remove restricting material and clean air filter element (p 3-23).

3 ENGINE RUNS ERRATIC, OR MISSES, AFTER NORMAL WARMUP.

WARNING

Fuel is a combustible material. Do not smoke or allow sparks or open flames into areas where fuel is present. Failure to comply may result in severe injury to personnel or death. If injured, seek medical attention immediately.

Step 1 Check for water in fuel/water separator (1). Open fuel shutoff valve (2), disconnect hose (3) from fuel/water separator (1), and drain accumulated water into a suitable container.

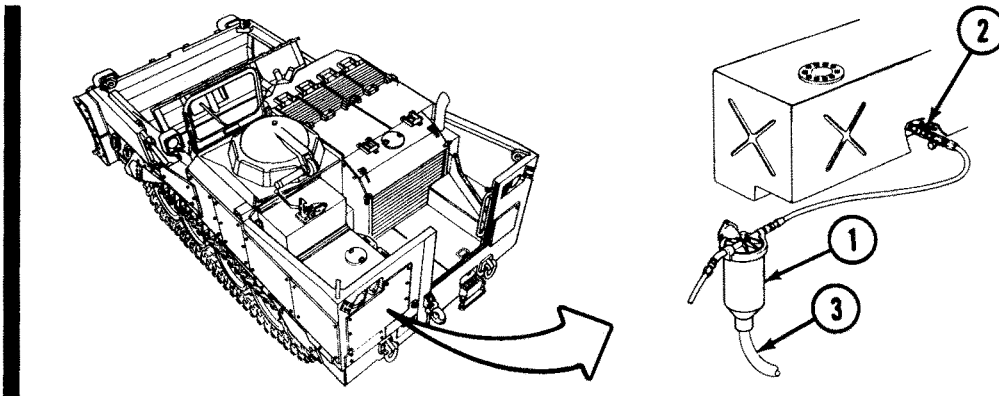

TROUBLESHOOTING — CONTINUED

MALFUNCTION	TEST OR INSPECTION	CORRECTIVE ACTION
--------------------	---------------------------	--------------------------

ENGINE — CONTINUED

Step 2 Check air intake for restrictions and air cleaner for clogged element.
 Remove restricting material and clean air filter element (p 3-20).

Step 3 Check muffler and exhaust system for restrictions or clogged muffler.

4 ENGINE SMOKES EXCESSIVELY AFTER NORMAL WARMUP.

Step 1 Check air intake for restrictions and air cleaner for clogged element.
 Remove restricting material and clean air filter element (p 3-23).

Step 2 Check for wrong grade of fuel (p 1-10).
 Determine grade of fuel with fueling station. If necessary, have unit maintenance drain fuel tank and fill with correct grade of fuel.

Step 3 Check engine WATER temperature indicator for low operating temperature after warmup period.
 If temperature is below 150°F (66°C) (green range), notify unit maintenance.

Step 4 Check oil and coolant for contamination or decreasing levels without external leakage.
 If so, notify unit maintenance.

5 ENGINE STOPS SUDDENLY DURING OPERATION.

Step 1 Check fuel supply.
 If fuel tank shutoff valve is closed, open valve. Fill empty fuel tank (p 3-20).

Step 2 Check air intake for restrictions and air cleaner for clogged element.
 Remove restricting material and clean air filter element (p 3-23).

Step 3 Check for water in fuel/water separator. Open fuel shutoff valve, disconnect hose, and drain accumulated water into a suitable container.

Step 4 Check battery generator indicator with IGNITION switch in ON position for amount of electrical current in the system.
 If no current exists, clean and tighten terminal clamps (p 3-19). Apply grease (GAA) to terminal and clamps. If fault is not corrected, notify unit maintenance.

TROUBLESHOOTING — CONTINUED

MALFUNCTION

TEST OR INSPECTION

CORRECTIVE ACTION

ENGINE — CONTINUED

6 ENGINE OVERHEATS IN NORMAL OPERATION.

Step 1 Check for low coolant level in radiator.

Add coolant as required (p 3-20). Check for coolant leaks and tighten loose connections.

Step 2 Check for debris blocking air passages of intake grilles, exhaust grilles, and radiator.

Clean debris and dirt from radiator.

Step 3 Check for broken or slipping fan belt.

Have unit maintenance adjust belt tension. If belt is frayed or broken, notify unit maintenance.

Step 4 Check for low engine oil level.

Add oil to proper level (**Appendix F**).

Step 5 Check for high engine oil level.

High oil level may indicate a coolant leak. If oil level is well above full mark, notify unit maintenance.

Step 6 Check for restricted exhaust system such as bent or crushed exhaust pipes.

If exhaust pipes are damaged, notify unit maintenance.

Step 7 Check engine exterior for caked mud or dirt.

Wash exterior of engine. If fault is not corrected, notify unit maintenance.

7 ENGINE DOES NOT IDLE SMOOTHLY.

Step 1 Check air intake for restrictions and air cleaner for clogged element.

Remove restricting material and clean air filter element (p 3-23).

TROUBLESHOOTING — CONTINUED

MALFUNCTION	TEST OR INSPECTION	CORRECTIVE ACTION
-------------	--------------------	-------------------

ENGINE — CONTINUED

WARNING

Fuel is a combustible material. Do not smoke or allow sparks or open flames into areas where fuel is present. Failure to comply may result in severe injury to personnel or death. If injured, seek medical attention immediately.

Step 2 Check fuel supply.

If fuel shutoff valve is partially closed, open valve. Fill empty fuel tank (p 3-20).

Step 3 Check for water in fuel/water separator (1). Open fuel shutoff valve (2), disconnect hose (3) from fuel/water separator (1), and drain accumulated water into a suitable container.

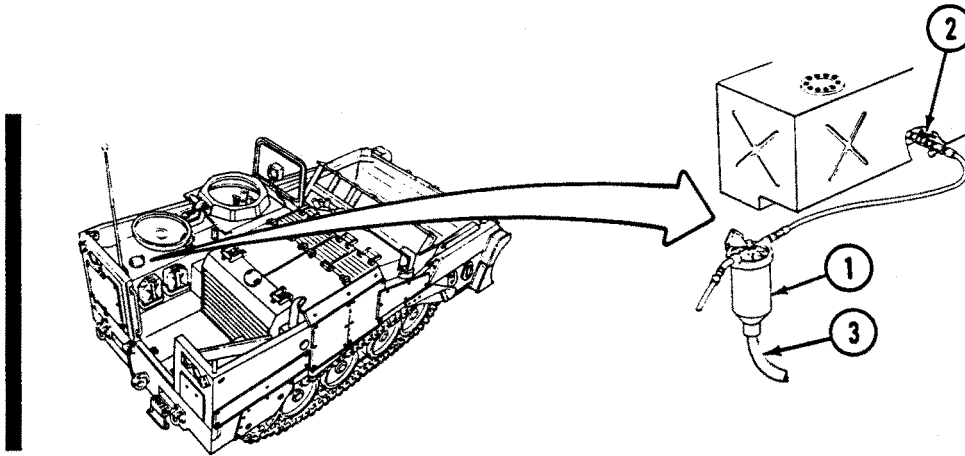

Step 4 Check WATER temperature indicator for low operating temperature after engine has warmed up for 3 to 5 minutes.

If reading is below 150°F (66°C) (green range), notify unit maintenance.

TROUBLESHOOTING — CONTINUED

MALFUNCTION

TEST OR INSPECTION

CORRECTIVE ACTION

ENGINE — CONTINUED

Step 5 Check battery generator indicator for quick movements, or "jumping," indicating a short circuit in the electrical system.

Check electrical connections or notify unit maintenance.

8 EXCESSIVE FUEL CONSUMPTION.

Step 1 Check air intake for restrictions and air cleaner for clogged element.

Remove restricting material and clean air filter element (p 3-23).

Step 2 Check for evidence of fuel leaks around tanks, fuel lines, and filters.

Report loose connections and damaged fuel system components to unit maintenance.

9 LOW ENGINE OIL PRESSURE INDICATION.

CAUTION

Engine should be stopped immediately after indication of low oil pressure. If low oil pressure reading persists after performing recommended checks, notify unit maintenance. Failure to comply may result in damage to equipment.

Step 1 Check for low engine oil level.

Add oil to proper level (Appendix F).

Step 2 Check for lubricating oil leaks.

Notify unit maintenance of any damaged or loose engine oil components, lines, and fittings.

Step 3 Check engine for overheating.

Refer to malfunction 6 (p 3-6).

TROUBLESHOOTING — CONTINUED

MALFUNCTION

TEST OR INSPECTION

CORRECTIVE ACTION

ENGINE — CONTINUED

10 EXCESSIVE OIL CONSUMPTION.

Step 1 Check for high engine oil level.

High oil level may indicate a coolant leak. If oil level is well above full mark, notify unit maintenance.

Step 2 Check for engine oil leaks.

Notify unit maintenance of any damaged or loose engine oil components, lines, and fittings.

Step 3 Check for diluted or too light grade engine oil.

Drain and refill crankcase with correct grade of oil (**Appendix F**).

CONTROLS

11 PARKING BRAKE CANNOT BE ENGAGED, OR DOES NOT HOLD VEHICLE.

Check adjustment of parking brake handle.

Rotate handle to tighten or loosen parking brake tension (**p 3-17**). If condition is not corrected, notify unit maintenance.

12 VEHICLE DOES NOT RESPOND, OR RESPONDS ERRATICALLY TO DRIVER'S CONTROLS.

Step 1 Check controls for binding or disconnected linkage. Inspect hydraulic valves, hoses, and tubes for oil leakage.

Tighten loose connections.

Report any damaged or defective components to unit maintenance.

Step 2 Refer to chapter 2 for correct operating procedures.

Operate controls as instructed for desired operation. If fault is not corrected, notify unit maintenance.

TROUBLESHOOTING — CONTINUED

MALFUNCTION

TEST OR INSPECTION

CORRECTIVE ACTION

CONTROLS — CONTINUED

13 HYDRAULIC FUNCTIONS ARE ERRATIC OR UNUSUALLY NOISY.

Step 1 Check oil level in hydraulic reservoir (Appendix F).

Add hydraulic oil to proper level (Appendix F). If trouble is not corrected, notify unit maintenance.

Step 2 Check hydraulic tubes and hoses for leaks.

Tighten loose connections. Report any damaged or defective components to unit maintenance.

14 BILGE PUMP DOES NOT EXPEL WATER FROM HULL.

Note

Engine must be running to provide hydraulic power to bilge pump.

Step 1 Check bilge pump screen for accumulation of debris.

Clean debris from area around bilge pump screen and clean bilge pump screen (p 3-22).

Step 2 Operate bilge pump (p 3-22) and check for air being expelled from outlet.

If no air is expelled, or if bilge pump does not operate, notify unit maintenance.

MALFUNCTION
TEST OR INSPECTION
CORRECTIVE ACTION

CONTROLS — CONTINUED

15 LIGHTS DIM, VENTILATION FAN IS SLOW, OR SMOKE GRENADE LAUNCHERS FIRE ERRATICALLY.

Step 1 Check batteries for loose connections (p 3-19) and electrolyte level (p 3-18).

Step 2 Check for loose or missing alternator belts.

Have unit maintenance adjust belt tension.

If any belts are frayed or broken, or problem persists, notify unit maintenance.

16 BRAKES DO NOT FUNCTION CORRECTLY.

Step 1 Check air lines for leakage.

Step 2 Check reservoir drain valve for sticking.

If any of these problems exist, notify unit maintenance.

TROUBLESHOOTING — CONTINUED

MALFUNCTION

TEST OR INSPECTION

CORRECTIVE ACTION

CONTROLS — CONTINUED

17 VEHICLE LOSES POWER ON ACCELERATION.

- Step 1 Check air intake for restrictions and air cleaner for clogged element.
Remove restricting material and clean air filter element (p 3-23).
- Step 2 Check to see that dozer is not attempting to cut too deep.
- Step 3 Check for restricted exhaust system.
If restricted or damaged, notify unit maintenance.
- Step 4 Check for partially closed fuel shutoff valve.
Open valve.
- Step 5 Listen for slipping transmission.
If so, notify unit maintenance.

Section III. MAINTENANCE PROCEDURES

PREPARATION FOR MAINTENANCE

Some of the operator tasks require vehicle preparation before starting work. They are required to ensure operator safety, prevent damage to the equipment, and to make the job easier to perform. The following procedures should be performed when required by the maintenance or inspection task:

- Relieving hydraulic pressure
- Relieving air pressure

RELIEVING HYDRAULIC PRESSURE

- 1 Shut off engine (p 2-45) with SPRUNG/UNSPRUNG control (1) in SPRUNG position.
- 2 Relieve pressure from main accumulator by slowly moving SPRUNG/UNSPRUNG control lever (1) toward UNSPRUNG position until a hissing can be heard. Hold in that intermediate position until hissing ceases.
- 3 Operate each of the four control levers (2) several times, through all positions, to relieve any residual pressure in hydraulic subsystems.
- 4 Loosen hydraulic tank dipstick (3) to allow air pressure to escape. Tighten dipstick (3).

RELIEVING AIR PRESSURE

- 1 Shut off engine (p 2-45).
- 2 Press air valve (4) at the rear of vehicle. Hold air valve (4) in until no air is heard escaping from the air valve.

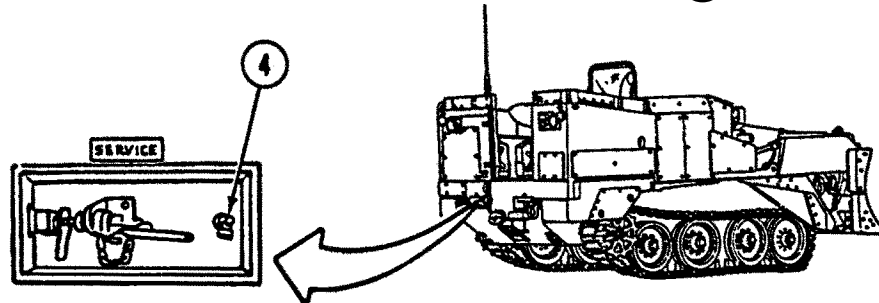
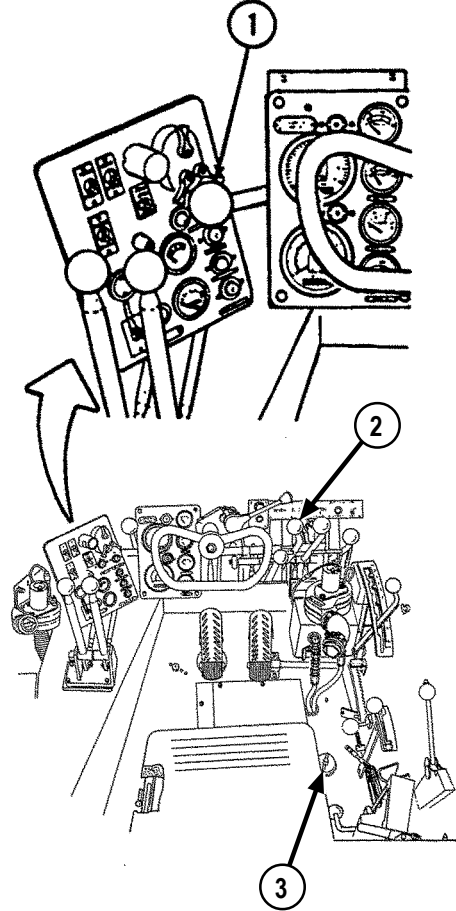

ARMOR PLATES — EXTERIOR

The following steps are to be used for the removal or installation of the fifteen exterior armor plates. Some of these must be removed for air transportation.

Note

- If armor plate 4R must be removed, and vehicle is equipped with front forward smoke grenade storage box, contact unit level maintenance to remove front forward smoke grenade storage box.
- For air transport on C-130 and C-141 aircraft, remove armor plates 4R and 5R.

REMOVAL

Note

- Circles around screws indicate which screws are removed first from each armor plate.
- If armor plate 4R must be removed, and vehicle is equipped with front forward smoke grenade storage box, contact unit level maintenance to remove front forward smoke grenade storage box.

- 1 In removing each armor plate, first remove the two screws, washers, and lockwashers that are encircled in the illustrations below.

Note

Armor plate 1L or 1R must be removed before 2L or 2R.

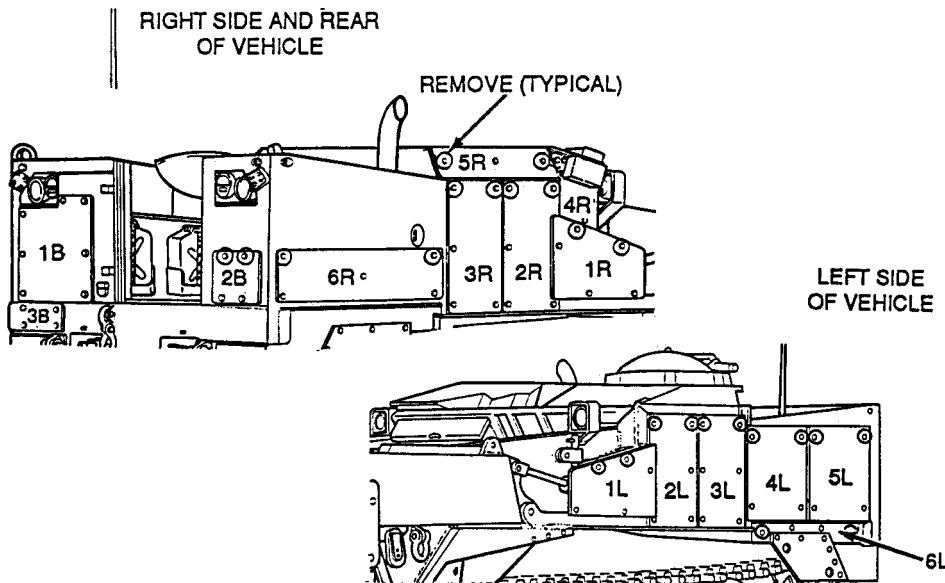

ARMOR PLATES — EXTERIOR — CONTINUED

REMOVAL — CONTINUED

- 2 Install two armor alignment pins in place of two removed screws.
- 3 Remove all other screws, washers, and lockwashers attaching armor plate, allowing it to hang from pins.

WARNING

Make sure feet are firmly planted on a level surface, or use a helper, when removing armor plates. Some armor plates weigh 50 lb (23 kg). Handle armor plates with extreme care to avoid injury.

- 4 Using both hands, slide armor plate from pins and place in bowl.
- 5 After removing armor plate 4R (1), remove filler plate (2) from pins.

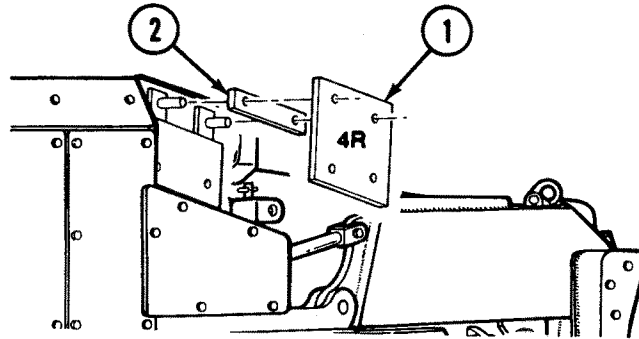

- 6 Remove two pins and stow all screws, washers, and lockwashers in holes they were removed from.

INSTALLATION

- 1 Remove screws, washers, and lockwashers from attaching holes on hull.
- 2 Install two alignment pins in upper holes for armor plate to be installed.

Note

- Armor plate 2R or 2L must be installed before 1R or 1L.
 - If armor plate 4R must be installed, and vehicle is equipped with front forward smoke grenade storage box, contact unit level maintenance to install front forward smoke grenade storage box.
- 3 Before installing armor plate 4R (1), install filler plate (2) on pins.
 - 4 Remove appropriate armor plate from bowl and install on two pins.
 - 5 Install screws, washers, and lockwashers in armor plate and tighten. Notify unit maintenance to torque screws as soon as possible.
 - 6 Remove two pins and install two screws, washers, and lockwashers and tighten. Notify unit maintenance to torque screws as soon as possible.

ENGINE EXHAUST GRILLES

REMOVAL

- 1 Release two latches (1) and open lid (2).
- 2 Lift out four exhaust grilles (3).

INSTALLATION

Note

Make sure exhaust grilles are properly aligned in brackets to eliminate interference when removing battery box cover.

- 1 Install four exhaust grilles (3) in brackets (4).
- 2 Close lid (2) and close two latches (1).

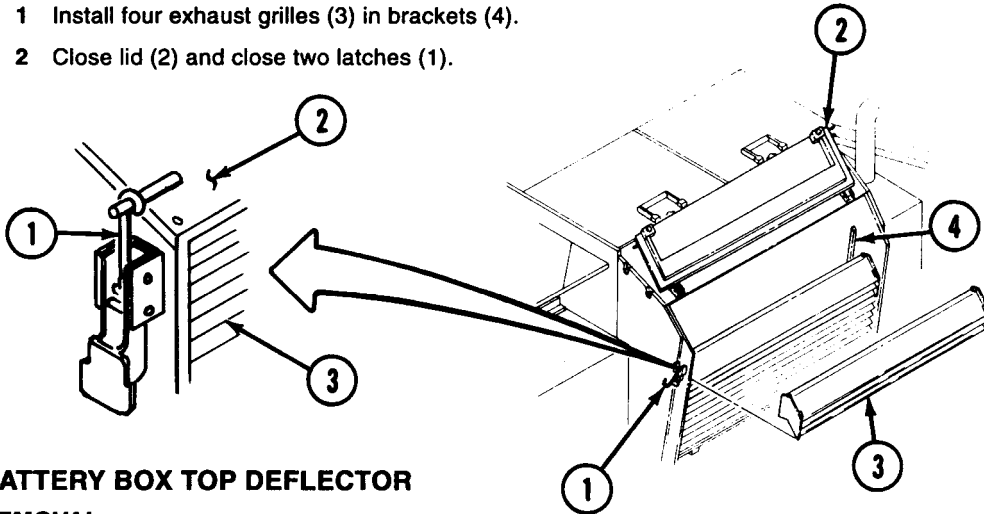

BATTERY BOX TOP DEFLECTOR

REMOVAL

Remove battery box top deflector (1) from cylinder fastener (2) and cylinder latch (3).

INSTALLATION

Note

To obtain proper fit of battery box top deflector, it may be necessary to adjust two brackets by loosening and retightening screws on bracket.

Install battery box top deflector (1) with cylinder fastener (2) and cylinder latch (3).

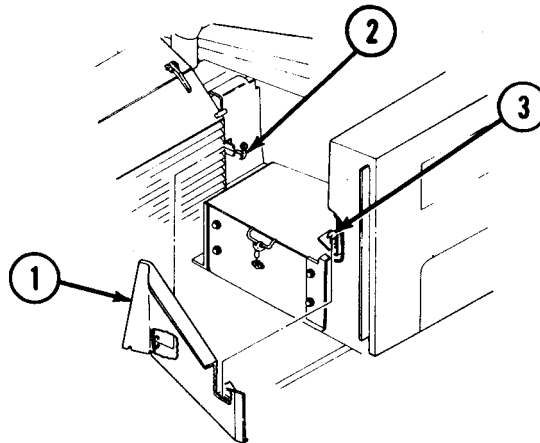

PARKING BRAKE LEVER ADJUSTMENT

WARNING

Block track or roadwheels when parking brake is released. Vehicle can roll, causing damage to equipment, severe injury to personnel, or death.

- 1 Start engine (p 3-37) to pressurize airbrake system. Wait until low air light and buzzer go off before proceeding.
- 2 Apply the service (foot) brake and move parking brake lever (1) forward to full release position.
- 3 Turn adjusting knob (2) on parking brake lever (1) clockwise as tightly as possible by hand.

Note

Parking brake must be set with engine running and foot brake applied. Setting the parking brake does not engage the brake system, it only locks the service brakes in the applied position.

- 4 Apply the service brake pedal and try to pull the parking brake lever (1) up and over center. If lever (1) cannot be set in position, loosen adjusting knob (2) counterclockwise until the lever (1) can be set. If repeated attempts fail, notify unit maintenance.
- 5 Set parking brake and test the brake to see if it will hold the vehicle stationary. Shift transmission into 5th gear and apply power (about 100 rpm over idle speed) to see if parking brake will hold. If brake does not hold vehicle, notify unit maintenance.

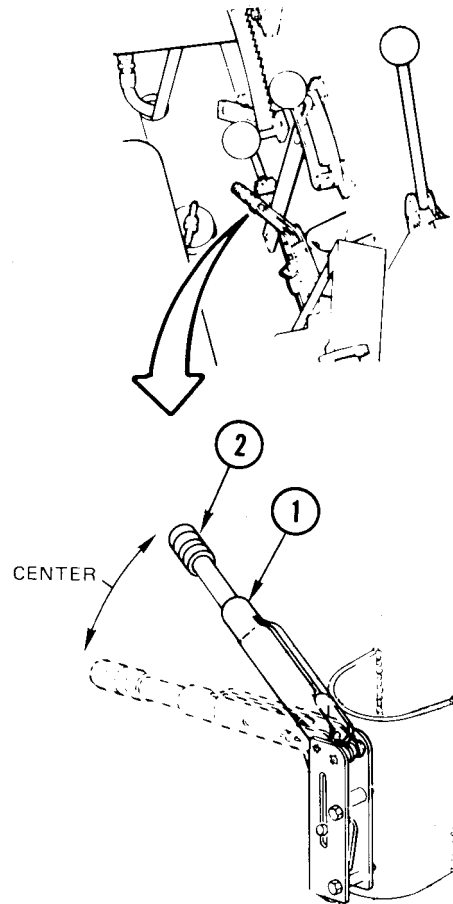

BATTERIES

WARNING

- Do not smoke, have open flames, or make sparks around batteries. The batteries can explode and injure you.
- Remove all jewelry, such as rings, dog tags, bracelets, etc. If jewelry or disconnected battery ground cable contacts battery terminal, a direct short will result, causing instant heating of tools, severe injury to personnel, and damage to equipment.
- Electrolyte is extremely harmful. Always wear safety goggles and rubber gloves when performing battery maintenance. Injury will result if electrolyte contacts eyes or skin.
- Do not use battery box top deflector as a step. Failure to comply may result in damage to equipment or injury to personnel.

ELECTROLYTE LEVEL

Note

During hot weather (ambient air temperature 80°F (27°C) or above), check electrolyte level daily to be sure it is level with split rings. Evaporation increases with rise in ambient temperature.

- 1 Unhook two latches and pull battery box top deflector clear of battery box.
 - 1.1 Remove battery box cover.
- 2 Clean off battery caps before removing. Do not allow dirt to get into battery cells.
- 3 Clean vent holes in caps to allow gas to escape from cells.
- 4 Electrolyte level must not drop below the top of battery plates. Add distilled water to correct level indicator mark. Do not overfill. Add only distilled water from a nonmetallic container. Clean rainwater may be used in an emergency. In hot weather, check more often.
- 5 Run vehicle to charge batteries, which will mix added water with the electrolyte. This is very important in cold weather to prevent battery from freezing and cracking.
- 6 When check is complete, install battery box cover.. Install battery box top deflector ensuring end of deflector is seated firmly in bracket on radiator armor shroud, and secure with two latches.

BATTERIES — CONTINUED

WARNING

- Do not smoke, have open flames, or make sparks around batteries. The batteries can explode and injure you.
- Remove all jewelry, such as rings, dog tags, bracelets, etc. If jewelry or disconnected battery ground cable contacts battery terminal, a direct short will result, causing instant heating of tools, damage to equipment, and severe injury to personnel.
- Electrolyte is extremely harmful. Always wear safety goggles and rubber gloves when performing battery maintenance. Injury will result if electrolyte contacts eyes or skin.
- Do not use battery box top deflector as a step. Failure to comply may result in damage to equipment or injury to personnel.

CAUTION

If cables overheat, there may be corrosion or a break within the wiring, causing electrical resistance. Notify unit maintenance.

LOOSE CONNECTIONS

- 1 Terminal clamps must be all the way down on battery posts and tightly secured.
- 2 Battery holddowns must be snug, but not so tight as to damage battery case.
- 3 If bolts will not tighten, notify unit maintenance.
- 4 Check cables for loose or broken connections.
- 5 Notify unit maintenance for repair or replacement of battery cables and terminal clamps or if terminals are corroded.
- 6 Install battery box cover.

FUEL TANK — FILLING

WARNING

Fuel is a combustible material. Do not smoke or allow sparks or open flames into areas where fuel is present. Failure to comply may result in severe injury to personnel or death. If injured, seek medical attention immediately.

- 1 Make sure MASTER SWITCH is OFF.
- 2 Remove two thumbscrews (1) and cover (2) from fuel tank cover (3). Remove filler cap (4) from fuel tank (5).
- 3 Fill tank, leaving 4 in. (10 cm) air space for expansion.
- 4 Install filler cap (4) on fuel tank (5). Install cover (2) and two thumbscrews (1) on fuel tank cover (3). Tighten two thumbscrews (1) by hand only.

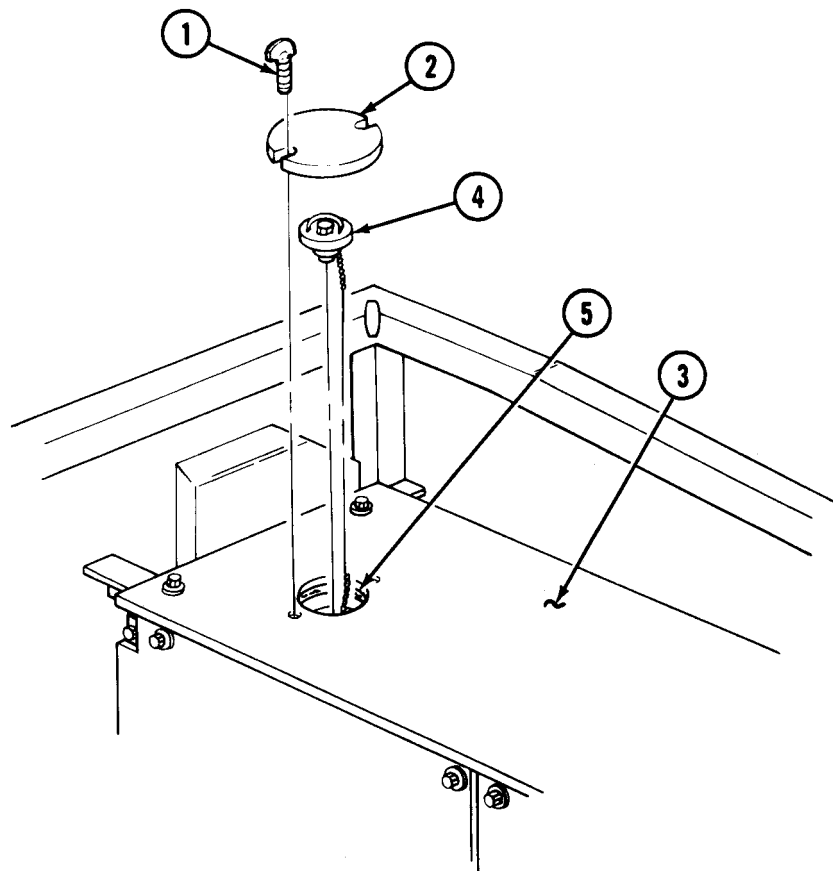

ENGINE INTAKE GRILLES AND ACCESS COVERS

The following steps are to be used for the opening, removal, and installation of the intake grilles and access covers.

OPENING

- 1 Release two latches (1) securing two access covers (2).
- 2 Lift up two access covers (2) or four grilles (3) as necessary to gain access to engine components.

REMOVAL

- 1 Remove twelve screws (4), washers (5), two hinges (6), and four hinges (7) from two access covers (2) and four grilles (3).
- 2 Lift and remove two access covers (2) and four grilles (3).

INSTALLATION

- 1 Position four grilles (3) and two access covers (2) on vehicle.
- 2 Install two hinges (6) and four hinges (7) on two access covers (2) and four grilles (3) with twelve washers (5) and screws (4).
- 3 Close two latches (1).

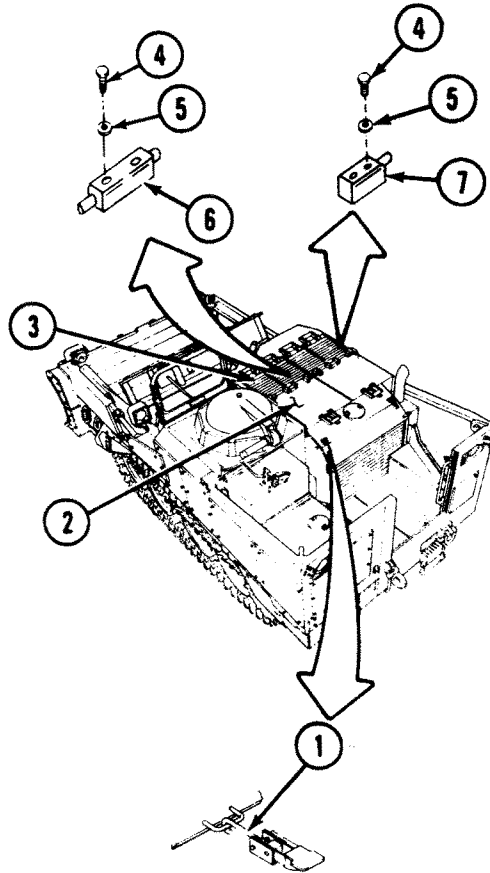

BILGE PUMP SCREEN — CLEANING

Note

Although the Bilge Pump is considered Not Mission Essential and will no longer be supported with spare and repair parts, this manual contains operational procedures For Your Information Only. Notify Unit maintenance if the bilge pump no longer operates.

- 1 Lift and remove left and right floor plates (1) and (2).
- 2 Remove two self-locking screws (3) and left floor plate support (4) from rear of vehicle.
- 3 Reach through opening and clean debris from bilge pump inlet screen (5).
- 4 Start engine (p 2-37) and remove bilge pump lever to ON (p 2-2). Using hand, check for air flow from pump outlet (6). If no air is expelled, or bilge pump does not operate, notify unit maintenance.
- 5 Install left floor plate support (4) with two self-locking screws (3).
- 6 Install left and center floor plates (1) and (2).

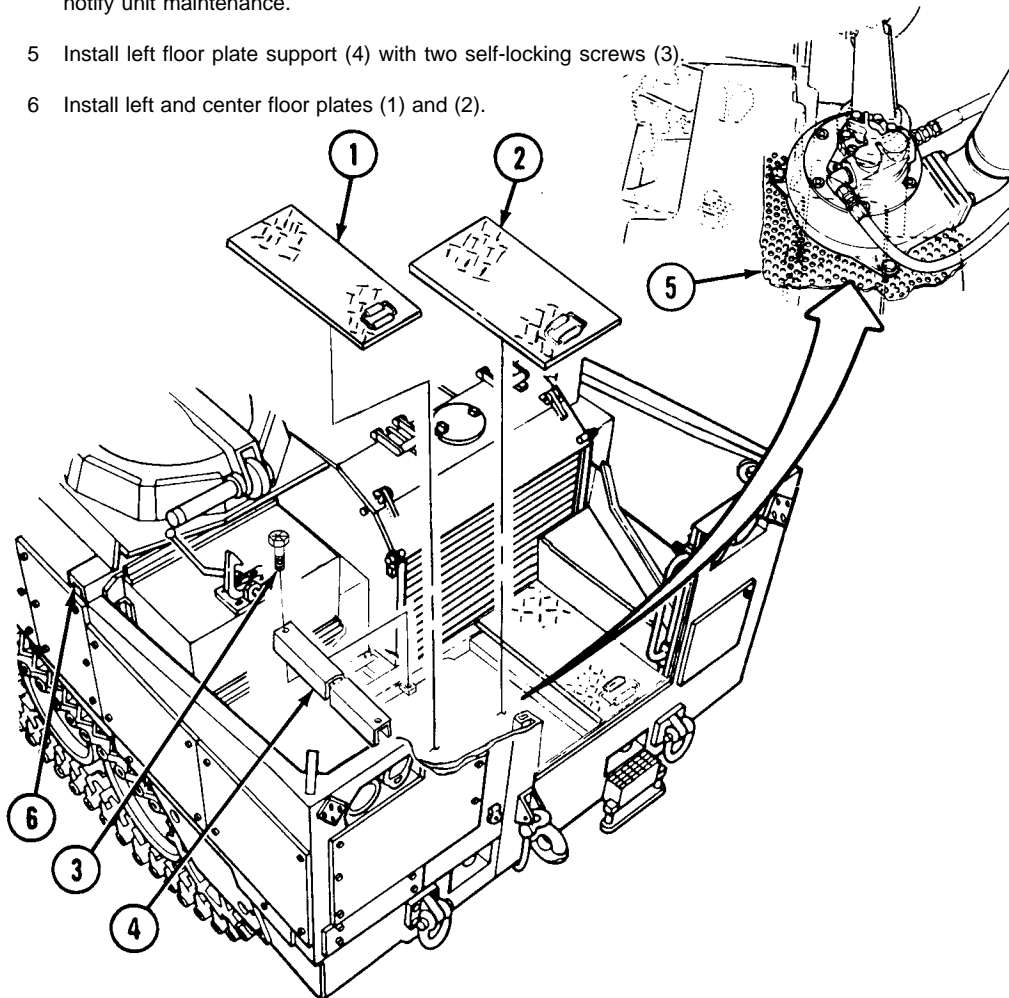

VENT FAN FILTER — SERVICE

WARNING
 Do not operate ejector when personnel are in bowl. Do not work in bowl unless ejector lock is engaged. Failure to comply may result in severe injury to personnel.

- 1 Move ejector forward (p 2-3).
- 2 From inside bowl, remove vent fan filter bracket (1) from driver's compartment wall.
- 3 Inspect hook tape (2) and loop tape (3). If damaged, notify unit maintenance.
- 4 Remove filter element (4) from vent fan filter bracket (1).
- 5 Tap end of filter element (4) gently against flat surface to jar loose particles and dust from element.

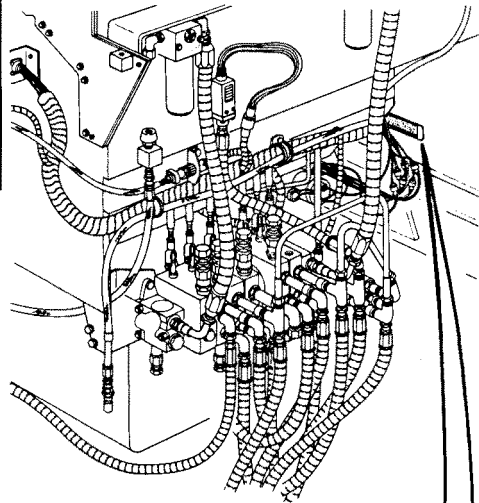

WARNING
 Compressed air can injure you and others. Do not aim compressed air hoses at anyone. Do not use more pressure than 30 psi (207 kPa). Always wear goggles. Failure to comply may result in injury to personnel.

- 6 Clean filter element (4) with mild soap and water solution. If available dry filter element (4) with compressed air.
- 7 Install filter element (4) in vent fan filter bracket (1).
- 8 Install vent fan filter bracket (1) on hook tape (2) on driver's compartment wall.
- 9 Retract ejector (p 2-3).

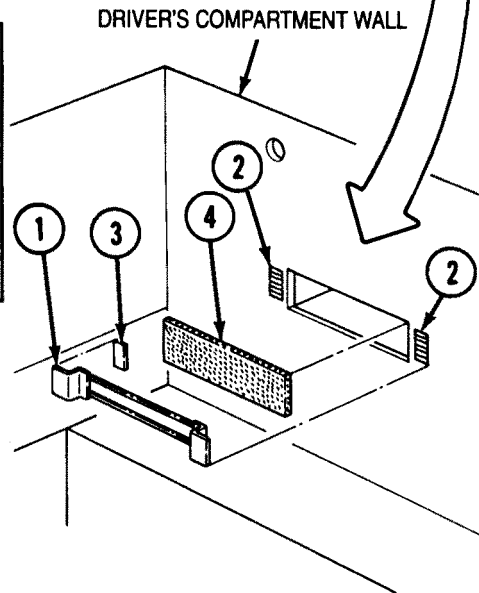

ENGINE AIR CLEANER — SERVICE

WARNING

Do not operate ejector when personnel are in bowl. Do not work in bowl unless ejector lock is engaged. Failure to comply may result in severe injury to personnel.

Note

Engine air cleaner must be serviced when service indicator is in red.

- 1 Move ejector forward (p 2-3).
- 2 Release three latches (1) and remove end cover (2) and gasket (3) from air cleaner (4).

WARNING

If NBC exposure is suspected, all air filter media should be handled by personnel wearing protective equipment.

- 3 Remove retainer (5), washer (6), and slide out element (7).

WARNING

Compressed air can injure you and others. Do not aim compressed air hoses at anyone. Do not use more pressure than 30 psi (207 kPa). Always wear goggles.

- 4 Tap end of element gently against flat surface to jar loose particles and dust from folds of element. If available, clean element with compressed air directed from inside element.
- 5 Hold light inside element and inspect for ruptures, holes, or tears. Check for damaged gaskets. Replace defective element.
- 6 Use cloth to wipe dust from inner wall of cleaner housing and end cover.

Note

When replacing a defective element, ensure that retainer, washer, gasket, and clip are installed with new element.

- 7 Install element (7), washer (6), and retainer (5) in air cleaner (4).

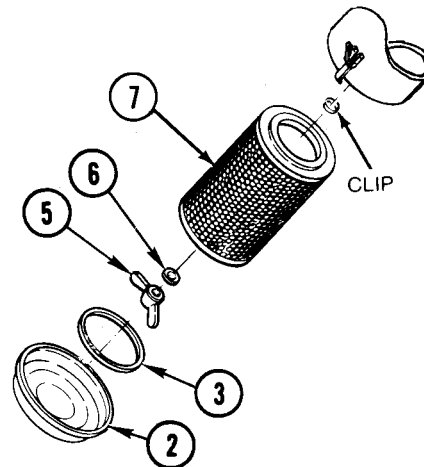
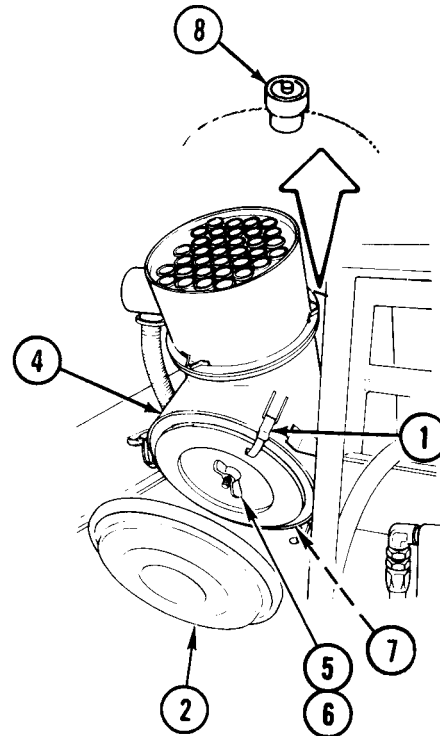

- 8 Install gasket (3) and end cover (2) on air cleaner (4) and close three latches (1).
- 9 Reset service indicator (8) by pressing down on top of indicator (8).

ADDING COOLANT

WARNING

Use extreme care in removing radiator cap from overheated cooling system to prevent severe burns from steam. Failure to comply may result in severe injury to personnel.

- 1 Lower engine speed to idle, on an overheated engine, until temperature drops to below 190°F (88°C). If the temperature continues to rise, shut off engine and allow it to cool before adding coolant.
- 2 Slowly remove radiator fill cap (1) from radiator.
- 3 With engine running, add coolant to bring level to bottom of tube in filler opening. Install and tighten cap (1).
- 4 Run engine for at least 5 minutes to eliminate any air pockets. Recheck coolant level, and add coolant if necessary.

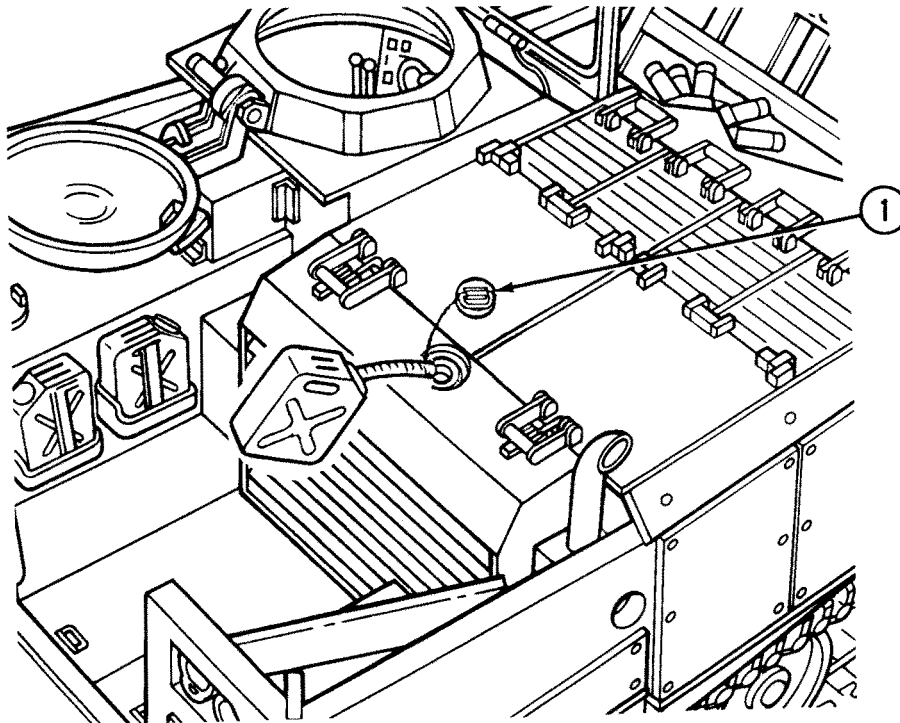

PORTABLE FIRE EXTINGUISHER

- 1 Check condition and operation of portable fire extinguisher latches (1).
- 2 Make sure extinguisher nozzle (2) is secure and serviceable. Check lead seals (3) to make sure they have not been broken.

Note

Notify unit maintenance of due date for quarterly inspection.

- 3 Check inspection tag (4) to be sure the extinguisher has been weighed and inspected within the past 90 days.
- 4 If extinguisher has not been weighed and inspected, or has been discharged, notify unit maintenance.

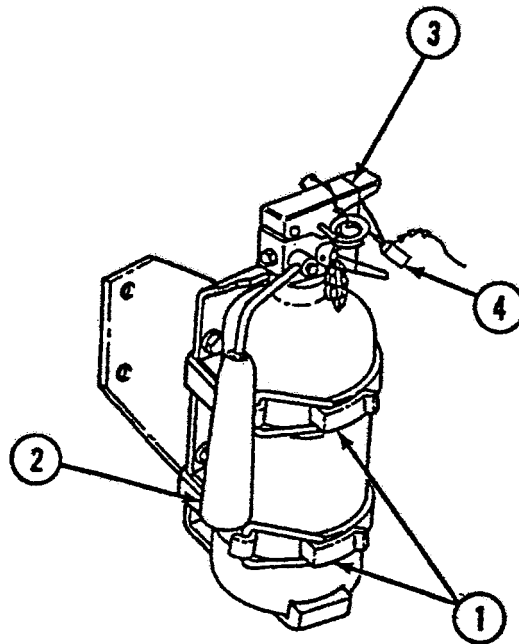

CO₂

TRACK ASSEMBLY MAINTENANCE

TRACK TENSION CHECK / ADJUSTMENT (OLD PRODUCTION)

Note

Ensure that bowl is empty before checking track tension.

- 1 Start engine (p 2-37).
- 2 Let engine run until suspension system is charged.
- 3 Place vehicle in SPRUNG mode, R1, CB mode, and drive vehicle in reverse at maximum speed for approximately 50 ft. (15 m) onto a hard, level surface. Shift to N, and allow vehicle to coast to a stop without using brakes or turning steering wheel. Do not set parking brake.
- 4 Adjust the hand throttle so engine idles at between 750-850 rpm to maintain hydraulic pressure. Allow engine to idle for 5 minutes so that the vehicle will settle into a constant position.

WARNING

Block track or roadwheels when parking brake is released. Vehicle can roll, causing damage to equipment, severe injury to personnel, or death.

Note

Record measurement from middle of top of No. 4 roadwheel to track.

- 5 Dismount vehicle and inspect track. The track should just touch the top of No. 3 roadwheel, and should be 1-1/4 to 2 in. (3.2 to 5.1 cm) above the top of No. 4 roadwheel.

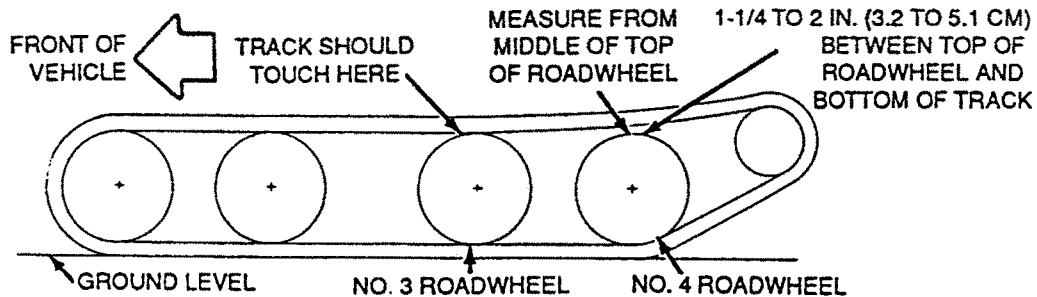

- 6 If track is less than 1-1/4 in. (3.2 cm) from top of No. 4 roadwheel, adjust tension as necessary.

Note

Ensure that dozer blade is unfolded (p 2-59).

- 7 Remove rear floor plates for access to track adjusting cylinders.

Note

Place rag or can under loosened fill valve to catch grease as it comes out of valve. A small amount of oil may also exit with grease.

Note

Ensure that bowl is empty before adjusting track tension.

- 8 To tighten track tension, loosen front fill valve (1) until second set of threads are visible and attach grease gun to rear fill valve (2).

TRACK TENSION CHECK / ADJUSTMENT (OLD PRODUCTION) (CONTINUED)

- 9 Pump grease into rear fill valve (2) until bottom of track touches top of No. 3 roadwheel and track is 1-1/4 to 2 in. (3.2 to 5.1 cm) from top of No. 4 roadwheel.
- 10 Tighten front fill valve (1) and remove grease gun from rear fill valve (2).
- 11 To decrease track tension, loosen rear fill valve (2) until second set of threads are visible and attach grease gun to front fill valve (1).
- 12 Pump grease into front fill valve (1) until bottom of track touches top of No. 3 roadwheel and track is 1-1/4 to 2 in. (3.2 to 5.1 cm) from top of No. 4 roadwheel.
- 13 Tighten rear fill valve (2) and remove grease gun from front fill valve (1). Notify unit maintenance to tighten front or rear fill valves to 20 to 30 lb-ft (27 to 41 N·m).
- 14 If track is more than 2 in. (5.1 cm) from top of No. 4 roadwheel, track tension **MAY** be too tight. Place vehicle in UNSPRUNG and lower front of vehicle until both ends of dozer blade touch the ground.
- 15 If the track is correctly adjusted, both ends of dozer blade will touch the ground. If track tension is too tight, it will not be possible to lower both ends of dozer blade to the ground.
- 16 If both ends of dozer blade do not touch the ground, adjust tension as necessary. If track tension cannot be adjusted, notify unit maintenance.
- 17 Check tension of other track in same manner.
- 18 Once track has been adjusted, repeat steps 3 through 5 to assure track has been properly adjusted.
- 19 Once the tracks have been adjusted properly, replace rear floor plates, proceed with mission.

Note

If unable to correctly adjust track tension, notify unit maintenance.

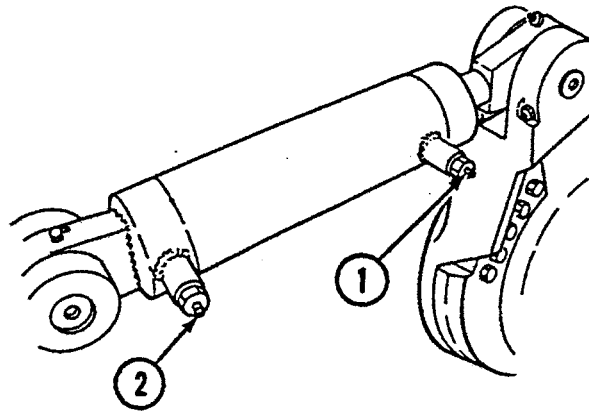

TRACK TENSION ADJUSTMENT (NEW PRODUCTION)

Note

Ensure that bowl is empty before adjusting track tension. Optimum track adjustment is when the track is in the tightest possible condition which still allows the vehicle to be lowered to the digging position.

It is normal to have short delays during lowering and raising while the semi-automatic track adjusting components function.

- 1 Start engine (p 2-37).
- 2 Place vehicle in **SPRUNG** mode and allow suspension system to stabilize.
- 3 Move left track adjust switch (1) momentarily (1 to 2 seconds) to **LOOSEN** position. Vehicle will move slightly as track adjust cylinder retracts.
- 4 Move right track adjust switch (2) momentarily (1 to 2 seconds) to **LOOSEN** position. Vehicle will move slightly as track adjust cylinder retracts.
- 5 Move both left (1) and right (2) track adjust switches to **TIGHTEN** position, 4 to 5 seconds. This will remove slack in track above roadwheels.
- 6 Move vehicle slightly forward to remove any slack in left and right tracks from behind the sprocket.
- 7 Place suspension in **UNSPRUNG** mode.

Note

Suspension control levers must remain in the **LOWER** position throughout Step 8. If levers are returned to the neutral position before completion of step, Step 8 must be repeated.

- 8 Push left (3) and right (4) suspension control levers forward to **LOWER** position and hold for 10 to 12 seconds. (After 2 to 4 seconds, observe front of vehicle begin to lower then stop momentarily. After approximately 8 seconds the front of vehicle will lower further, but **MAY** not completely drop to the ground.) If front of vehicle does not contact the ground, continue holding suspension control levers (3) and (4) in the lower position and move vehicle slightly forward, then **LIGHTLY TAP** left (1) or right (2) track adjuster switches to **LOOSEN** position until the corresponding side (left or right) lowers to the ground, (alternate between left and right switch to keep vehicle as level as possible during this step).
- 9 Return suspension control levers (3) and (4) to neutral position.

TRACK TENSION ADJUSTMENT (NEW PRODUCTION) (CONTINUED)

10 Pull both left (3) and right (4) suspension control levers rearward to RAISE position and level the vehicle. (Vehicle hull will stop momentarily while track adjusting cylinders function.)

11 Place suspension in SPRUNG mode. Proceed with mission.

Note

If unable to correctly adjust track tension, notify unit maintenance.

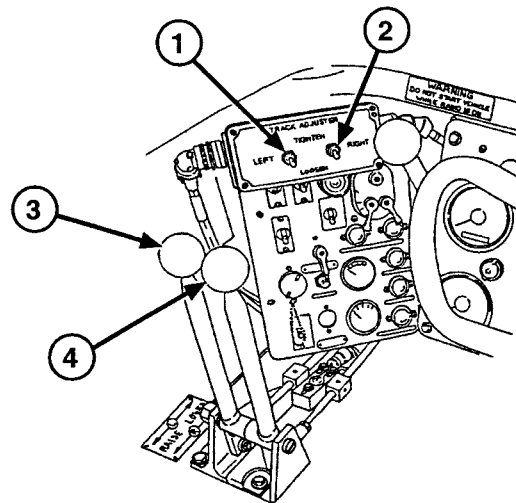

TRACK PAD

REMOVAL

- 1 Move vehicle forward, or backward, to position track pad (1) where easy access is allowed to both top and bottom of track pad (1).
- 2 Remove locknut (2) and washer (3) securing track pad (1) to track link (4).
- 3 Remove track pad (1).

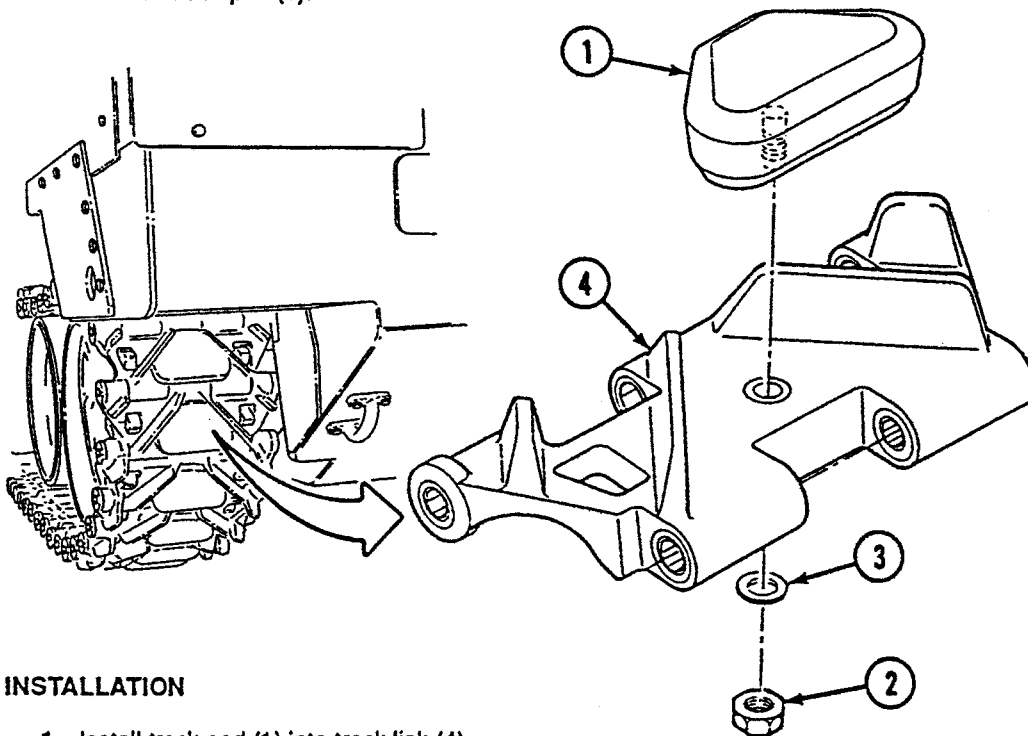

INSTALLATION

- 1 Install track pad (1) into track link (4).

Note

Coat threads of locknut and screw of pad with lubricating oil (OE/HDO-10) before installation.

- 2 Install locknut (2) and washer (3) on track pad (1) and tighten.
- 3 Notify unit maintenance to torque locknut as soon as possible.

Section IV. MAINTENANCE OF AUXILIARY EQUIPMENT

NBC MASK — DECONTAMINATING, CLEANING, AND CONDITIONING

DECONTAMINATING

Use the M258 individual Decontaminating and Reimpregnating Kit to decontaminate your mask. For detailed instructions, refer to FM 3-6.

CLEANING AND CONDITIONING

Refer to TM 3-4240-280-10 for more detailed instructions on cleaning and conditioning of mask.

- 1 Position canister (1) higher than mask (2).

CAUTION

Be careful not to get canister and microphone wet when washing.

- 2 Using cheesecloth dipped in warm, soapy water and wrung out almost dry, carefully wipe mask (2) both inside and out. A soft brush may also be used.
- 3 Wipe mask (2) with a clean cloth and warm, clear water with cloth wrung out almost dry.
- 4 Allow mask (2) to air dry or wipe dry with a lint-free cloth.
- 5 Check that nose cup valve disks (3) were not dislodged during cleaning.

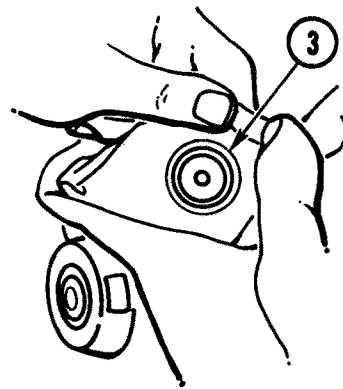
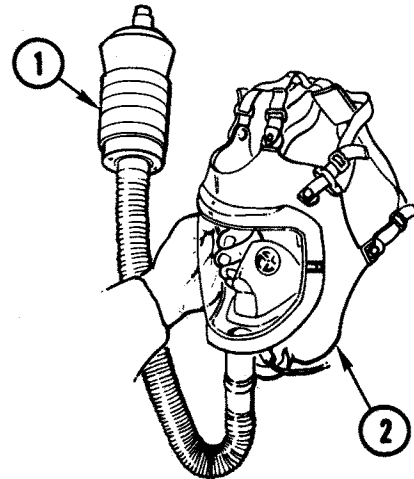

**NBC MASK — DECONTAMINATING, CLEANING, AND CONDITIONING —
CONTINUED**

CLEANING AND CONDITIONING — CONTINUED

- 6 Using optical lens cleaning compound or polishing compound, plastic, type 1, clean and polish lens (1).
- 7 Brush and wipe off surface dirt or mildew from hose (2), canister (3), and sling (4).
- 8 Brush any dirt or grit from carrier (5). If soiled, carrier (5) may be cleaned with a brush and cool, clear water and allow to air dry.

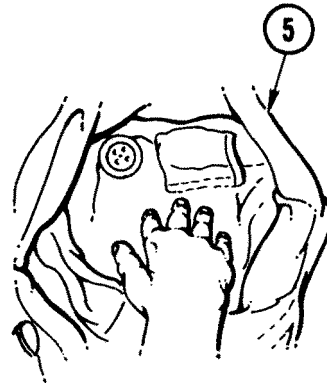
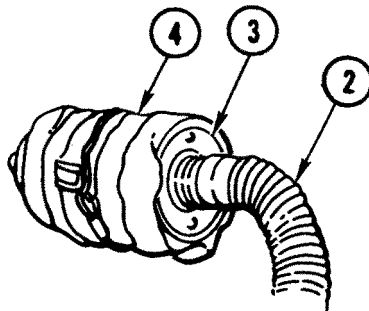
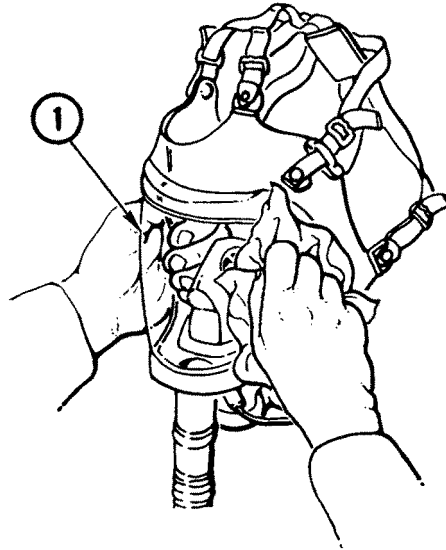

SMOKE GRENADE LAUNCHER — CLEANING AND INSPECTING

WARNING
 The smoke grenade launchers use an electrical firing pin. Do not work on smoke grenade dischargers or smoke grenade launcher tubes unless MASTER SWITCH and ARM OFF switch of arming firing unit is set to OFF. Failure to comply may result in injury to personnel.

- 1 Remove eight rubber caps (1) on eight smoke grenade launcher tubes (2) from two smoke grenade dischargers (3).
- 2 Use a piece of wire or other small probe to clean the drain holes (4) at the bottom of each smoke grenade launcher tube (2). Loosen and push out any dirt or debris from drain holes (4).
- 3 Use RBC (MIL-C-372) or CLP (MIL-L-63460) paint brush or 20 mm to 25 mm bore brush to clean inside of smoke grenade launcher tubes (2).
- 4 Dry inside of smoke grenade launcher tubes (2) with clean wiping rags.
- 5 Check smoke grenade launcher tubes (2) for damage.
- 6 Check that electrical firing pin (5) in each smoke grenade launcher tube (2) is not corroded.
- 7 Check that smoke grenade launcher tube (2) is secure on smoke grenade discharger (3).
- 8 Install eight rubber caps (1) on eight smoke grenade launcher tubes (2).

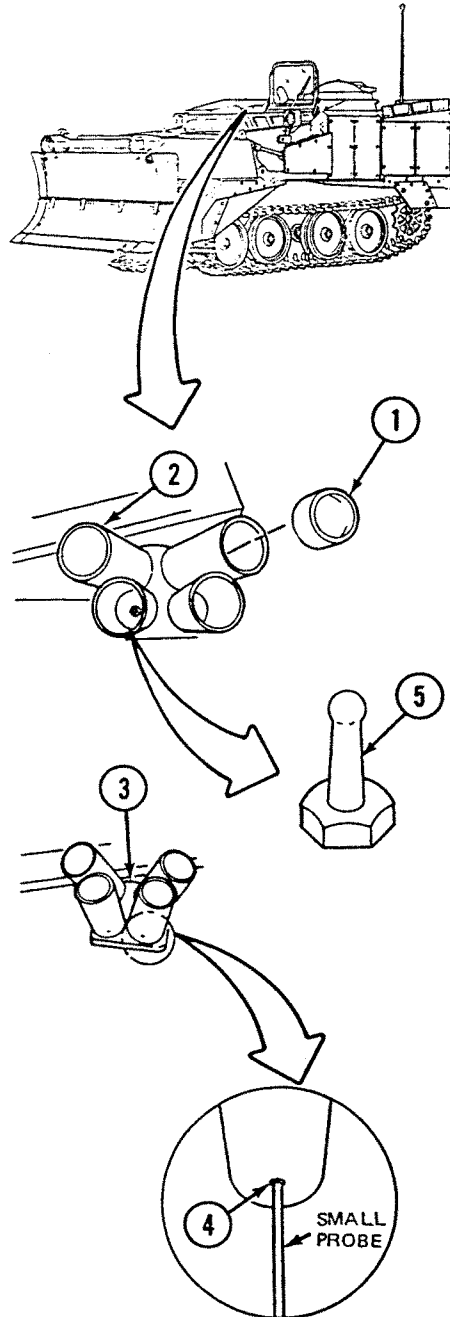

APPENDIX A REFERENCES

A-1. PUBLICATION INDEXES

DA Pam 25-30 Consolidated Index of Army Publications and Blank Forms

A-2. FORMS

Refer to DA Pam 738-750, The Army Maintenance Management System (TAMMS), for instructions on the use of maintenance forms pertaining to the vehicle.

A-3. PUBLICATION REFERENCES

General

- AR 25-30 The Army Integrated Publishing and Printing Program
- CTA 50-970 Expendable/Durable Items (Except Medical, Class V, Repair Parts, and Heraldic Items)
- DA Pam 738-750 The Army Maintenance Management System (TAMMS)
- FM 5-20 Camouflage
- FM 9-207 Operation and Maintenance of Army Materiel in Extreme Cold Weather 0 to -65°F (TO 36-1-40)
- FM 20-22 Vehicle Recovery Operations
- FM 21-11 First Aid for Soldiers
- FM 21-60 Visual Signals
- FM 31-70 Basic Cold Weather Manual
- FM 31-71 Northern Operations
- FM 90-3 (HTF) Desert Operations (How to Fight)
- FM 90-6 (HTF) Mountain Operations (How to Fight)
- MIL-M-63042C (TM) Manuals, Technical:
 - Procedures for Destruction of Equipment to Prevent Enemy Use
- TC 25-7 Training Management Skills, Unit Development
- TM 5-331A Utilization of Engineer Construction Equipment: Volume A; Earthmoving, Compaction, Grading, and Ditching Equipment
- TM 9-238 Deepwater Fording of Ordnance Materiel
- TM 43-0139 Painting Instructions for Field Use

Vehicle

- FM 21-306 Manual for Tracked Combat Vehicle Driver
- TB 750-651 Use of Antifreeze Solutions and Cleaning Compounds in Engine Cooling Systems
- TM 5-2350-262-10-HR Hand Receipt Manual Covering End Item/Components of End Item (COEI), Basic Issue Items (BI), and Additional Authorization List (AAL) for Armored Combat Earthmover (ACE), M9

A-3. PUBLICATION REFERENCES — CONTINUED

Vehicle — Continued

- TM 9-6140-200-14 Operator's Organizational, Direct Support and General Support Maintenance Manual for Lead-Acid Storage Batteries: 4HN, 24 V, MS75047-1; 2HN, 12 V; 6 TN, 12 V
- TM 5-2350-262-14 Technical Manual: Transportability Guidance Armored Combat Earthmover, M9

Night Vision Equipment

- TM 11-5855-238-10 Operator's Manual for Night Vision Goggles, AN/PVS-5 and AN/PVS-5A
- TM 11-5855-238-10-HR Hand Receipt Manual Covering End Item/Components of End Item (COEI), Basic Issue Items (BI), and Additional Authorization List (AAL) for Night Vision Goggles AN/PVS-5 and AN/PVS-5A

Chemical, Biological, and Nuclear

- FM 3-4 NBC Protection
- FM 3-5 NBC Decontamination
- FM 3-6 Field Behavior of NBC Agents (Including Smoke and Incendiaries)
- TF 3-4899 CBR Decontamination, Unit Level, MCB Proficiency
- TM 3-4230-214-12&P Operator's and Organizational Maintenance Manual Including Repair Parts and Special Tools Lists: Decontaminating Apparatus, Portable DS2, 1 1/2 Quart, ABC M11
- TM 3-4240-280-10 Operator's Manual: Mask, Chemical-Biological, Aircraft, ABC-M24 and Accessories; Mask, Chemical-Biological, Tank, M25 and Accessories; Mask, Chemical-Biological, Tank, M25A1 and Accessories
- TM 3-4240-282-L List of Applicable Publications (LOAP) 12 and 20 CFM Gas- Particulate Filter Units
- TM 3-6910-227-10 Operator's Manual: Training Set, Chemical Agent Identification: Simulants, M72A2
- TM 43-0001-26-1 Army Equipment Data Sheets, Chemical Defense Equipment

Communications

- SB 11-131-2 Vehicular Radio Sets and Authorized Installations, Volume II
- TM 11-5820-890-10-3 Operator's Manual for SINCGARS Radio AN/VRC-87
- TM 11-5820-890-10-HR Hand Receipt Manual Covering End Item/Components of End Item (COEI), Basic Issue Items (BI), and Additional Authorization List (AAL) for SINCGARS Radio AN/VRC-87
- TM 11-5820-498-12 Operator's and Organizational Maintenance Manual; Radio Sets AN/VRC-53, AN/VRC-64, AN/VRC-125, and AN/VRC-160.
- TM 11-5820-498-12-HR Hand Receipt Manual Covering End Items (BI), and Additional Authorization List (AAL) for Radio Sets, AN/VRC-53, AN/VRC-64, AN/VRC-125, and An/VRC-160.

APPENDIX B

COMPONENTS OF END ITEM AND BASIC ISSUE ITEMS LISTS

Section I. INTRODUCTION

B-1. SCOPE

This appendix lists components of end item and basic issue items for the M9 to help in locating items required for safe and efficient operation.

B-2. GENERAL

The Components of End Item and Basic Issue Items Lists are divided into the following sections:

- a. Section II. Components of End Item. This listing is for informational purposes only and is not authority to requisition replacements. These items are part of the end item, but are removed and separately packaged for transportation or shipment. As part of the end item, these items must be with the end item whenever it is issued or transferred between property accounts. Illustrations are furnished to assist in identifying the items.
- b. Section III. Basic Issue Items. These are the minimum essential items required to place the M9 in operation, to operate it, and to perform emergency repairs. Although shipped separately packaged, BII must be with the M9 during operation and whenever it is transferred between property accounts. The illustrations will assist with hard-to-identify items. This manual is the authority to request/requisition replacement BII, based on TOE/MTOE authorization of the end item.

B-3. EXPLANATION OF COLUMNS

The following provides an explanation of columns found in the tabular listings:

- a. Column (1) — Illustration Number (Illus Number). This column indicates the number of the illustration in which the item is shown.
- b. Column (2) — National Stock Number. Indicates the National stock number assigned to the item and will be used for requisitioning purposes.

B-3. EXPLANATION OF COLUMNS — CONTINUED

- c. Column (3) — Description. Indicates the Federal item name and, if required, a minimum description to identify and locate the item. The last line for each item indicates the Commercial and Government Entity Code (CAGEC), in parentheses, followed by the part number.

- d. Column (4) — Unit of Measure (U/M). Indicates the measure used in performing the actual operational/maintenance function. This measure is expressed by a two-character alphabetical abbreviation (e.g., ea, in., pr).

- e. Column (5) — Quantity Required (Qty Rqr). Indicates the quantity of the item authorized to be used with/on the equipment.

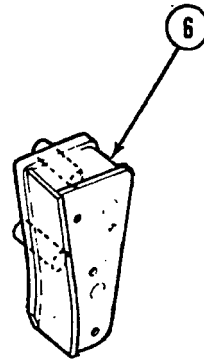
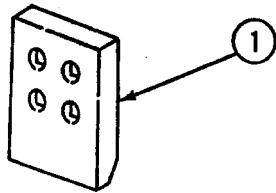

Section II. COMPONENTS OF END ITEM

(1) Illus Number	(2) National Stock Number	(3) Description CAGEC and Part Number	Usable On Code	(4) U/M	(5) Qty Rqr
1	3805-01-453-7669	Bit, End (19207) 12466264		EA	2
2		Deleted			
3		Deleted			
4		Deleted			
5		Deleted			
6	2590-01-185-0169	Extension, Apron, LH Assembly (97403) 13214E2482		EA	1

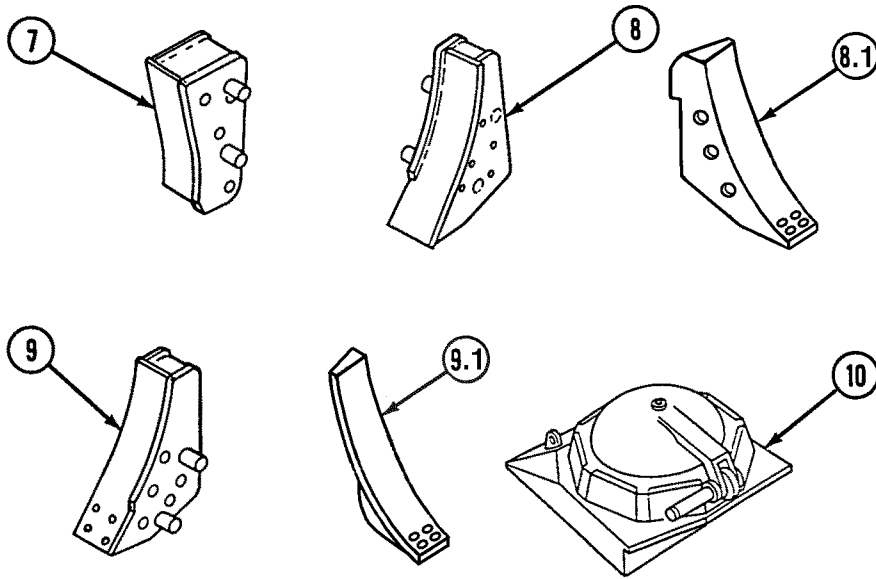

Section II. COMPONENTS OF END ITEM – CONTINUED

(1) Illus Number	(2) National Stock Number	(3) Description CAGEC and Part Number	(4) Usable On Code U/M	(5) Qty Rqr
7	2590-01-182-8768	Extension, Apron, RH Assembly (97403) 13214E2481	EA	1
8	2590-01-182-8767	Extension, Dozer, LH Assembly (97403) 13214E2483	EA	1
8.1		Extension, Dozer, LH Assembly (31969) 115M2090 (NEW PRODUCTION)	EA	1
9	2590-01-182-8769	Extension, Dozer, RH Assembly (97403) 13214E2484	EA	1
9.1		Extension, Dozer, RH Assembly (31969) 115M2092 (NEW PRODUCTION)	EA	1
10		Hatch Assembly, Driver's (19207) 12362200	EA	1

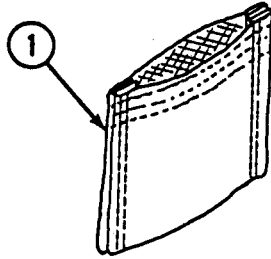

Section III. BASIC ISSUE ITEMS

(1) Illus Number	(2) National Stock Number	(3) Description CAGEC and Part Number	Usable On Code	(4) U/M	(5) Qty Rqr
1	8105-01-185-0514	Bag, Textile (19207) 12334739 (For armor alignment pins stowage)		EA	1
2		Deleted			
3		Deleted			
4		Deleted			

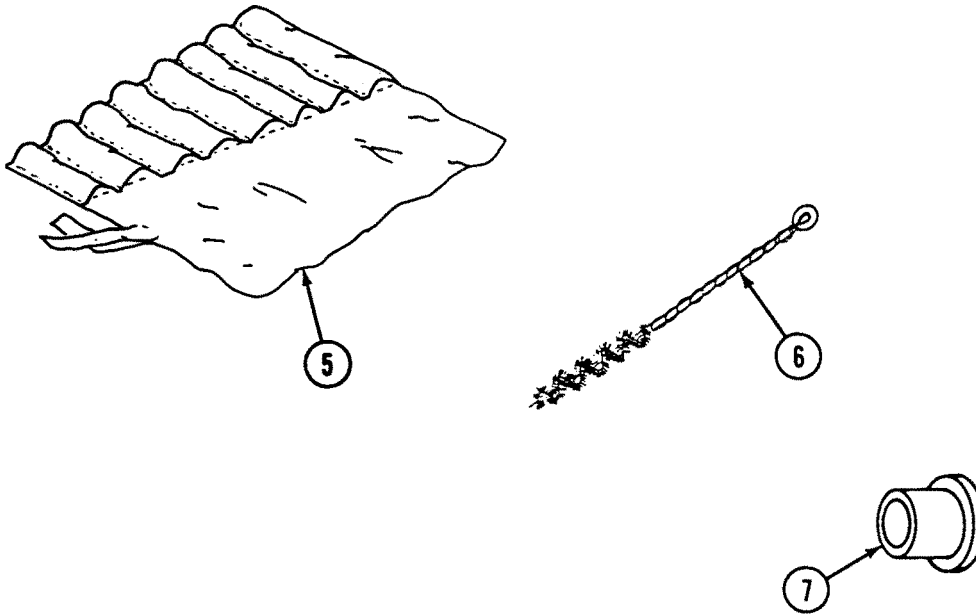

Section III. BASIC ISSUE ITEMS – CONTINUED

(1) Illus Number	(2) National Stock Number	(3) Description CAGEC and Part Number	(4) Usable On Code U/M	(5) Qty Rqr
5	5140-00-473-6256	Bag, Tool, Satchel (34623) 11655979	EA	1
6	1005-00-722-5087	Brush, Cleaning, Small Arms (19205) 7225087 (For cleaning smoke grenade launcher)	EA	1
7	5340-01-113-0879	Cap-Plug, Protective, Dust and Moisture Seal (81349) M5501/7-F11 (For armor alignment pin threads protection)	EA	6

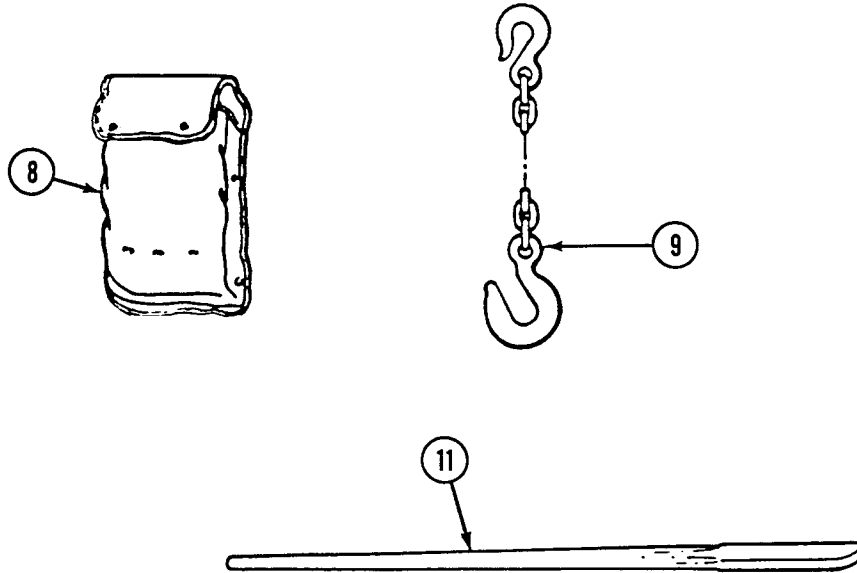

Section III. BASIC ISSUE ITEMS – CONTINUED

(1) Illus Number	(2) National Stock Number	(3) Description CAGEC and Part Number	Usable On Code	(4) U/M	(5) Qty Rqr
8	7520-00-559-9618	Case, Maintenance and Operational Manuals (81349) MIL-C-11743		EA	1
9	4010-01-185-0406	Chain Assembly, Single Leg (97403) 13211E9331 (For folding and unfolding the dozer/ripper blade and palletized cargo handling)		EA	1
10		Deleted			
11	5120-00-224-1390	Crowbar, 62 in. maximum Type II, Class 1, Size 4 (80064) 1833244		EA	1

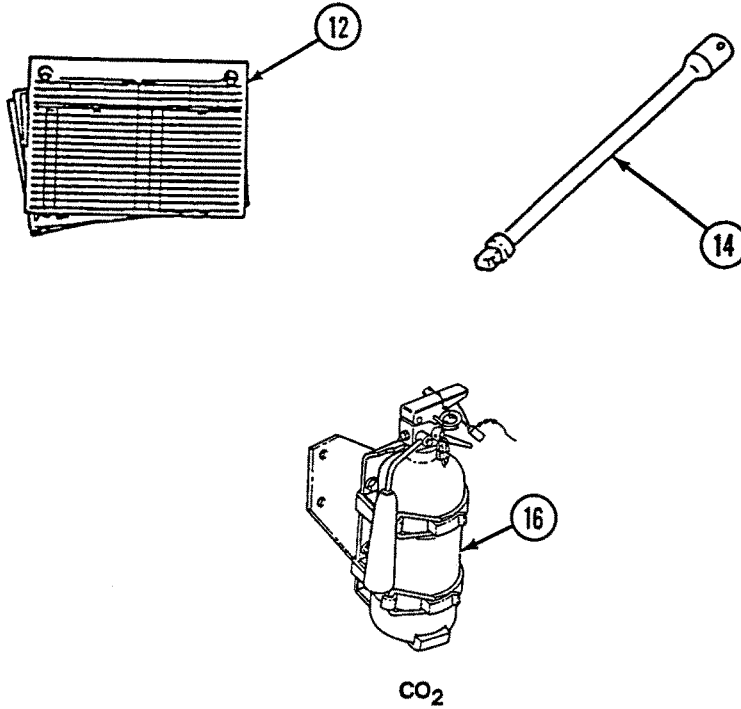

Section III. BASIC ISSUE ITEMS - CONTINUED

(1) Illus Number	(2) National Stock Number	(3) Description CAGEC and Part Number	(4) Usable On Code U/M	(5) Qty Rqr
12		DA Forms 2408, 2408-9, 2408-20, 2409	EA	A/R
13		Deleted		
14	5120-00-227-8074	Extension, Socket Wrench, 10 in. (19207) 11655788-1 (For final drive caps removal)	EA	1
15		Deleted		
16	4210-01-388-7854	Extinguisher, Fire, CO ₂ 2-1/2 lb, (19207) 12295774	EA	1

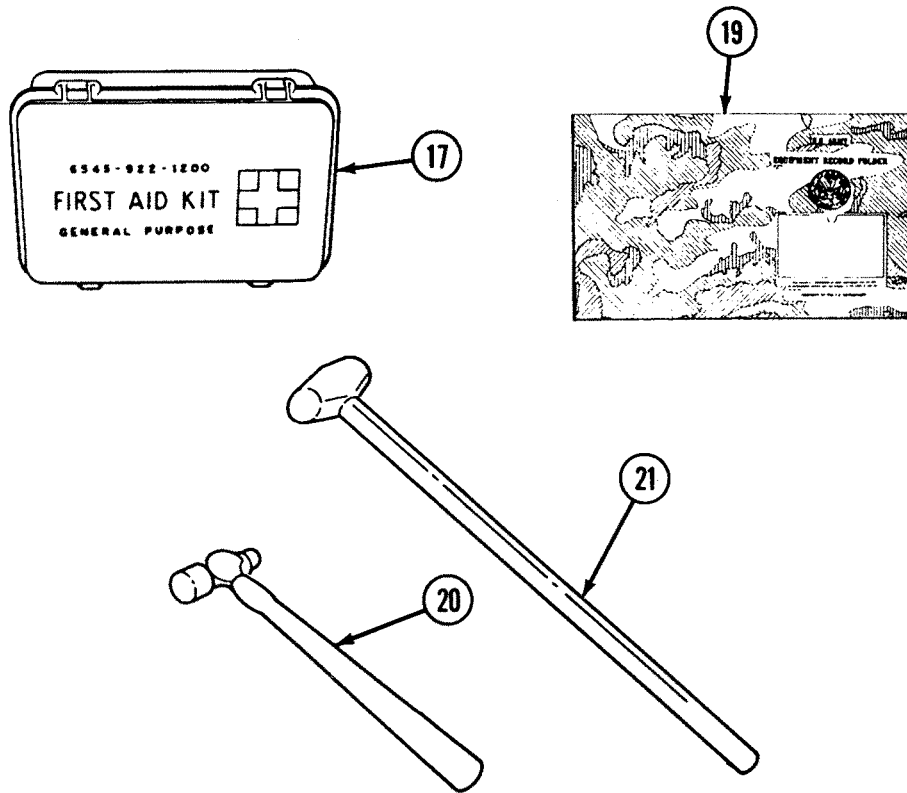

Section III. BASIC ISSUE ITEMS – CONTINUED

(1) Illus Number	(2) National Stock Number	(3) Description CAGEC and Part Number	(4) Usable On Code U/M	(5) Qty Rqr
17	6545-00-922-1200	First Aid Kit, General Purpose (19207) 11677011	EA	1
18		Deleted		
19	7510-01-065-0166	Folder (81349) MIL-F-43986	EA	1
20	5120-00-061-8543	Hammer, Hand, 16 oz Round or Octagonal Cross Section (19207) 11677028	EA	1
21	5120-00-265-7462	Hammer, Hand Sledge, Double-Faced, 6 lbs, Type X, Class 1 (88728) 84H	EA	1

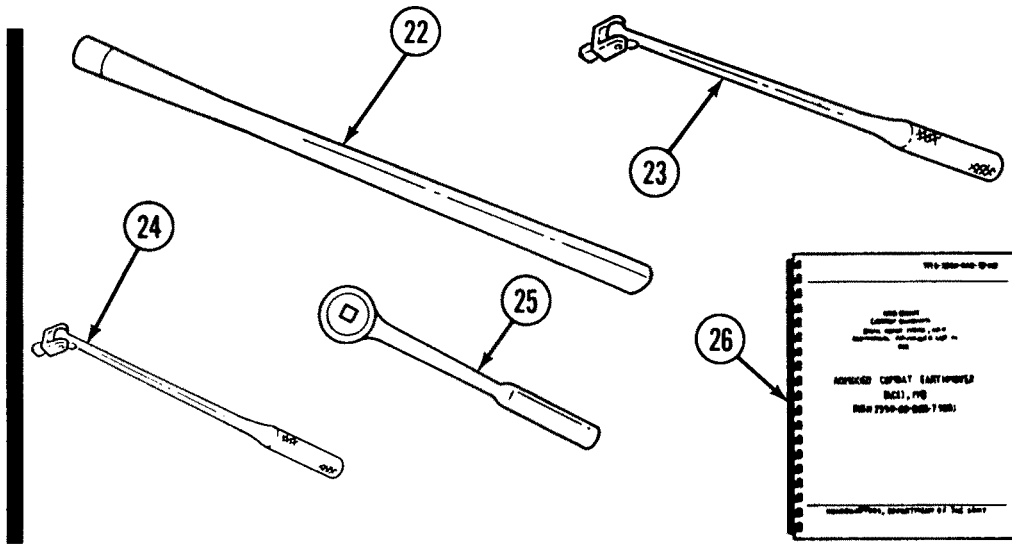

Section III. BASIC ISSUE ITEMS – CONTINUED

(1) Illus Number	(2) National Stock Number	(3) Description CAGEC and Part Number	Usable On Code	(4) U/M	(5) Qty Rqr
22	5120-00-288-6574	Handle, Mattock-Pick, Hickory, Type V, Class 1, Grade B, 36 in. Long (19207) 11677021		EA	1
23	5120-00-236-7590	Handle, Socket Wrench, Hinged, 1/2 in. Square Drive, Type III, Class 1, 18 in. Long (19207) 11655786-1		EA	1
24	5120-00-221-7959	Handle, Socket Wrench, Hinged, 3/4 in. Square Drive, Type III, Class 1, 20-1/2 in. Long (45225) H377		EA	1
25	5120-00-230-6385	Handle, Socket Wrench, Reversible Ratchet, 1/2 in. Drive, 9-1/2 in. Long (18876) 8528574		EA	1
26		Hand Receipt Manual TM 5-2350-262-10-HR		EA	1

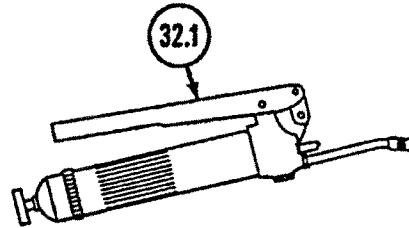
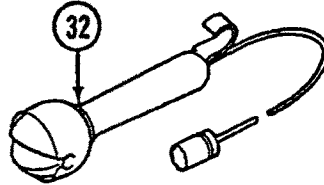
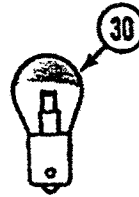

Section III. BASIC ISSUE ITEMS -- CONTINUED

(1) Illus Number	(2) National Stock Number	(3) Description CAGEC and Part Number	Usable On Code	(4) U/M	(5) Qty Rqrd
27		Deleted			
28		Deleted			
29	5120-00-198-5390	Key, Socket-Head Screw, 4-1/2 in. Long, 3/8 in. Hex (80064) 1940722 (For dozer latches removal and installation)		EA	1
30	6240-00-155-8725	Lamp, Incandescent (08806) 1204 (Extension light spare lamp)		EA	1
31		Deleted			
32	6230-00-558-5880	Light, Extension, 180 in. Wiring, 3.906 in. Long, 2.094 in. Diameter, 1 Bayonet Plug, Double-Contact Terminal, Open-End Guard with Hook (13445) DL16C		EA	1
32.1	4930-00-253-2478	Lubricating, Gun, Hand- Lever Operated (81349) M3859/1-14		EA	1

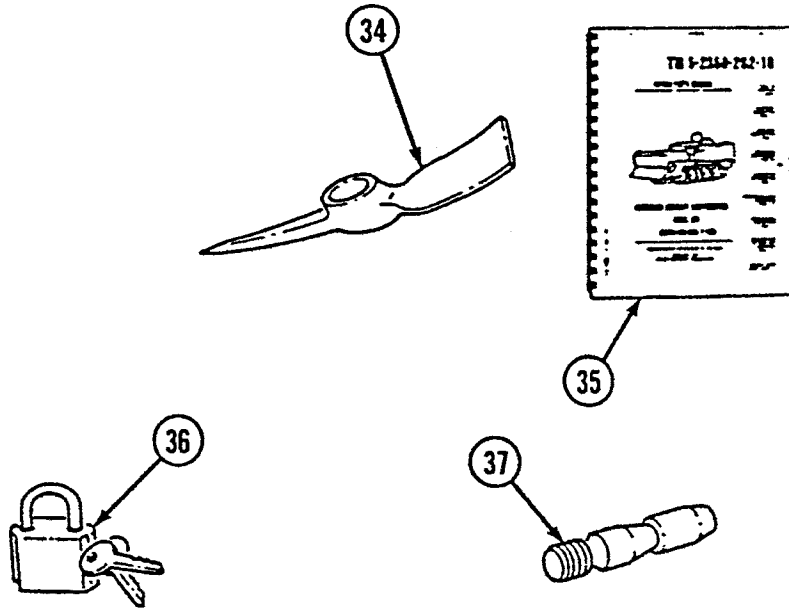

Section III. BASIC ISSUE ITEMS – CONTINUED

(1) Illus Number	(2) National Stock Number	(3) Description CAGEC and Part Number	Usable On Code	(4) U/M	(5) Qty Rqr
33		Deleted			
34	5120-00-243-2395	Mattock, 5 Pound, Type II, Class 5, w/o Handle (19207) 11677022		EA	1
35		Operator's Manual TM 5-2350-262-10		EA	1
36	5340-00-912-4086	Padlock Set (Set of 5) (96906) MS21313-160 (For ejector stowage box)		EA	1
37	5315-01-186-7991	Pin, Straight, Knurled, Alignment, Armor (19207) 12332340		EA	6

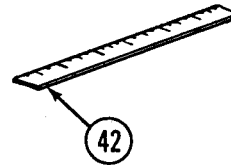
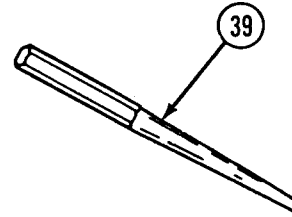
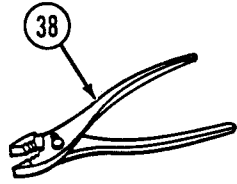

Section III. BASIC ISSUE ITEMS – CONTINUED

(1) Illus Number	(2) National Stock Number	(3) Description CAGEC and Part Number	(4) Usable On Code	(5) Qty Rqr
38	5120-00-223-7396	Pliers, Slip Joint (80244) GGG-P-471 TY2CL2STA	EA	1
39	5120-00-293-3509	Punch, Center, Solid (80244) GGG-P-831 TY2CLA	EA	1
40	Deleted			
41	Deleted			
42	5210-00-182-9656	Rule, Steel, Machinist's, 1/64 in. to 1/32 in. Graduated Edges, 6 in. Long, 7/32 in. Wide, 3/64 in. Thick (08871) 7305-006 (To measure track adjustment)	EA	1

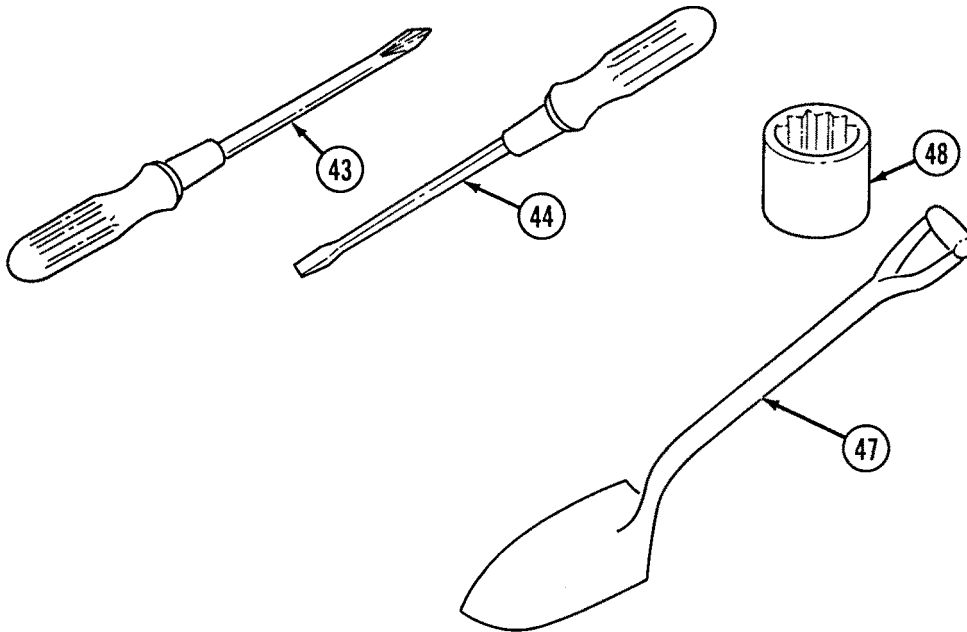

Section III. BASIC ISSUE ITEMS – CONTINUED

(1) Illus Number	(2) National Stock Number	(3) Description CAGEC and Part Number	(4) Usable On Code U/M	(5) Qty Rqr
43	5120-00-234-8912	Screwdriver, Cross Tip, 6 in. (55719) SSDP630	EA	1
44	5120-00-278-1283	Screwdriver, Flat Tip, 5/16 in. x 6 in. (19207) 41S1104	EA	1
45	Deleted			
46	Deleted			
47	5120-00-293-3336	Shovel, Hand, Type IV, Class A, Style 1, Size 2 (19207) 11655784	EA	1
48	5120-00-242-3349	Socket, Socket Wrench, 1/2 in. Drive, 12 Pt, 3/4 in. Opening (65814) SD-1224 (For armor removal and installation)	EA	1

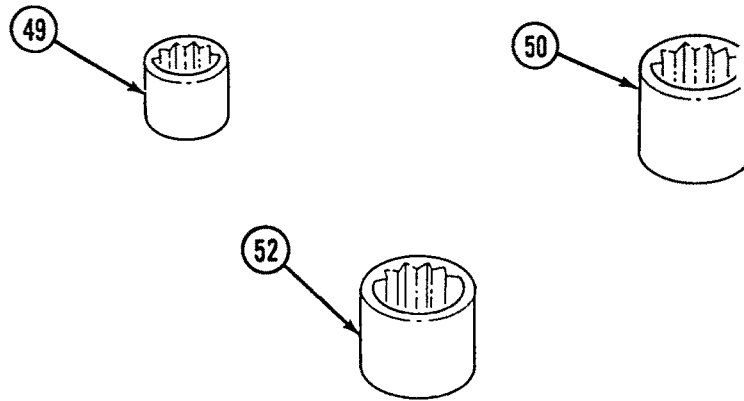

Section III. BASIC ISSUE ITEMS – CONTINUED

(1) Illus Number	(2) National Stock Number	(3) Description CAGEC and Part Number	Usable On Code	(4) U/M	(5) Qty Rqr
49	5120-00-189-7932	Socket, Socket Wrench, 1/2 in. Drive, 9/16 in. Opening (05506) ST-1218 (For apron lockpin screw)		EA	1
50	5120-00-189-7946	Socket, Socket Wrench, 1/2 in. Drive, 5/8 in. Opening (05506) ST-1220 (For final drive caps removal)		EA	1
51		Deleted			
52	5120-00-239-0021	Socket, Socket Wrench, 12 Pt, Reg L, 3/4 in. Drive, 1-1/8 in. Opening, Thin Wall, Type II, Class 2, Style A (80244) GGG-W-641TY2CL2STA (For armor removal and installation, track pad nut removal, and tightening nuts on dozer and scraper cutting edges)		EA	1

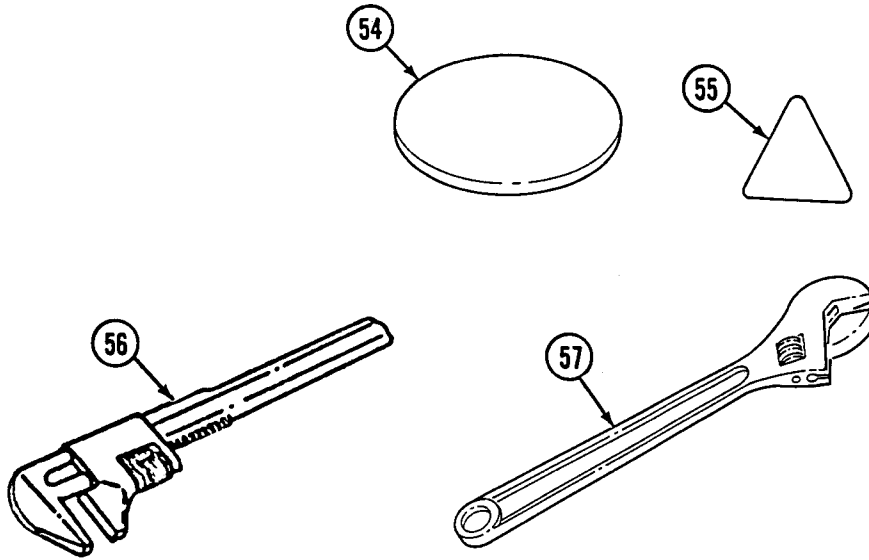

Section III. BASIC ISSUE ITEMS – CONTINUED

(1) Illus Number	(2) National Stock Number	(3) Description CAGEC and Part Number	Usable On Code	(4) U/M	(5) Qty Rqr
53		Deleted			
54	5365-01-186-8009	Spacer, Plate (97403) 13211E8658 (Use to hold final drive components apart when disconnected)		EA	2
55	9905-00-534-8376	Warning Device Kit (80372) 8K388		EA	1
56	5210-00-264-3793	Wrench, Adjustable, 3-5/8 in. Jaw Opening, 14-1/2 in. Long (24617) 2117080 (To remove hydraulic tank fill plug)		EA	1
57	5120-00-449-8083	Wrench, Adjustable, Single-Head Type, 1-1/8 in. Jaw Opening, 10 in. Long (15073) 5385A14		EA	1

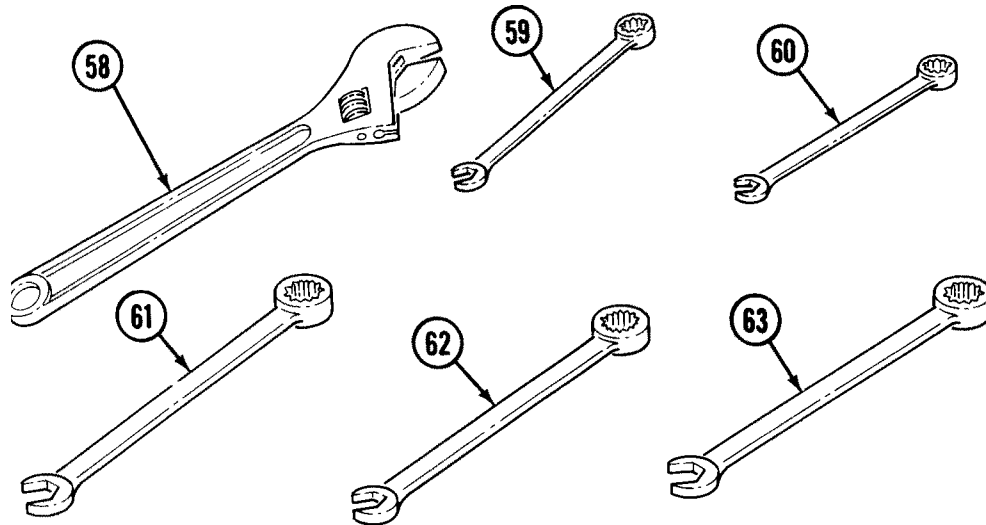

Section III. BASIC ISSUE ITEMS – CONTINUED

(1) Illus Number	(2) National Stock Number	(3) Description CAGEC and Part Number	(4) Usable On Code U/M	(5) Qty Rqr
58	5120-00-423-6728	Wrench, Adjustable, Single-Head Type, 1.698 in. Jaw Opening, 15 in. Long (19207) 6187328	EA	1
59	5120-00-228-9509	Wrench, Box and Open-End Combination, .69, 11/16 in. (07971) 1165 (For tightening hydraulic fittings)	EA	1
60	5120-00-228-9510	Wrench, Box and Open-End Combination, .75, 3/4 in. (05506) 1166 (For tightening hydraulic fittings)	EA	2
61	5120-00-228-9512	Wrench, Box and Open-End Combination, .88, 7/8 in. (05506) 1167 (For tightening hydraulic fittings)	EA	1
62	5120-00-228-9513	Wrench, Box and Open-End Combination, .94, 15/16 in. (65814) 1168 (For tightening hydraulic fittings)	EA	1
63	5120-00-228-9514	Wrench, Box and Open-End Combination, 1.00, 1 in. (65814) 1170 (For tightening hydraulic fittings)	EA	1

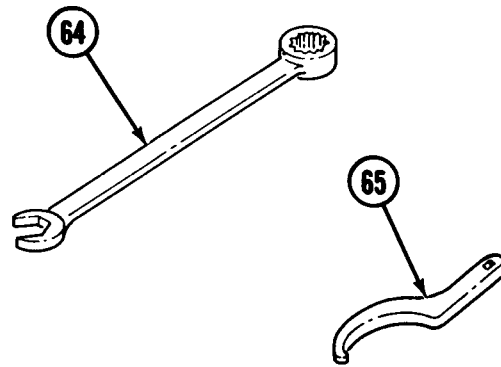

Section III. BASIC ISSUE ITEMS – CONTINUED

(1) Illus Number	(2) National Stock Number	(3) Description CAGEC and Part Number	(4) Usable On Code	(5) Qty Rqr
64	5120-00-228-9517	Wrench, Box and Open-End Combination 1.25, 1-1/4 in. Type III (05506) 1173 (For tightening hydraulic fittings)	EA	1
65	5120-01-229-9134	Wrench, Spanner (19207) 12355454 (To disconnect final drives)	EA	1

APPENDIX C
ADDITIONAL AUTHORIZATION LIST

Section I. INTRODUCTION

C-1. SCOPE

This appendix lists additional items authorized for the support of the M9.

C-2. GENERAL

This list identifies items that do not have to accompany the M9 and that do not have to be turned in with it. These items are all authorized by CTA, MTOE, TDA, or JTA.

C-3. EXPLANATION OF LISTING

National stock number, descriptions, and quantities are provided to help identify and request the additional items required to support this equipment. The items are listed in alphabetical sequence by item name under the type of document (i.e., CTA, MTOE, TDA, or JTA) which authorizes the item(s).

Section II. ADDITIONAL AUTHORIZATION LIST

(1) National Stock Number	(2) Description CAGEC and Part Number	(3) Usable On Code U/M	(4) Qty Auth
5985-00-985-9024	Antenna, AS-1729/VRC (80063) SM-D-542001	EA	1
1040-01-095-0092	Arming Firing Unit (81361) E13-12-111	EA	1
8465-01-117-8699	Bag, Duffel (81349) MIL-B-829	EA	1
2540-01-096-4559	Box, Accessories Stowage (81361) D13-12-40	EA	1
1080-00-103-1246	Camouflage Screening System (97403) 13226E1359	EA	2
7240-00-242-6153	Can, Water, Military, 5 Gallon (19207) 11655980	EA	1
5340-01-095-0297	Cap-Plug, Protective, Dust and Moisture Seal (81361) C13-12-65	EA	8
1240-00-137-7768	Case, Optical Instrument, Night Vision Goggles (80063) SM-D-657440	EA	1
4230-01-133-4124	Decontaminating Apparatus, M13 (81361) E5-51-527	EA	1
6665-01-016-8399	Detector Kit, Chemical Agent, M256 (81361) C5-77-2001	EA	1
1040-01-095-0091	Discharger, Smoke (81361) E13-12-90	EA	2
6230-00-161-6422	Flashlight (80064) 1833245	EA	1
8340-01-021-5978	Footwear Covers, Chemical Protective (81349) MIL-F-43987	EA	1
8415-01-033-3519	Glove Set, Chemical Protective, Large (81349) MIL-G-43976	EA	1
OR			

Section II. ADDITIONAL AUTHORIZATION LIST – CONTINUED

(1) National Stock Number	(2) Description CAGEC and Part Number	(3) Usable On Code U/M	(4) Qty Auth
8415-01-033-3518 OR	Glove Set, Chemical Protective, Medium (81349) MIL-G-43976	EA	1
8415-01-033-3517	Glove Set, Chemical Protective, Small (81349) MIL-G-43976	EA	1
8415-00-268-7859	Gloves, Welder's (58536) A-A-50022	EA	1
5855-00-150-1820 OR	Goggles, Image Intensifier; Night Vision (80058) AN/PVS-5	EA	1
5855-00-228-0937	Goggles, Image Intensifier; Night Vision (80058) AN/PVS-7B	EA	1
1330-01-124-5031	Grenade, Launcher, Smoke, L8A3 (81361) B13-19-133	EA	8
8470-01-130-3795 OR	Helmet, CVC, Large (81349) MIL-H-44117	EA	1
8470-01-130-3794 OR	Helmet, CVC, Medium (81349) MIL-H-44117	EA	1
8470-01-130-8180	Helmet, CVC, Small (81349) MIL-H-44117	EA	1
4240-00-860-8987	Hood, Chemical-Biological Mask, M5 (81349) MIL-H-51143	EA	1
2590-01-224-9241	Jack, Roadwheel (19207) 12355582	EA	2
4230-00-123-3180	Kit, Skin Decontamination, M258 (81361) D5-77-2150	EA	1
1055-01-107-7501	Launcher, Grenade (81361) B13-12-150	EA	1
4240-00-994-8752 OR	Mask, Chemical-Biological, Large (81361) 5-1-325-30	EA	1
4240-00-994-8750 OR	Mask, Chemical-Biological, Medium (81361) 5-1-325-20	EA	1
4240-00-994-8751 Deleted	Mask, Chemical-Biological, Small (81361) 5-1-325-10 Deleted	EA	1

Section II. ADDITIONAL AUTHORIZATION LIST – CONTINUED

(1) National Stock Number	(2) Description CAGEC and Part Number	(3) Usable On Code U/M	(4) Qty Auth
5340-00-158-3807	Padlock (96906) MS35647-9	EA	3
6665-01-049-8982	Paper, Chemical Agent Detector (81361) D5-67-271	EA	1
5315-01-156-6208	Pin, Straight, Headed (97403) 13211E9226	EA	2
1005-00-726-5655	Pistol, M1911A1, .45 Cal. (19200) 7265655	EA	1
5810-01-026-9621	Power Supply, Veh HYP 57KSEC (98230) ON241780	EA	1
5820-01-151-9916	Radio Set, (SINGARS) AN/VRC-87 (80063) A3080234-1	EA	1
5820-00-223-7475	OR Radio Set, AN/VRC-64 (80063) PPL4324	EA	1
5810-00-434-3644	Speech Equipment (98230) ON241700	EA	1
2590-01-228-5802	Stand Vehicle Support (19207) 12355345	EA	4
8415-00-407-1062	Suit, Chemical Protective, Large (81349) MIL-S-43926B	EA	1
OR			
8415-00-177-5008	Suit, Chemical Protective, Medium (81349) MIL-S-43926B	EA	1
OR			
8415-00-177-5007	Suit, Chemical Protective, Small (81349) MIL-S-43926B	EA	1
1080-00-108-1173	Support, Camouflage Screening System (12193) 170177	EA	2
	Deleted		
	Deleted		
8415-01-217-5634	Vest, Microclimatic (81337) 2-11-1	EA	1

APPENDIX D

EXPENDABLE SUPPLIES AND MATERIALS LIST

Section I. INTRODUCTION

D-1. SCOPE

This appendix lists expendable supplies and materials needed to operate and maintain the M9. These items are authorized by CTA 50-970, Expendable Items (except Medical, Class V, Repair Parts, and Heraldic Items).

D-2. EXPLANATION OF COLUMNS

- a. Column (1) — Item Number. This number is assigned to the entry in the listing for reference only.
- b. Column (2) — Level. This column identifies the lowest level of maintenance that requires the listed item.

(enter as applicable)

C — Operator/Crew
O — Unit Maintenance
F — Direct Intermediate Support Maintenance
H — Intermediate General Support Maintenance

- c. Column (3) — National Stock Number. This is the National stock number assigned to the item; use it to request or requisition the item.
- d. Column (4) — Description. Indicates the Federal item name and, if required, a description to identify the item. The last line for each item indicates the Federal Supply Code for Manufacturer (FSCM), in parentheses.
- e. Column (5) — Unit of Measure (U/M). Indicates the measure used in performing the actual maintenance function. This measure is expressed by a two- or three-character alphabetical abbreviation (e.g., oz, gal.). If the unit of measure differs from the unit of issue, requisition the lowest unit of issue that will satisfy the requirements.

Section II. EXPENDABLE SUPPLIES AND MATERIALS LIST

(1) Item Number	(2)	(3) National Stock Number	(4) Description	(5) U/M
1	C	6850-00-181-7929	Antifreeze, Permanent, Glycol, Inhibited (81349) MIL-A-46153 1 gal. container	gal.
		6850-00-174-1806	Antifreeze, Arctic-Type (81349) MIL-A-11755 55 gal. drum	gal.
1.1	C	4220-00-372-0585	Cartridge, Carbon, Type 1 (81349) MIL-C-25369	ea
2	C	9150-01-054-6453 9150-01-053-6688	Cleaner, Lubricant, A (81349) MIL-L-63460 1 pt container 1 gal. container	pt gal.
3	C	6850-00-224-6657 6850-00-224-6663	Compound, Cleaning, Solvent: Rifle Bore Cleaner, RBC (81349) MIL-C-372 8 oz. container 1 gal. container	gal. gal.
4	C	9130-01-305-5597	Turbine Fuel, Aviation JP-8, NATO F-34 (81349) MIL-T-83133	gal.
5	C	9150-00-065-0029 9150-00-190-0904 9150-00-190-0905 9150-00-190-0907	Grease, Automotive and Artillery, GAA (81349) MIL-G-10924 2-1/4 oz tube 1-3/4 lb can 6-1/2 lb can 35 lb can	oz lb lb lb
6	O		Lubricant, Gear, Universal (MIL-L-2106)	
7	C	9140-00-286-5286 9140-00-286-5287 9140-00-286-5288 9140-00-286-5289	Oil, Fuel, Diesel, DF-1, Winter (81348) VV-F-800 Bulk 5 gal. can 55 gal. drum, 16 gage 55 gal. drum, 18 gage	gal. gal. gal. gal.

Section II. EXPENDABLE SUPPLIES AND MATERIALS LIST – CONTINUED

(1) Item Number	(2)	(3) National Stock Number	(4) Description	(5) U/M
8	C	9140-00-286-5294 9140-00-286-5295 9140-00-286-5296 9140-00-286-5297	Oil, Fuel, Diesel, DF-2, Regular (81348) VV-F-800 Bulk 5 gal. drum 55 gal. drum, 16 gage 55 gal. drum, 18 gage	gal. gal. gal. gal.
9	C	9140-00-286-5283 9140-00-286-5282 9140-00-286-5284	Oil, Fuel, Diesel, DF-A, Arctic (81348) VV-F-800 Bulk 5 gal. drum 55 gal. drum	gal. gal. gal.
10	C	9150-01-035-5390 9150-01-035-5391	Lubricating Oil, Gear (81349) MIL-L-2105 1 qt can 5 gal. drum	qt gal.
11	C	9150-01-035-5392 9150-01-035-5393	Lubricating Oil, Gear (81349) MIL-L-2105 1 qt can 5 gal. drum	qt gal.
12	C	9150-01-035-5392 9150-01-035-5395	Oil, Gear, Multipurpose GO 85/140 (81349) MIL-L-2105 1 qt can 5 gal. drum	qt gal.
13	C	9150-00-234-5197 9150-00-261-7891	Oil, Lubricating, Chain, Wire Rope, and Exposed Gear CW-11A (81348) VV-L-751 5 lb can 35 lb can	lb lb

Section II. EXPENDABLE SUPPLIES AND MATERIALS LIST – CONTINUED

(1) Item Number	(2)	(3) National Stock Number	(4) Description	(5) U/M
14	C	9150-00-234-5199 9150-00-246-3276	Oil, Lubricating, Chain, Wire Rope, and Exposed Gear CW-11B (81348) VV-L-751 5 lb can 35 lb can	lb lb
15	C	9150-00-234-5200 9150-00-264-2918	Oil, Lubricating, Chain, Wire Rope, and Exposed Gear CW-11C (81348) VV-L-751 5 lb can 35 lb can	lb lb
16	O	9150-01-035-5390 9150-00-257-5440 9150-00-257-5443	Oil, Lubricating, Gear, Subzero, GOS (81349) MIL-L-10324 1 qt can 5 gal. can 55 gal. drum	qt gal. gal.
17	C	9150-00-189-6727 9150-00-186-6668 9150-00-191-2772	Oil, Lubricating, OE/HDO 10 (81349) MIL-L-2104 1 qt can 5 gal. can 55 gal. drum, 18 gage	qt gal. gal.
18	C	9150-00-186-6681 9150-00-188-9858 9150-00-189-6729	Oil, Lubricating, OE/HDO 30 (81349) MIL-L-2104 1 qt can 5 gal. can 55 gal. drum, 18 gage	qt gal. gal.

Section II. EXPENDABLE SUPPLIES AND MATERIALS LIST – CONTINUED

(1) Item Number	(2)	(3) National Stock Number	(4) Description	(5) U/M
19	C	9150-00-188-9864 9150-00-188-9865 9150-00-188-9867	Oil, Lubricating, OE/HDO 50 (81349) MIL-L-2104 1 qt can 5 gal. can 55 gal. drum, 16 gage	qt gal. gal.
20	O	9150-00-402-4478 9150-00-402-2372 9150-00-491-7197	Oil, Lubricating, OEA ICE, Subzero (81349) MIL-L-46167 U/I 1 qt can 5 gal. can 55 gal. drum, 16 gage	qt gal. gal.
21	C	9150-00-231-6689	Oil, Lubrication: General Purpose, Preservative, PL-S (81348) VV-L-800 1 qt can	qt
22	C	9150-00-231-2361	Oil, Lubrication: General Purpose Preservative, PL-M (81349) MIL-L-3150 1 qt can	qt
23	C	7930-00-634-5340	Polish, Plastic (77247) 4030	pt
24	C	6850-00-664-5685 6850-00-281-1985	Drycleaning Solvent (81348) P-D-680 1 qt can 1 gal. can	qt gal.

APPENDIX E

STOWAGE AND SIGN GUIDE

E-1. SCOPE

This appendix shows the locations for stowage of equipment and materiel required to be carried on the M9.

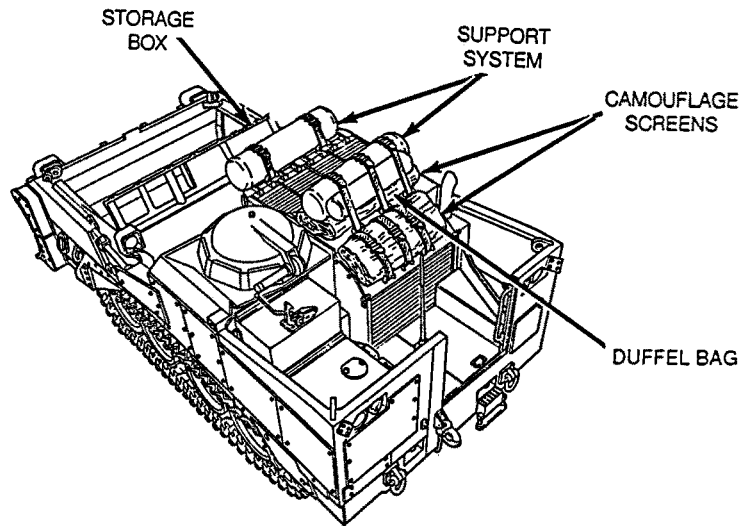
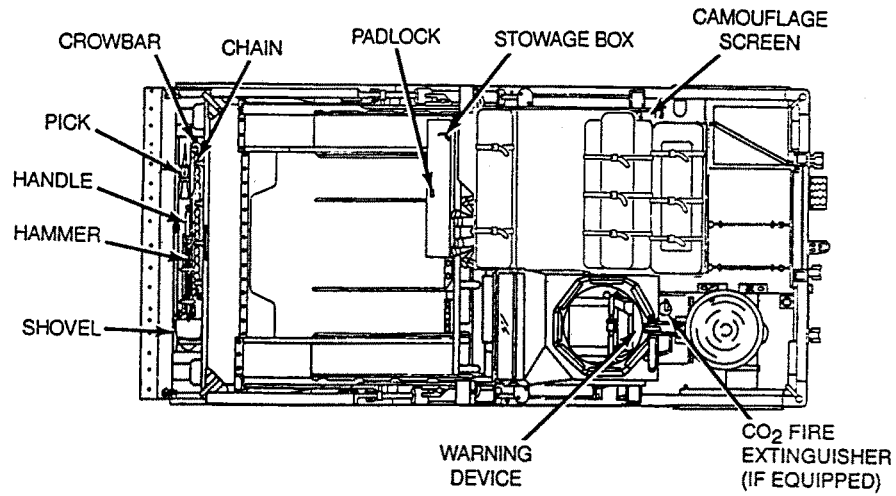

STOWAGE AND SIGN GUIDE — CONTINUED

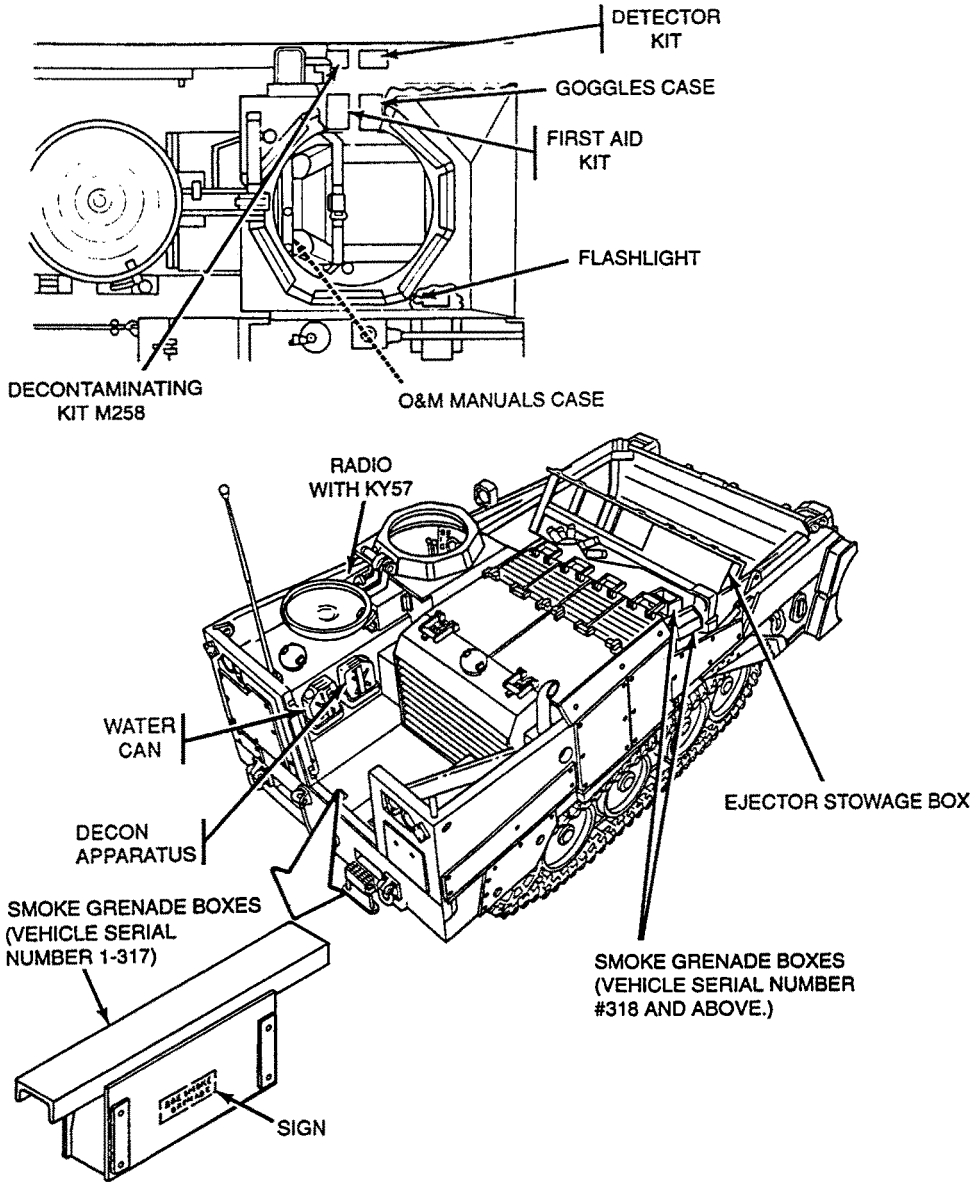

APPENDIX F

LUBRICATION INSTRUCTIONS

F-1. SCOPE

This appendix gives lubrication requirements for the M9 ACE series vehicles which are the responsibility of the operator/crew.

F-2. GENERAL LUBRICATION REQUIREMENTS

This lubrication is divided based on lubrication intervals (daily, monthly, quarterly, semiannually, annually, and on-condition).

MAN-HOUR TIMES:

The man-hour time specified is the time required to perform all services at the particular interval.

LEVEL OF MAINTENANCE: C -- Operator

LUBRICATION POINTS:

Type of lubricants used at each point are identified by arrows:



OBSERVE THE FOLLOWING

- NEVER use the wrong type grease.
- NEVER use too much lubrication.
- ALWAYS clean grease fittings with drycleaning solvent (SD), type III or equivalent, and dry before lubricating.
- ALWAYS use the lubrication order.

An overall view showing lubrication points precedes each set of detailed notes.

A dash line (---) means the same lubrication points are on both sides of vehicle.

Intervals are based on normal operation.

- Lubricate more often during constant operation.
- Lubricate all items found contaminated after fording or high-pressure washing.
- On-condition intervals for oil changes shall be determined by the Army Oil Analysis Program (AOAP) laboratory and shall be applied unless otherwise notified. See p F-5 for oil sampling procedures.
- Oil filters shall be changed at prescribed hard time intervals or sooner when:
 - a. They are known to be contaminated or clogged;
 - b. Service is recommended by AOAP laboratory analysis.

TM 5-2350-262-10

- For equipment under manufacturer's warranty, hard time oil service intervals shall be followed. Intervals shall be shortened if lubricants are known to be contaminated or if operation is under adverse conditions (such as longer-than-usual operating hours, extended idling periods, extreme dust).
- For operation of vehicle in prolonged cold temperatures below -10°F (-23°C), remove lubricants prescribed in the key for temperatures above -10°F (-23°C), clean parts with drycleaning solvent (SD-3), and relubricate with lubricants specified in the key for temperatures 0°F to -65°F (-18°C to -54°C).
- Operation in dusty or sandy areas will require more frequent cleaning and servicing of filters to prevent dust from entering engine, transmission, steer unit, and hydraulic system.

WARNING: Drycleaning solvent is flammable and will not be used near open flame. A fire extinguisher will be kept nearby when the solvent is used. Use only in well-ventilated areas. Failure to comply may result in damage to equipment or injury to personnel.

KEY						
LUBRICANTS		CAPACITIES		EXPECTED TEMPERATURES		
				+32°F and above (0°C and above)	-10° to +40°F (-23° to 4°C)	0° to -65°F (-18° to -54°C)
OE/HDO (MIL-L-2104)	LUBRICATING OIL, Internal Combustion Engine Tactical Service			OE/HDO-30	OE/HDO-10	CEA
OEA (MIL-L-46167)	LUBRICATING OIL, Internal Combustion Engine Arctic					
	Engine Crankcase, add 4 additional quarts (3.8 L) for filters	Refill 22 qts (20.8 L) Dry 30 qts (28.4 L)				
	Winch 25,000 Lb (11,350 Kg) 35,000 Lb (15,890 Kg)	3.5 qts (3.3 L) 4.0 qts.(3.8 L)		OE/HDO-10	OE/HDO-10	CEA
	Transmission, Steer Unit, Transfer Case, Oil Cooler and Lines	Refill 50 qts (47.3 L) Dry 78 qts (73.8 L)				
	Hydraulic Tank	Refill 108 qts (102.2 L) Dry 128 qts (121.1 L)				
	Hydraulic Tank Return Line Filter	4 qts (3.8 L)				
GO (MIL-L-2105)	LUBRICATING OIL, Gear, Multi-purpose			GO-80/90		
	Final Drives (2)	2 gal. each (7.6 L)				
GAA (MIL-G-10924)	GREASE, Automotive and Artillery			GAA		
	Roadwheel Hub Bearing					
GMD (MIL-G-21164)	Molybdenum Disulfide			GMD		
	Hatch Hinge Assembly					
	Prop Shaft					
PL (Medium MIL-L-3150) (Special VV-L-800)	LUBRICATING OIL, General Purpose Oil Can Points			PL-M Medium	PL-S Special	PL-S Special
GENERAL NOTE 1		If OEA lubricant is required to meet the temperature ranges specified in key, OEA is to be used in all places where OE/HDO-10 is specified.				
GENERAL NOTE 2		The use of OE/HDO 15W-40 in lieu of OE/HDO-30 is authorized. The OE/HDO 15W-40 can be used at all temperatures above +5°F (-15°C) for all components except the transmission, transfer case, steer unit, and final drives.				

— KEY —			
LUBRICANTS	CAPACITIES	EXPECTED TEMPERATURES	
		+32°F and above (0°C and above)	-10° to +40°F (-23° to 4°C)
(MIL-L-G18458) GREASE, WIRE ROPE		MIL-G-18458	
Winch Cable and Drum			

FUEL REQUIREMENTS TEMPERATURE LIMITS (VV-F-800)

Grade DF-2 Fuel For use above +10°F (-12°C)*

Grade DF-1** For use below +10°F (-12°C) to above -20°F (-29°C)

Grade DF-A For use below -20°F (-29°C)

Grade JP8 For use above -60°F (-51°C)

* Usage temperature may vary dependent on the cloud point of the actual DF-2 fuel being supplied in the geographical area.

** DF-1 is not normally procured in CONUS or OCONUS. Refineries will blend DF-2 with kerosene to meet temperature requirements of DF-1.

INTERVALS

<p>D-Daily</p> <p>M-Monthly or 33 hours of operation, whichever occurs first.</p> <p>Q-Quarterly (3 months) or 100 hours of operation, whichever occurs first.</p>	<p>S-Semiannually (6 months) or 200 hours of operation, whichever occurs first.</p> <p>A-Annually (12 months) or 400 hours of operation, whichever occurs first.</p> <p>OC-On-condition.</p>
---	---

TOTAL MAN-HOURS		TOTAL MAN-HOURS	
INTERVAL MAN-HOURS		INTERVAL MAN-HOURS	
D	0.3	S	2.8
M	1.0	A	4.5
Q	3.7	OC	1.0

OIL ANALYSIS PROGRAM SAMPLING PROCEDURES

Note

Oil samples must be submitted to an assigned Army Oil Analysis Program (AOAP) laboratory in accordance with DA Pam 738-750.

Three oil sampling valves (1) are located on the oil sampling manifold (2). The valves are identified by the plate (3) above the valves (1), and are used to sample oil from the following:

- | | | |
|----------------|-----|---|
| HYDRAULIC OIL | — — | Samples oil from the vehicle hydraulic system. |
| ENGINE OIL | — — | Samples vehicle engine oil. |
| POWERTRAIN OIL | — — | Samples lubricating oil from the transmission, steer unit, and transfer case. |

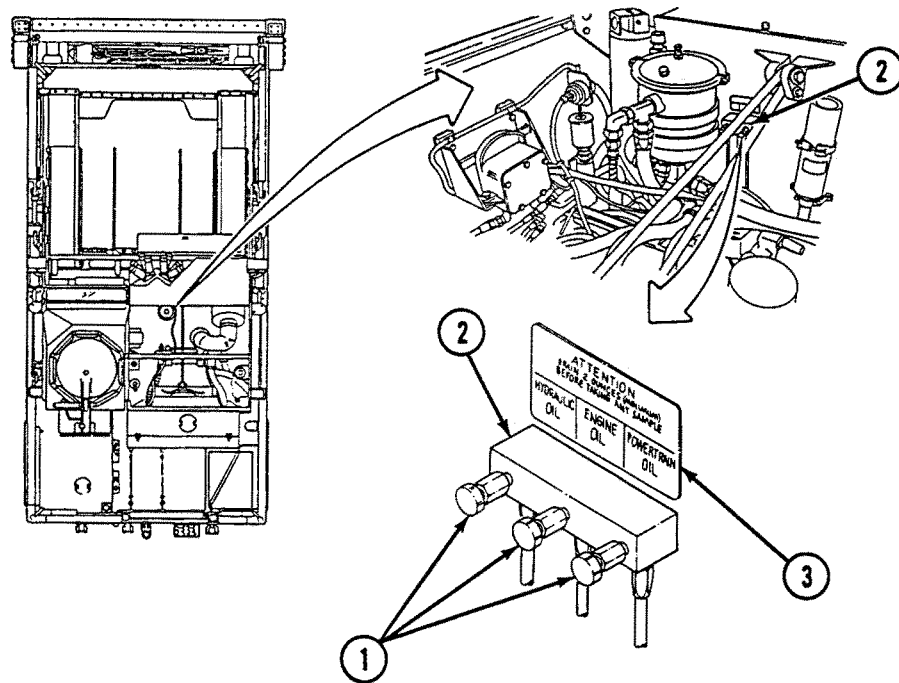

OIL ANALYSIS PROGRAM SAMPLING PROCEDURES (CONTINUED)

When a lubrication note specifies that an oil sample must be taken, use the following procedure:

- A Open engine intake grilles.
- B Ensure that oil to be sampled is at its normal operating temperature.
- C Open valve (1) of system or component to be sampled, and drain at least 2 oz (59 ml) of oil into a container. Close valve (1), and discard this oil.
- D Place sample bottle under valve of system or component to be sampled, open valve (1), and fill sample bottle to approximately 1/2 in. (1.3 cm) below neck of bottle. Close valve (1).
- E Send oil sample to AOAP laboratory.
- F If no other tasks will be performed in the engine compartment, close engine intake grilles.

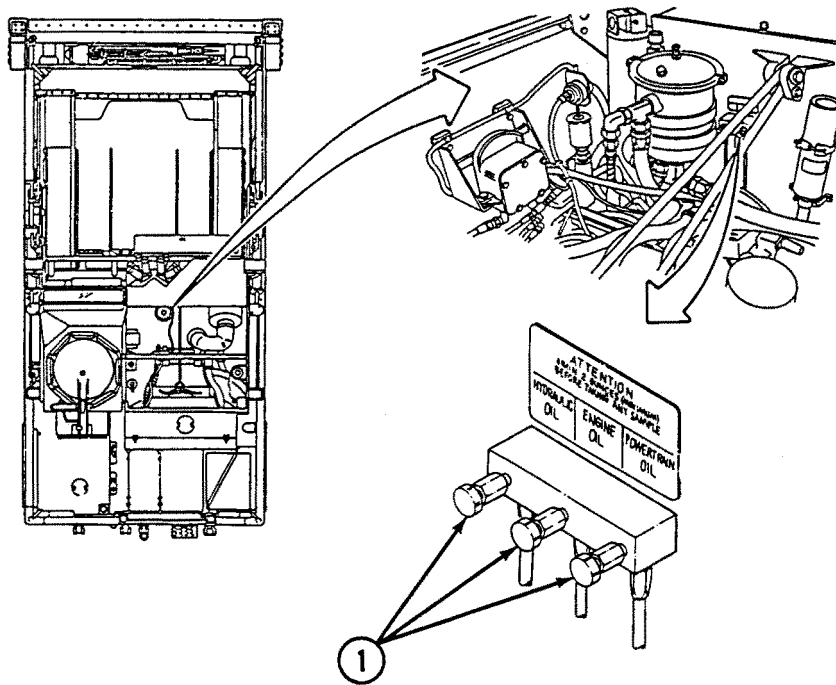

DAILY NOTES

LUBRICANT • INTERVAL

Engine
Crankcase
Level Check
(See Note 1) (C)

D

Engine
Crankcase
Fill
(See Note 1) (C)

OE/HDO
or
OEA

D

Hydraulic
Tank
Level Check
(See Note 3) (C)

D

Hydraulic
Tank Fill
(See Note 3) (C)

OE/HDO
or
OEA

D

Transmission,
Steer Unit,
and Transfer
Case Fill
and Level Check
(See Note 4) (C)

OE/HDO
or
OEA

D

Final Drive
Level Check
(See Note 2) (C)

D

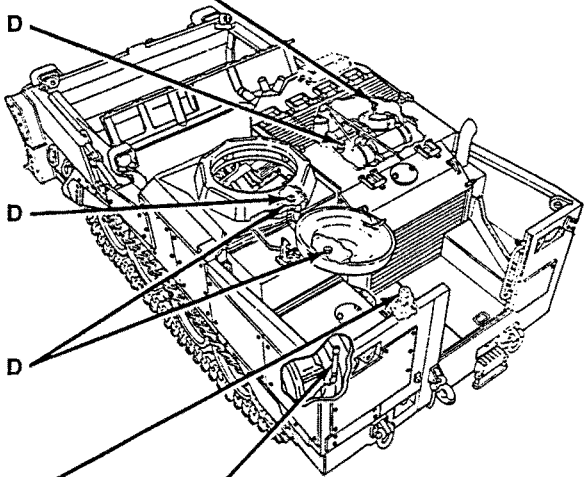

DAILY NOTES (CONTINUED)

Note 1

ENGINE CRANKCASE

Access through intake grilles.

- A Check oil level before starting engine.
- B Level should be between low (L) and high (H) marks on gauge (1).
- C Add or drain OE/HDO or OEA as required. To add oil, remove filler cap (2) from rocker cover. Install cap (2) when done filling oil.

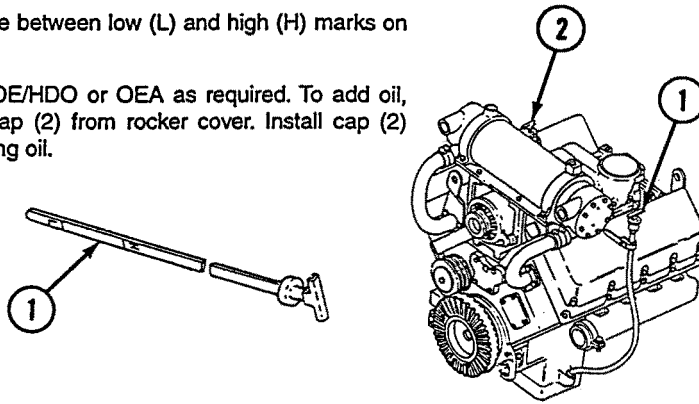

Note 2

FINAL DRIVE

Note

Check level when oil is hot.

- A Check level on gauge (1).
- B Level should be within flat area on gauge (1).
- C Add GO-80/90 through filler vent (2) as required.

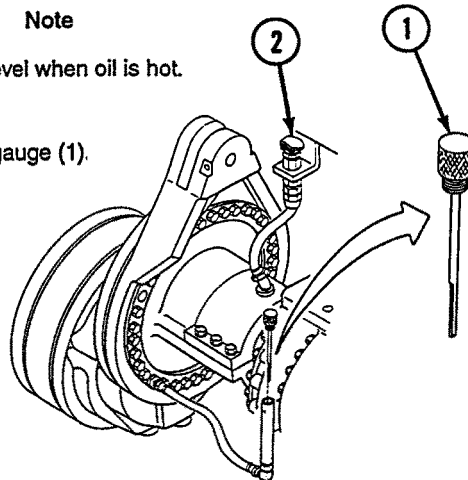

DAILY NOTES (CONTINUED)

Note 3

HYDRAULIC TANK

Note

Check hydraulic oil level with ejector retracted (back), apron down, and hydraulic pressure relieved.

Access through operator's hatch.

- A Check oil level on gauge (1).
- B Oil level should be within the FULL marks.
- C Add or drain OE/HDO-10 or OEA, as required. Add oil through either the primary fill point (2) or optional fill point (3).

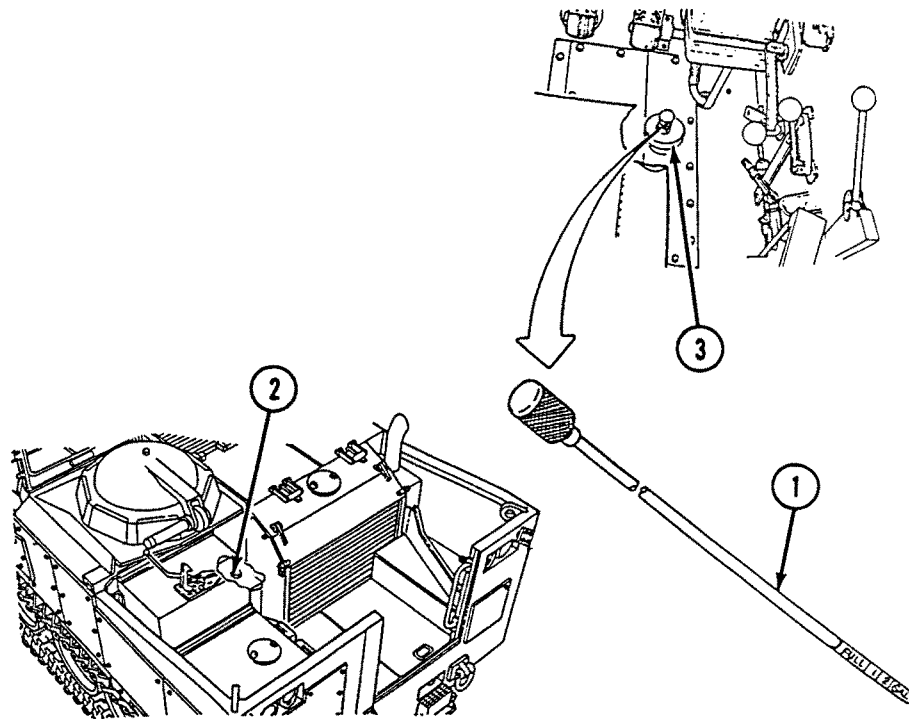

DAILY NOTES (CONTINUED)

Note 4

TRANSMISSION, STEER UNIT, AND TRANSFER CASE

Access through rear floor plates.

CAUTION

Do not overfill steer unit. Failure to comply may result in damage to equipment.

Note

- The level on the steer unit gauge is the level of all three units.
- Engine must be running.

- A** Start engine and run at idle speed (750 to 850 rpm) for 3 to 5 minutes.
- B** Check oil level on gauge (1). Oil level should be in COLD IDLE or OPERATING RANGE.
- C** Add oil, OE/HDO-10 or OEA, through fill point (2), as necessary. If over FULL mark when at COLD IDLE, drain excess oil.

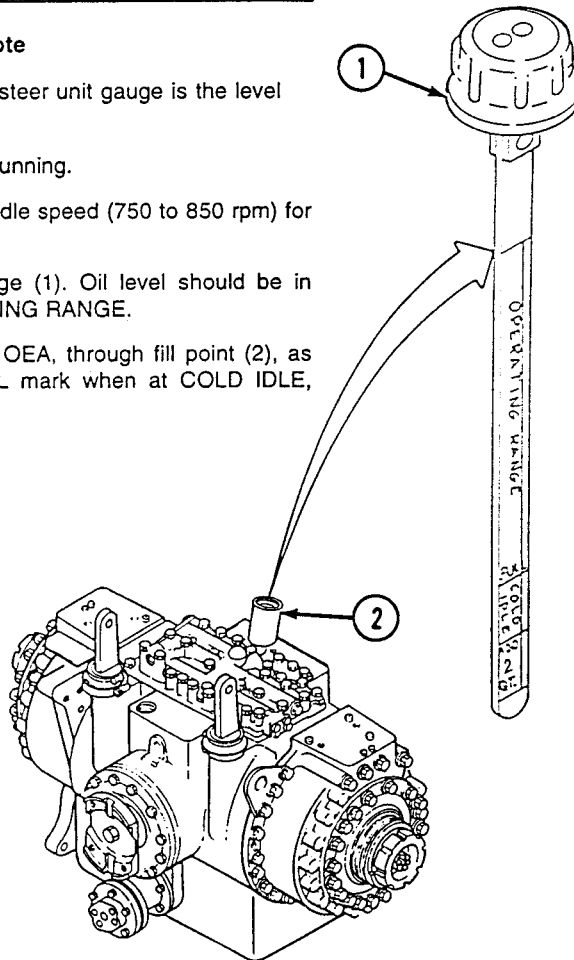

MONTHLY NOTES

LUBRICANT • INTERVAL

Roadwheel Hubs
(See Note 5) (C)

M

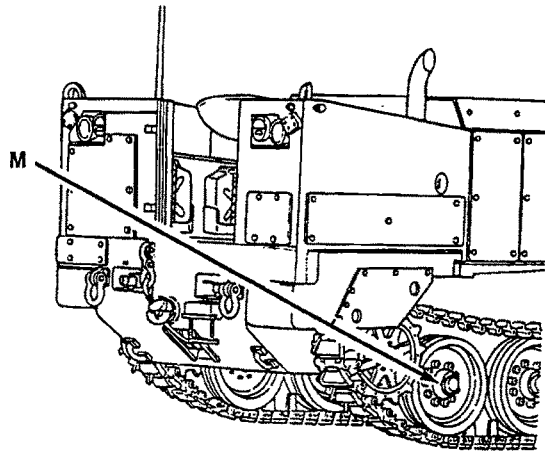

Note 5

ROADWHEEL HUBS

Note

Perform step A for new and step B for old roadwheel hub configuration.

- A Lubricate two fittings (1) with GAA until grease comes out of safety relief valve (2).
- B Lubricate fitting (3) with GAA until grease comes out of safety relief valve (4).

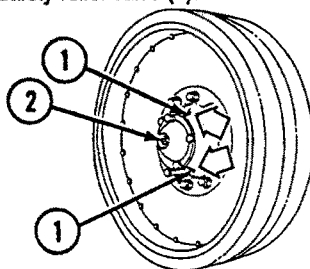

NEW CONFIGURATION

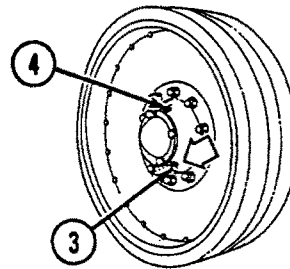

OLD CONFIGURATION

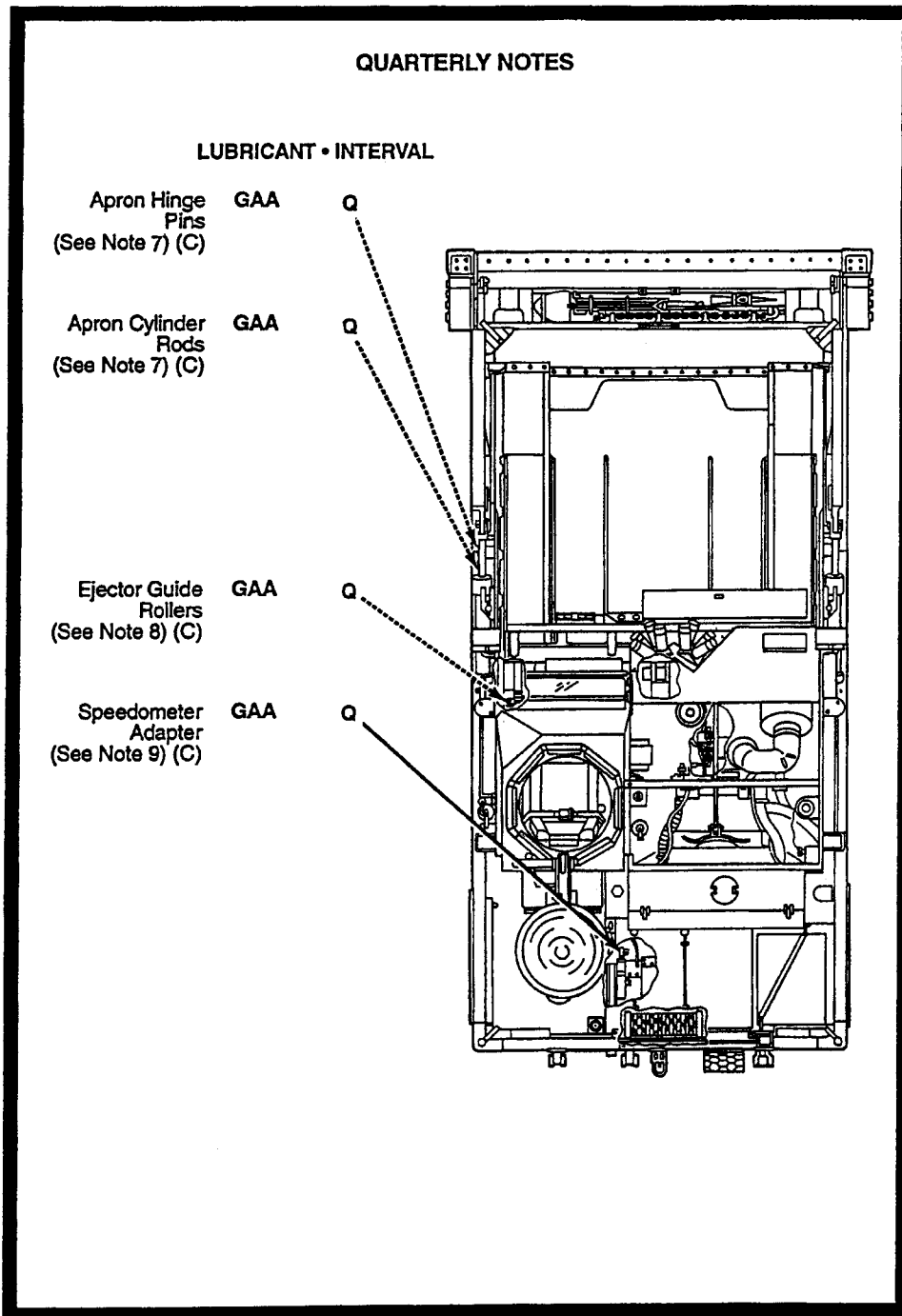

QUARTERLY NOTES (CONTINUED)

INTERVAL • LUBRICANT

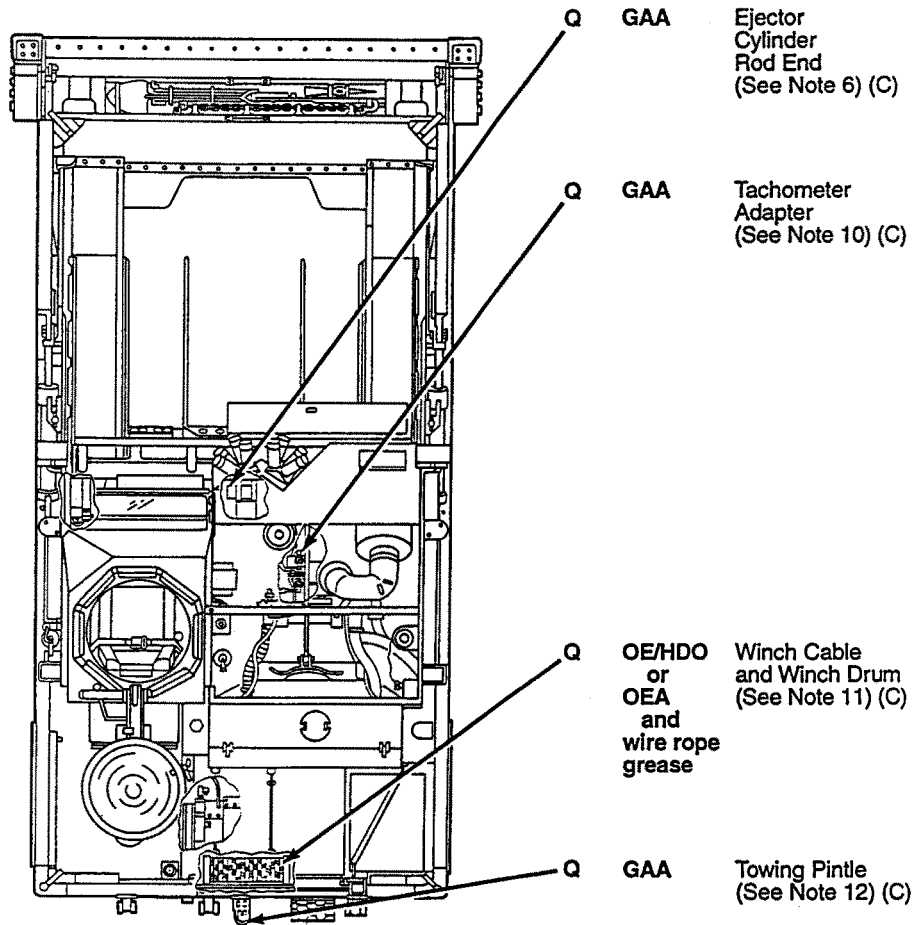

QUARTERLY NOTES (CONTINUED)

LUBRICANT • INTERVAL

Hydraulic Tank
Return Line Filter
(Refer to Unit
Maintenance) OE/HDO
or
OEA

Q

Transfer Case/
Steer Unit
Breather
(See Note 13) (O)

Q

Hydraulic
Tank Breather
(See Note 14) (O)

Q

Prop Shaft
(See Note 15) (O) GMD

Q

Hatch Cam
(See Note 16) (C) GMD

Q

Hatch Cam Roller
(See Note 17) (C) GAA

Q

Winch
Level Plug
(See Note 20) (C) GO-80/90

Q

Track Adjusting
Cylinder Pins
(See Note 18) (C) GAA

Q

DELETED

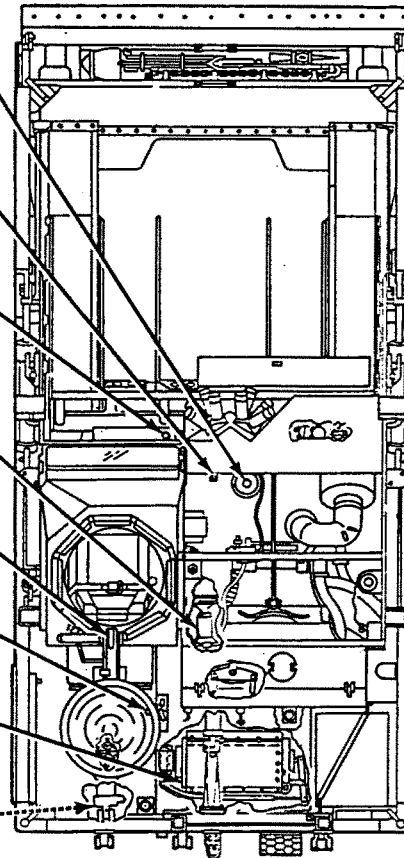

QUARTERLY NOTES (CONTINUED)

INTERVAL • LUBRICANT

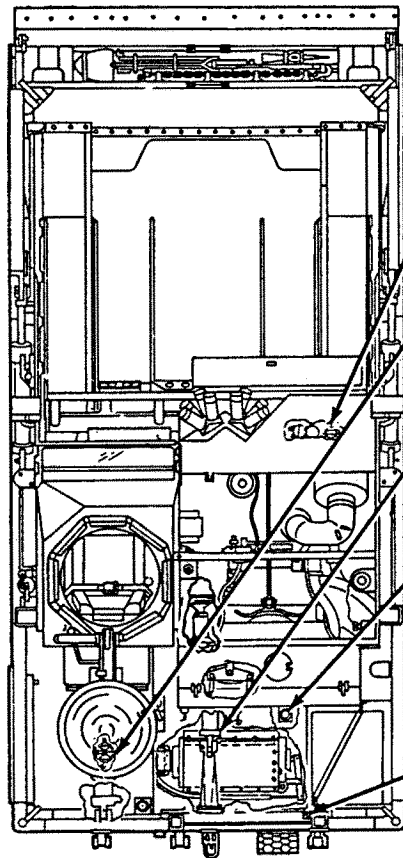

Q OE/HDO or OEA Engine Oil Filter (Refer to Unit Maintenance)

Q Fuel/Water Separator (Refer to Unit Maintenance)

Q GAA Ejector Cylinder End Cap (See Note 22) (C)

Q Final Drive Breather (Optional) (See Note 21) (O)

Q Winch Breather (See Note 23) (O)

QUARTERLY NOTES (CONTINUED)

Note 6

EJECTOR CYLINDER ROD END

WARNING

Do not operate ejector when personnel are in bowl.
Do not work in bowl unless ejector lock is engaged.
Failure to comply may result in severe injury to personnel.

- A Move ejector forward.
- B Lubricate fitting with GAA.
- C Retract ejector.

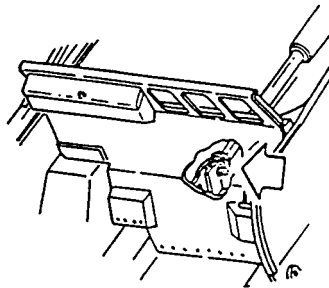

Note 7

APRON HINGE PINS AND CYLINDER RODS

Access through armor plate.
Lubricate six fittings with GAA.

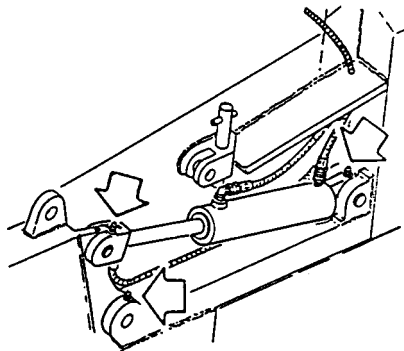

QUARTERLY NOTES (CONTINUED)

Note 8

EJECTOR GUIDE ROLLERS

WARNING

Do not operate ejector when personnel are in bowl.
Do not work in bowl unless ejector lock is engaged.
Failure to comply may result in severe injury to personnel.

- A Move ejector forward.
- B Lubricate ten fittings (one on each roller shaft) with GAA.
- C Retract ejector.

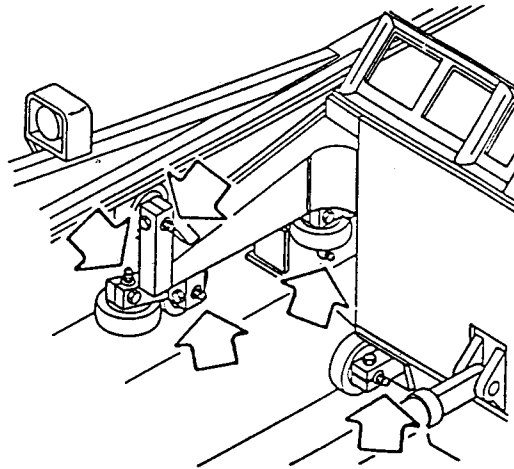

QUARTERLY NOTES (CONTINUED)

Note 9

SPEEDOMETER ADAPTER

Note

There are two speedometer adapter lube fitting configurations.

Access through rear floor plates.

Lubricate fitting with GAA.

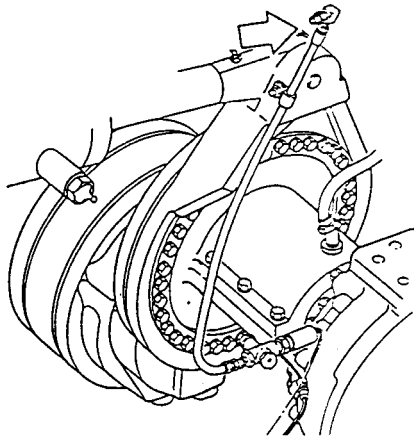

NEW CONFIGURATION

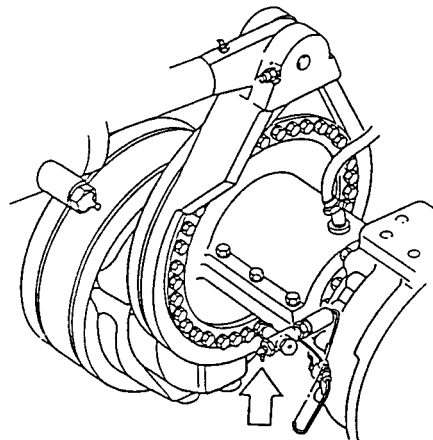

OLD CONFIGURATION

QUARTERLY NOTES (CONTINUED)

Note 10

TACHOMETER ADAPTER

Access through engine intake grilles.

Lubricate with GAA.

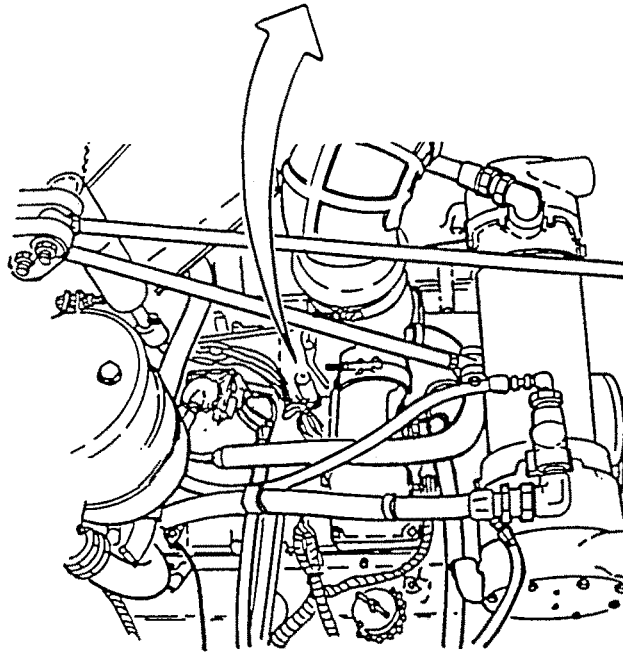
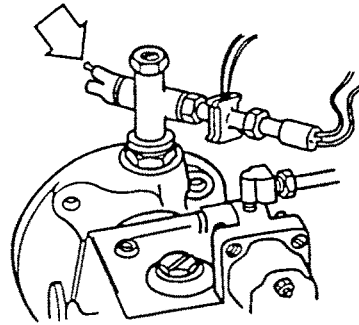

QUARTERLY NOTES (CONTINUED)

Note 11

WINCH CABLE AND DRUM

WARNING

Always wear leather gloves when handling wire rope. Never allow wire rope to run through hands. Broken or frayed wires may cause severe injury to personnel.

After use, clean cable and oil with OE/HDO or OEA.

- A Unwind and clean entire cable.
- B Brush-soak cable with oil (OE/HDO-30 or OEA).
- C Wipe off excess oil. Coat cable and drum with wire rope grease.
- D Rewind cable.

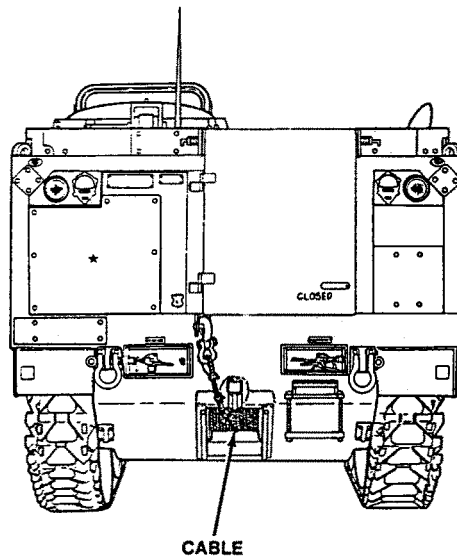

QUARTERLY NOTES (CONTINUED)

Note 12

TOWING PINTLE

Lubricate two fittings with GAA.

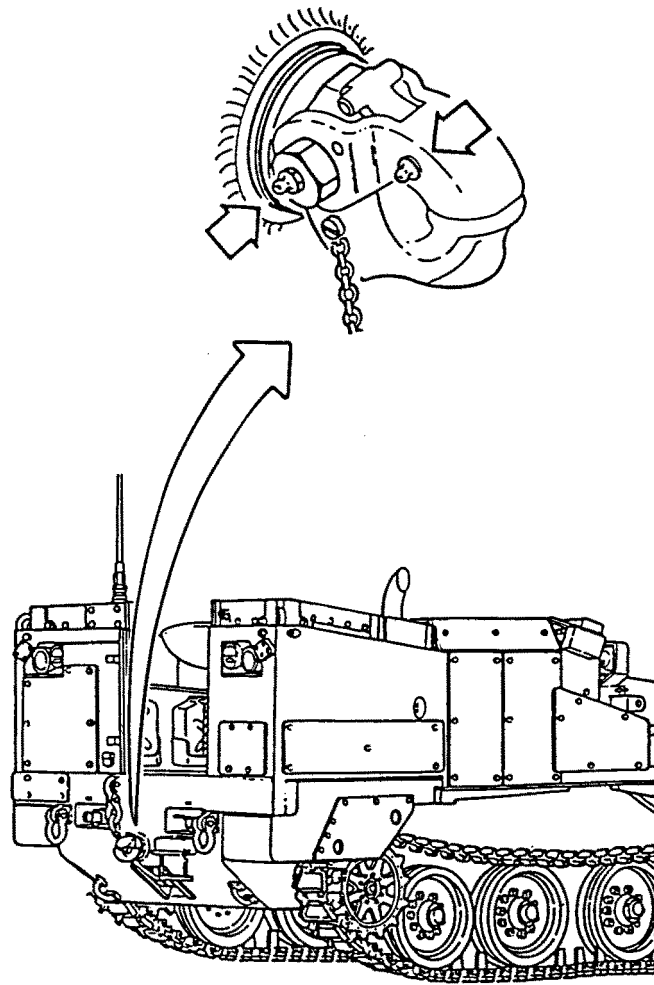

QUARTERLY NOTES (CONTINUED)

Note 13

TRANSFER CASE/STEER UNIT BREATHER

Access through intake grilles.

WARNING

Refer to p F-2 for drycleaning solvent (SD-3) precautions.

- A Remove breather (1) and clean with drycleaning solvent (SD-3).
- B Dry, inspect, and install breather (1).

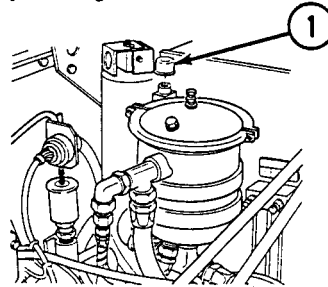

Note 14

HYDRAULIC TANK BREATHER

WARNING

Do not operate ejector when personnel are in bowl.
Do not work in bowl unless ejector lock is engaged.
Failure to comply may result in severe injury to personnel.

- A Move ejector forward.

WARNING

Refer to p F-2 for drycleaning solvent (SD-3) precautions.

- B Remove breather (1) from wall and clean with drycleaning solvent (SD-3).
- C Dry, inspect, and install breather (1) on wall.
- D Retract ejector.

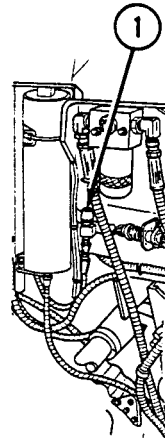

QUARTERLY NOTES (CONTINUED)

Note 15

PROP SHAFT

Note

There are two propeller shaft configurations. Perform step A for both and step B for old design.

Access through left rear hull access cover.

A Lubricate fitting (1) with GMD.

B Lubricate two fittings (2) with GMD.

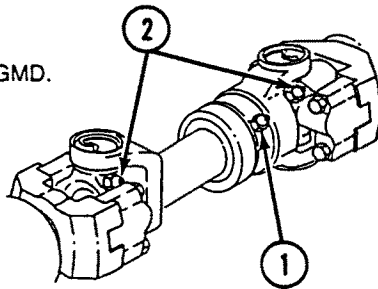

Note 16

HATCH CAM

A Close hatch cover (1).

B Lubricate two fittings (2) with GMD.

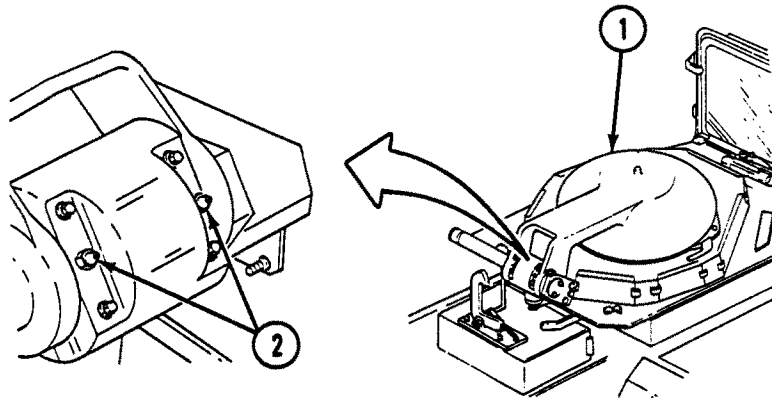

QUARTERLY NOTES (CONTINUED)

Note 17

HATCH CAM ROLLER

Note

There are two configurations of hatch cam rollers. For vehicles equipped with a cam roller lube fitting, perform the following steps.

- A Open hatch cover (1).
- B Lubricate fitting with GAA.

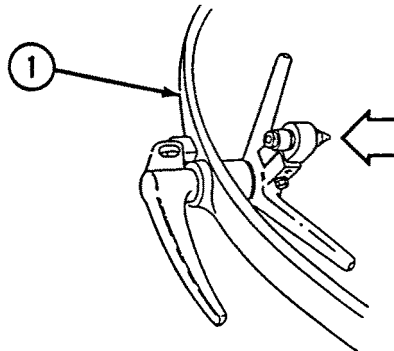

Note 18

TRACK ADJUSTING CYLINDER PINS

Access through rear floor plates.

Lubricate two fittings on left and right track adjusting cylinders with GAA.

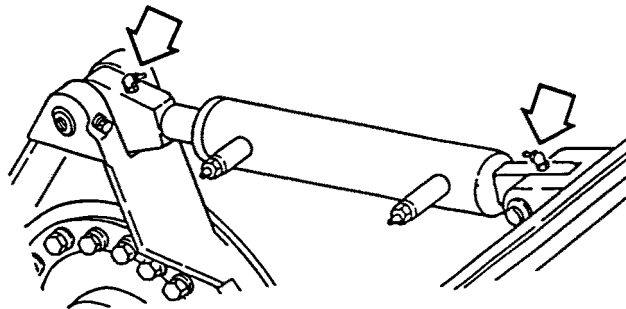

QUARTERLY NOTES (CONTINUED)

Note 19

DELETED

QUARTERLY NOTES (CONTINUED)

Note 20

WINCH LEVEL PLUG

Access through rear floor plates.

- A Unwind entire cable (p 2-72).
- B Rotate drum, ensuring fill and vent plugs (1) are pointing up.
- C Remove fill and vent plugs (1) and level plug (2) from winch (3).
- D Fill winch with GO-80/90 until oil appears at level plug hole (4).

WARNING

Refer to p F-2 for drycleaning solvent (SD-3) precautions.

- E Clean plugs (1) and (2) with drycleaning solvent (SD-3), dry thoroughly, and install on winch (3).
- F Rewind entire cable (p 2-72).

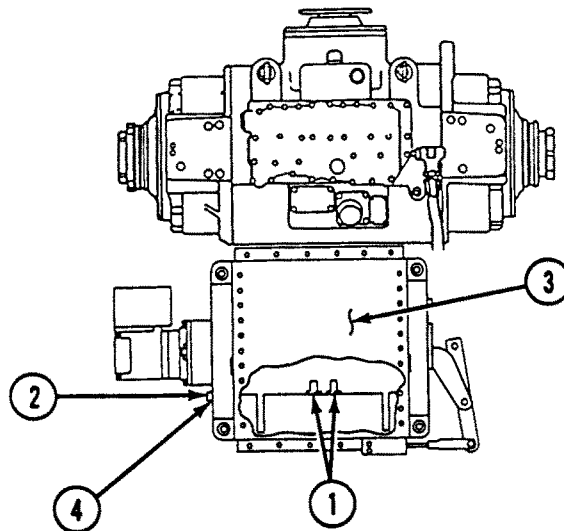

QUARTERLY NOTES (CONTINUED)

Note 21

FINAL DRIVE BREATHER

Note

Perform for vehicles equipped with final drive filler vent caps.

Access through rear floor plates.

WARNING

Refer to p F-2 for drycleaning solvent (SD-3) precautions.

- A Remove filler vent cap (1) and clean with drycleaning solvent (SD-3).
- B Install filler vent cap.

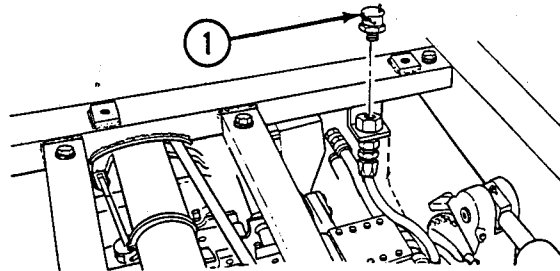

QUARTERLY NOTES (CONTINUED)

Note 22

EJECTOR CYLINDER END CAP

Access through rear floor plates.

Lubricate fitting with GAA.

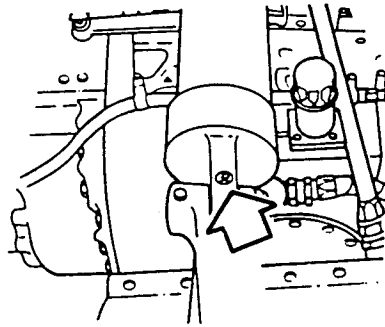

Note 23

WINCH BREATHER

WARNING

Refer to p F-2 for drycleaning solvent (SD-3) precautions.

- A Remove breather (1) and clean with drycleaning solvent (SD-3).
- B Dry, inspect, and install breather (1).

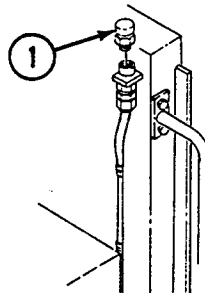

QUARTERLY NOTES (CONTINUED)

OIL CAN POINTS

Lubricate quarterly with PL-M or PL-S

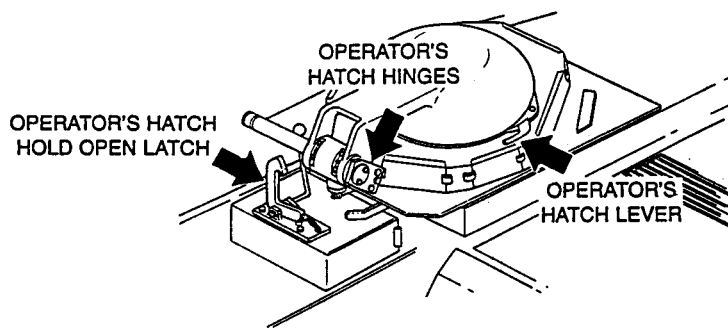
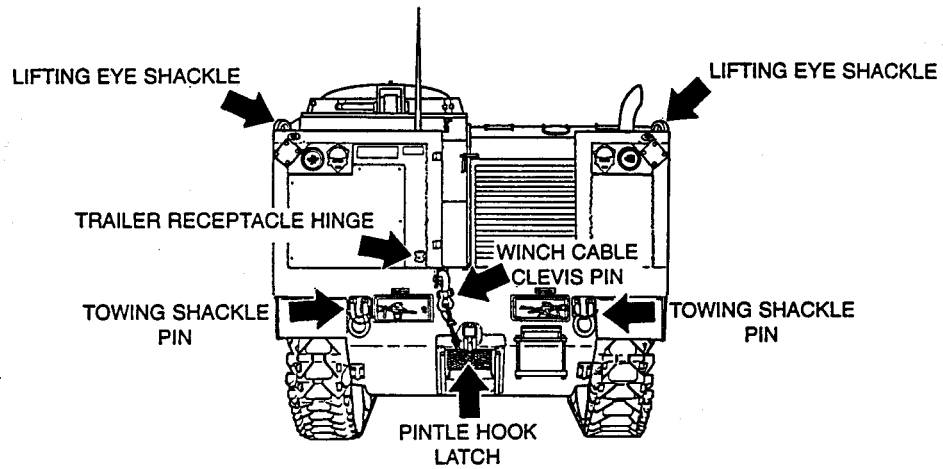

QUARTERLY NOTES (CONTINUED)

OIL CAN POINTS

Lubricate quarterly with PL-M or PL-S

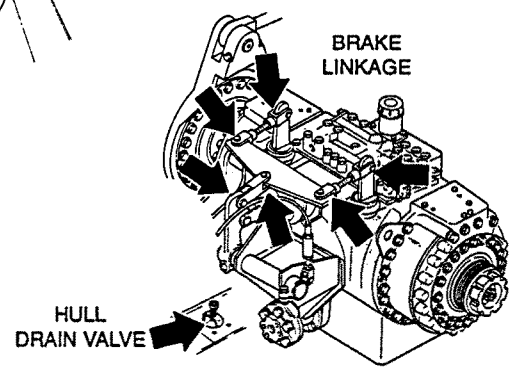
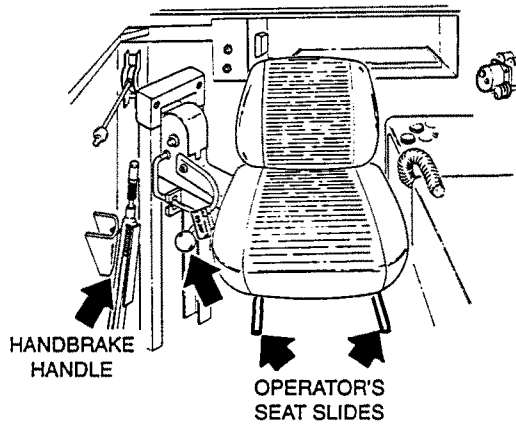
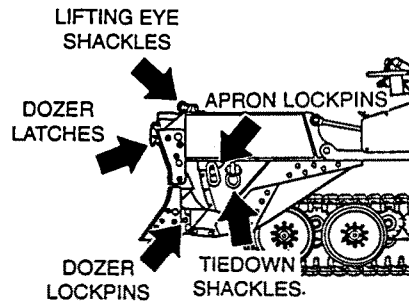
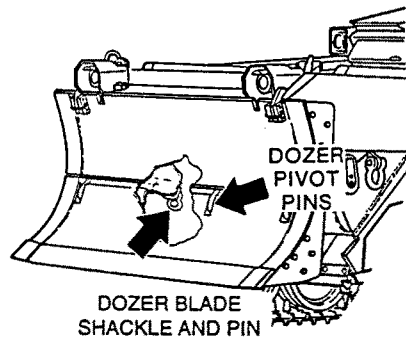

SEMIANNUAL NOTES

INTERVAL • LUBRICANT

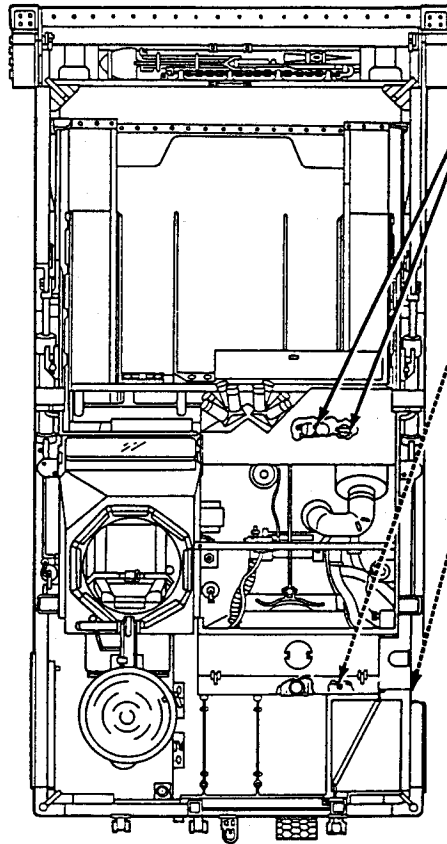

S OE/HDO or OEA Scavenger Pump and Transmission Oil Filters (Refer to (Unit Maintenance)

S GO Final Drive Fill (Refer to Unit Maintenance)

S Final Drive Drain (Refer to Unit Maintenance)

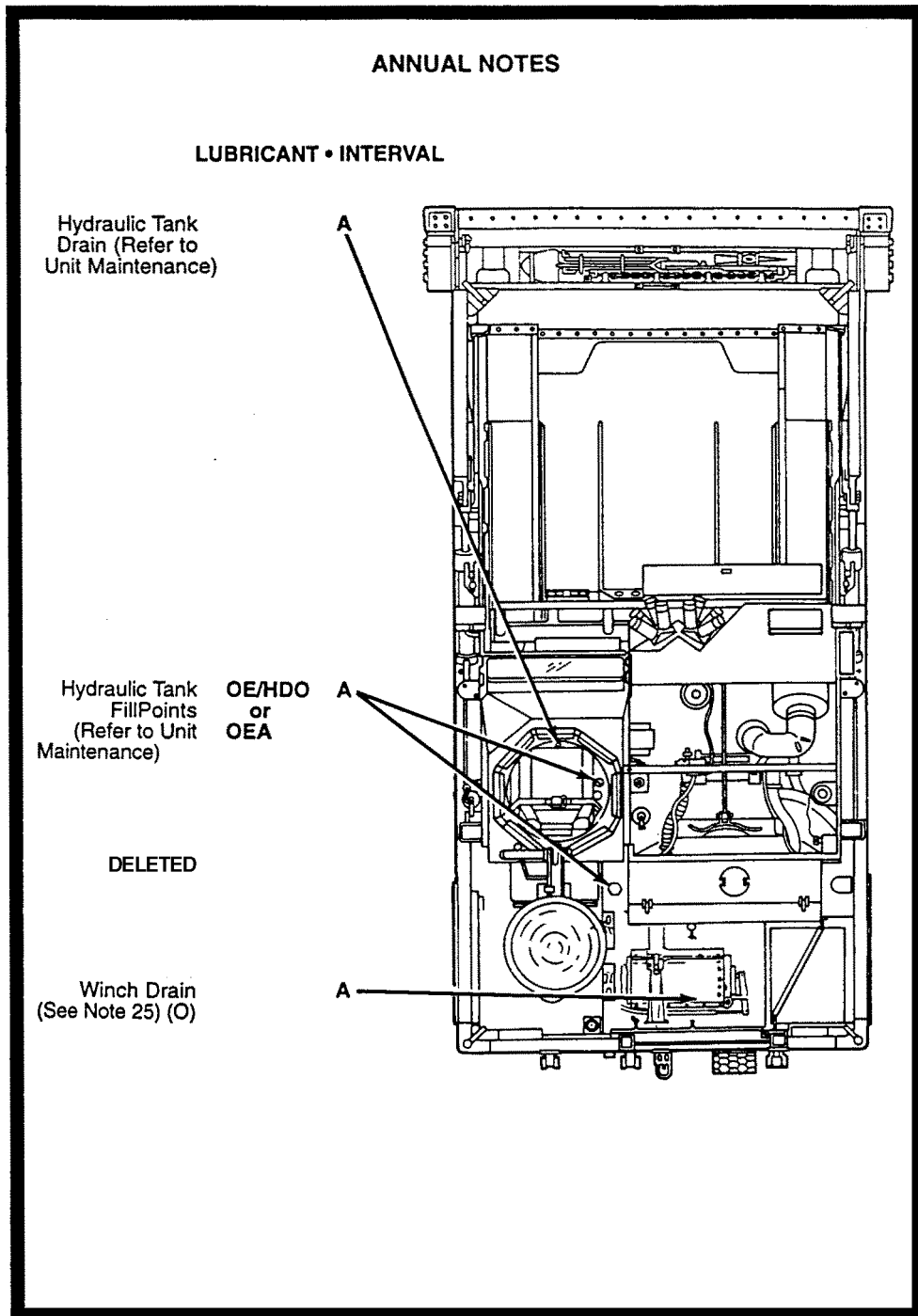

ANNUAL NOTES (CONTINUED)

INTERVAL • LUBRICANT

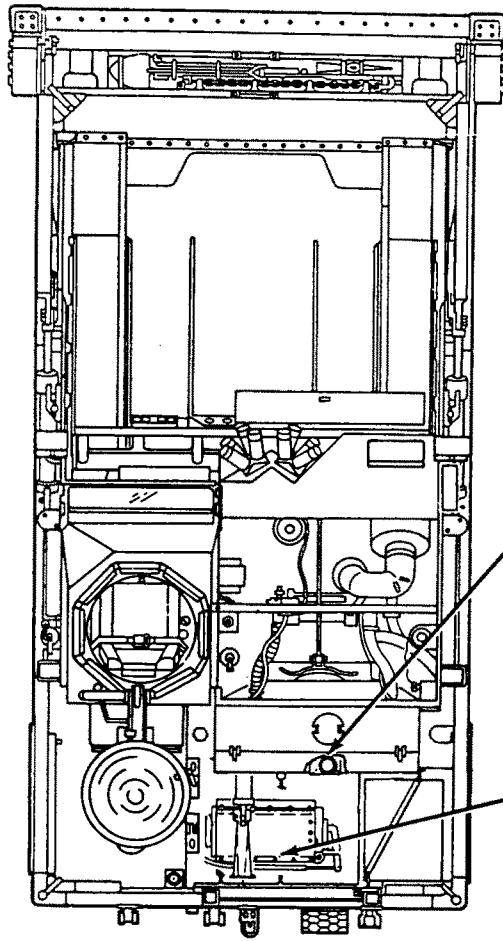

A OE/HDO Steer Unit
or or Filler Screen
OEA (See Note 26) (O)

DELETED

A GO-80/90 Winch Fill
(See Note 25) (O)



ANNUAL NOTES (CONTINUED)

Note 24

DELETED

ANNUAL NOTES (CONTINUED)

Note 25

WINCH DRAIN AND FILL

Access through floor plates.

- A Unwind entire cable (p 2-72).
- B Rotate drum, ensuring fill and vent plugs (1) are pointing down.
- C Remove level plug (2) and fill and vent plugs (1) from winch (3) and drain oil into suitable container.

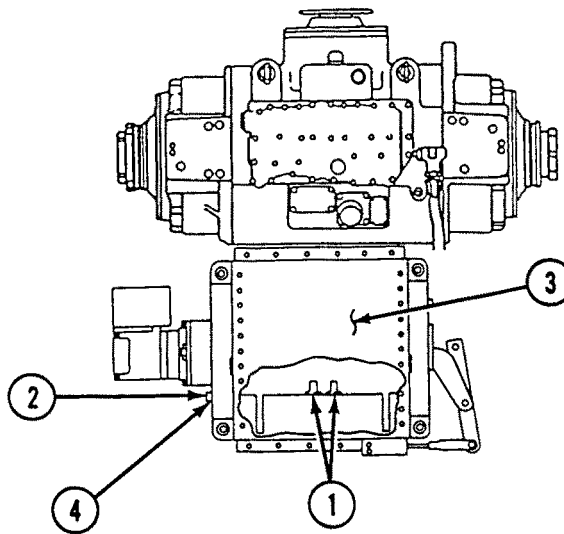

ANNUAL NOTES (CONTINUED)

WARNING

Refer to p F-1 for drycleaning solvent (SD-3) precautions.

- D Clean plugs (1) and plug (2) with drycleaning solvent (SD-3) and dry thoroughly.
- E Rotate drum, ensuring fill and vent plugs (1) are pointing up.
- F Fill winch with GO-80/90 until oil appears at level hole (4).
- G Install plugs (1) and (2) on winch (3) and rewind cable (p 2-72).

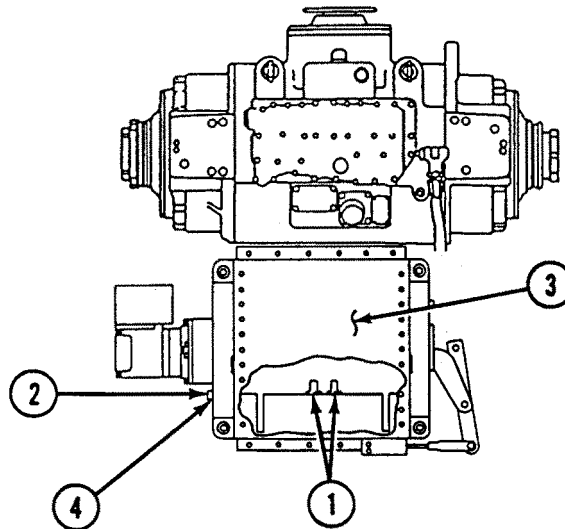

ANNUAL NOTES (CONTINUED)

Note 26

STEER UNIT FILLER SCREEN

Access through rear floor plates.

Remove steer unit filler neck.

WARNING

Refer to p F-2 for drycleaning solvent (SD-3) precautions.

- A Clean screen (1) with drycleaning solvent (SD-3).
- B Dry and inspect screen (1), and install filler neck.

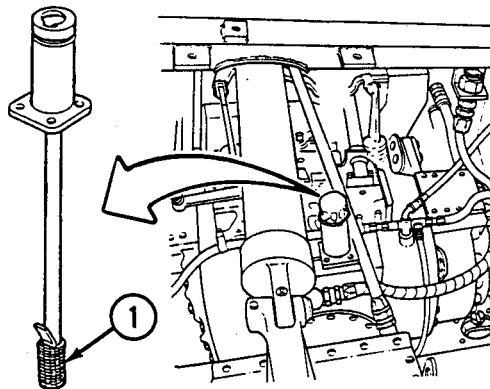

ON-CONDITION NOTES

LUBRICANT • INTERVAL

Transmission
Drain (Refer to
Unit Maintenance)

Steer Unit Drain
(Refer to Unit
Maintenance)

Transmission and
Steer Unit Fill
(Refer to Unit
Maintenance)

OE/HDO
or
OEA

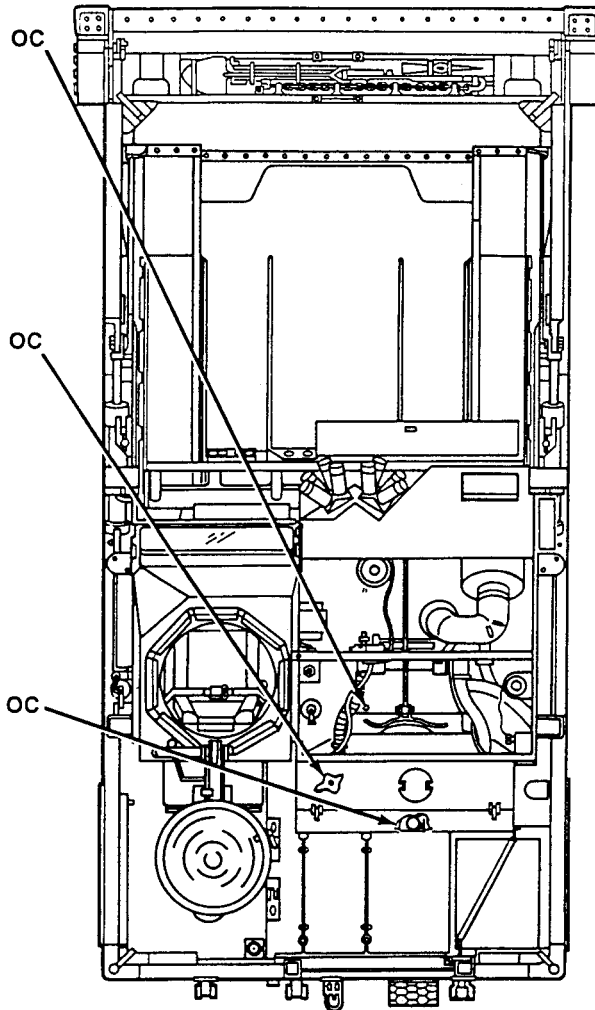

ON-CONDITION NOTES (CONTINUED)

INTERVAL • LUBRICANT

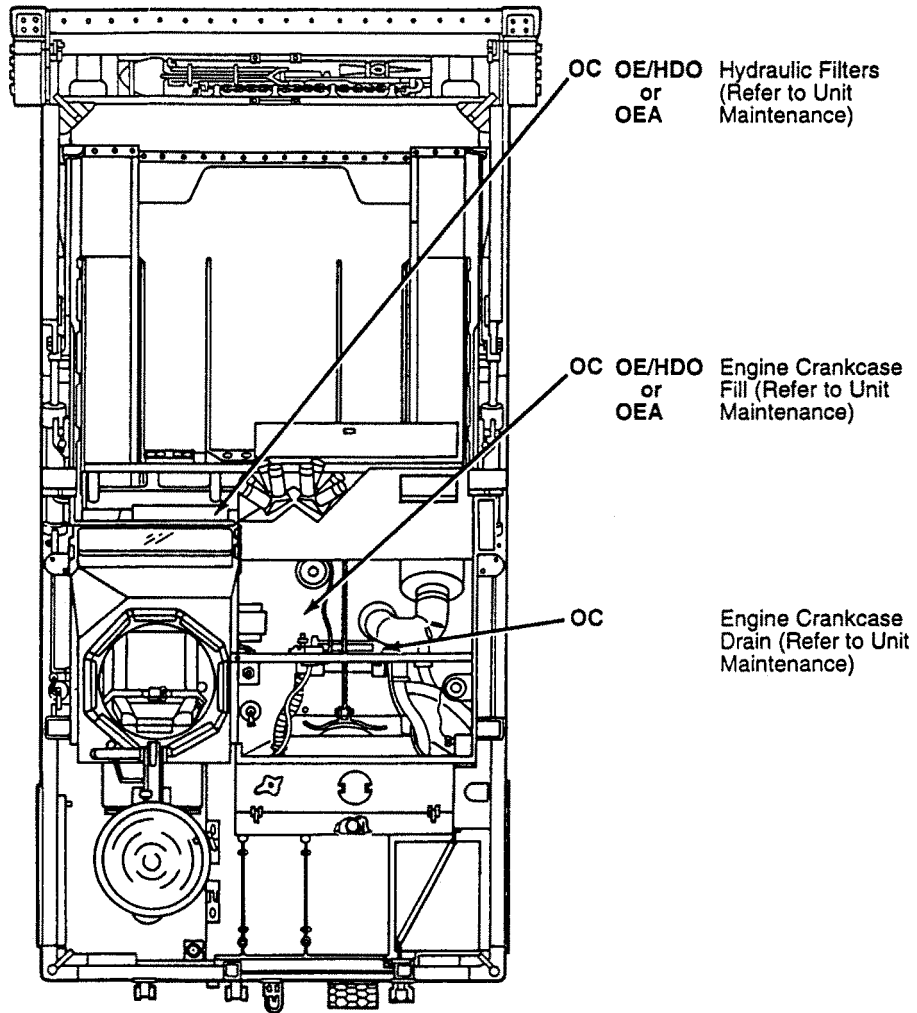

INDEX

Subject	Page	Subject	Page
A		C - Continued	
Adding coolant	3-24	Check, track tension	3-26
Additional authorization list:		Checkout procedures,	
Explanation of listing	C-1	instrument panel	2-39
General	C-1	Cleaning - bilge pump screen	3-22
Listing	C-2	Cold weather starting procedure	2-102
Scope	C-1	Communication system	2-81
Adjustment, parking brake lever	3-17	Components of End Item (COEI):	
Adjustment, track tension		Components of End Item List	B-3
(Old Production)	3-26	Explanation of columns	B-1
Adjustment, track tension		General	B-1
(New Production)	3-27.1	Scope	B-1
Air Cleaner - service engine	3-23	Controls and indicators, driver's	2-2
Air pressure relief	3-13	Coolant, adding	3-24
Antenna warnings	2-81	Cover operation, hatch	2-34
Armor plates - exterior	3-14	Cross-country driving	2-54
Assembly and preparation for use	2-32		
Auxiliary equipment, maintenance of	3-29	D	
Auxiliary equipment, operation of	2-78	Daily checks, initial adjustment and	2-32
Auxiliary source, starting		Data equipment	1-10
the engine using	2-77	Decals, operating instructions	2-94
		Description, equipment	1-3
B		Deflector, battery box top	3-16
Basic Issue Items (BII):		Dimmer switch	2-43, 2-44
Basic Issue Items List	B-5	Disconnect, final drive	2-116
Explanation of columns	B-1	Domelight	2-44
General	B-1	Dozer blade, folding the	2-56
Scope	B-1	Dozer blade, unfolding the	2-59
Batteries	3-18	Dozing, rough grading	2-71
Batteries:		Dozing, straight	2-68
Electrolyte level	3-18	Dozing, tilt	2-70
Loose connections	3-19	Driver's controls and indicators	2-2
Battery box	1-7	Driver's heater operation	2-80
Battery box top deflector	3-16	Driver's seat adjust	2-35
Battery generator indicator	2-41	Driving, cross-country	2-54
Bilge pump	1-9	Driving precautions	2-46
Bilge pump screen - cleaning	3-22	Driving the vehicle	2-46
Blade, folding the dozer	2-56	Dumping and spreading	2-67
Blade, unfolding the dozer	2-59	Dusty or sandy areas, operating in	2-97
Bowl, loading the	2-65		
Brake lever adjustment, parking	3-17	E	
		Ejector	1-4
C		Ejector control lever	2-3
Capabilities, characteristics, and features..	1-3	Emergency engine shutdown	2-122
Capacities	1-10	Emergency procedures	2-112
Care and handling, smoke grenades	2-93	Emergency stopping - loss of power	2-53
Cargo handling, palletized	2-52	Emergency stopping - loss of track	2-53
CB/GS steer selector lever	2-52		

INDEX

Subject	Page	Subject	Page
E - Continued		G - Continued	
Emptying the bowl after hydraulic failure	2-112	Goggles operation, night vision	2-87
Engine air cleaner - service	3-23	Grading, rough	2-71
Engine data	1-11	Grenade launcher operation, smoke	2-91
Engine exhaust grilles	3-16	Grilles, engine intake, and covers	3-21
Engine oil pressure indicator	2-39	Grilles, engine exhaust	3-16
Engine, prestarting the	2-35	H	
Engine intake grilles and covers	3-21	Hand fire extinguisher	2-78
Engine, starting the	2-37	Hand receipt manuals	1-2
Engine, stopping the	2-45,2-122	Hatch cover operation	2-34
Engine troubleshooting	3-2	Headlights	2-43
Equipment data	1-10	Heat stress guide	2-95
Equipment description	1-3	Heater operation, driver's	2-80
Exhaust grilles, engine	3-16	High altitude, operation at	2-100
Expendable supplies and materials list:		High beam indicator	2-40
Explanation of columns	D-1	Hydraulic failure, emptying the bowl after	2-112
Listing	D-2	Hydraulic oil temperature indicator	2-39
Scope	D-1	Hydraulic pressure filters	2-22, 2-24
Extreme heat, operation in	2-95	Hydraulic pressure, relief	3-13
F		I	
Fan, ventilation	2-45	Inclinometers	1-8, 2-5, 2-8.1
Features, capabilities and	1-3	Indicators:	
Filling cooling system	3-24	Battery generator	2-41
Filling - fuel tank	3-20	Engine oil	2-39
Filters, hydraulic pressure	2-22, 2-24	Fuel level	2-41
Final drives, disconnect	2-116	High beam	2-40
Fire extinguisher operation, fixed	2-79	Hydraulic oil temperature	2-39
Fire extinguisher operation, portable	2-78,3-25	Low air	2-40
Firing, smoke grenades	2-92	Low-oil pressure	2-40
Fixed fire extinguisher operation	2-79	Low trans pressure	2-40
Floodlights	2-6	Parking brake	2-41
Folding the dozer/ripper blade	2-56	Unsprung	2-41
Fording operation	2-104	Water temperature	2-39
Forms and records, maintenance	1-1	Information, general	1-1
Front of vehicle, raising	2-114	Initial adjustment and daily checks	2-32
Fuel level indicator	2-41	Instructions plates, operating instructions ...	2-94
Fuel tank - filling	3-20	Instructions, operating	2-1
Fuel/water separator	3-3, 3-4, 3-5, 3-7	Instrument panel checkout procedures	2-39
G		Intake grilles and covers, engine	3-21
Gage panel	2-8	IR illuminator	2-90
General data	1-10	L	
General information	1-1	Land performance	1-10
General lubrication requirements	F-1	Launcher, smoke grenade	2-91
Goggles, case	E-2	Leakage definitions	2-11

INDEX

Subject	Page	Subject	Page
L - Continued		O - Continued	
Lights:		Extreme cold	2-99
Headlights	2-43	Extreme heat	2-95
Panel lights	2-43	Gravel	2-101
Floodlights	2-6	Rainy or humid conditions	2-98
Domelight	2-44	Salt water areas	2-98
Dimmer switch	2-44	Operation on side slopes	2-100
Loading pallet	2-61	Operation of auxiliary equipment	2-78
Loading, smoke grenades	2-91	Operation of domelight	2-44
Loading the bowl	2-65	Operation of lights	2-43
Location and description of		Operation of ventilation fan	2-45
major components	1-4	Operation, recovery	2-118
Loss of power -		Operation under unusual conditions	2-95
emergency stopping	2-53	Operation under usual conditions	2-32
Loss of track -			
emergency stopping	2-53	P	
Low air indicator	2-40	Pad, track	3-28
Low engine oil level	3-8	Pallet, loading	2-61
Low-oil pressure indicator	2-40	Pallet, unloading	2-63
Low trans pressure indicator	2-40	Palletized cargo handling	2-61
Lubrication instructions	3-1	Panel, gage	2-8
		Panel lights	2-43
M		Panel, switch	2-6
Maintenance forms and records	1-1	Parking brake lever adjustment	3-17
Maintenance of auxiliary equipment	3-29	Parking brake indicator	2-41
Maintenance procedures	3-13	Performances, land	1-10
Maintenance, track assembly	3-26	Plates, armor, exterior	3-14
Major components,		Portable fire extinguisher	
location and description of	1-4	operation	2-78,3-25
Manuals, hand receipt	1-2	Precautions, driving	2-46
Mask, NBC	3-29	Preparation for use, assembly and	2-32
MCS unit	2-86.1	Pressure filters, hydraulic	2-22,2-24
Misfired smoke grenades	2-121	Pre-starting instructions	2-35
Mud, operation in	2-100	Preventive Maintenance Checks	
		and Services	2-9
N		Procedures, operating	2-32
NBC mask	3-29	Pump, bilge	1-9
NBC system	2-84	Purpose	1-3
Night vision goggles operation	2-87		
		R	
O		Radiator	1-8
Operating instructions	2-1	Radiator capacity	1-11
Operating instructions on decals and		Radio operation	2-81
instructions plates	2-94	Radius, turning	2-52
Operating procedures	2-32	Rainy or humid conditions,	
Operation at high altitude	2-100	operation in	2-98
Operation in:		Raising front of vehicle	2-114
Dusty or sandy areas	2-97		

INDEX

Subject	Page	Subject	Page
R - Continued		T - Continued	
Recovery operation	2-118	Track tension adjustment (Old Production)	3-26
Recovery, self	2-119	Track tension adjustment (New Production)	3-27.1
References	A-1	Track tension check	3-26
Relieving air pressure	3-13	Transmission, data	1-11
Relieving hydraulic pressure	3-13	Transmission oil indicator	2-39
Reporting equipment improvement recommendations	1-2	Transmission, shifting the	2-51
Rough grading	2-71	Troubleshooting	3-2
S		Turning radius	2-52
Salt water areas, operation in	2-98	U	
Scraper operation	2-65	Unfolding the dozer blade	2-59
Screen, bilge pump cleaning	3-22	Unit, MCS	2-86.1
Seat adjust, driver's	2-35	Unloading pallet	2-63
Self recovery	2-119	Unsprung indicator	2-41
Shifting the transmission	2-51	Unusual conditions, operation under	2-95
Side slopes, operation in	2-100	Usual conditions, operation under	2-32
Slave starting	2-77	V	
Smoke grenade launcher operation	2-91	Vehicle:	
Smoke grenades:		Driving	2-46
Care and handling	2-93	Raising front of	2-114
Fire	2-92	Starting	2-48
Loading	2-91	Steering	2-52
Removing misfired smoke grenades	2-121	Stopping	2-50
Snow, operation in	2-99	Towing	2-55
Spreading, dumping and	2-67	Ventilation fan, operation of	2-45
Starting in cold weather	2-102	Vent fan filter - service	2-30.6, 3-22.1
Starting the engine	2-37	W	
Starting the engine using auxiliary source	2-77	Warnings	a
Starting the vehicle	2-48	Water temperature Indicator	2-39
Steer unit data	1-11	Winch data	1-11
Steering the vehicle	2-52	Winch operation	2-72
Stopping the engine	2-45		
Stopping the vehicle	2-50		
Stowage and sign guide:			
Scope	E-1		
Stowage and sign guide	E-1		
Straight dozing	2-68		
Switch panel	2-6		
T			
Tilt dozing	2-70		
Towing the vehicle	2-55		
Track assembly maintenance	3-26		
Track pad	3-28		

By Order of the Secretary of the Army:

GORDON R. SULLIVAN
General, United States Army
Chief of Staff

Official:

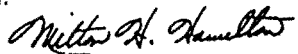

MILTON H. HAMILTON
*Administrative Assistant to the
Secretary of the Army*

02156

Distribution:

To be distributed in accordance with DA Form 12-37-E, Block 1271, Operator maintenance requirements for TM 5-2350-262-10.



THEN... JOT DOWN THE DOPE ABOUT IT ON THIS FORM. CAREFULLY TEAR IT OUT. FOLD IT AND DROP IT IN THE MAIL!

SOMETHING WRONG

WITH THIS PUBLICATION?

FROM: (PRINT YOUR UNIT'S COMPLETE ADDRESS)
 40TH COMBAT ENGINEERS BAT.
 FORT CAMPBELL, KY
 DATE SENT 21 JULY 1994

PUBLICATION NUMBER: TM 5-2350-262-10
 PUBLICATION DATE: DATE OF TM
 PUBLICATION TITLE: OPERATOR'S MANUAL, M9

BE EXACT. . . PIN-POINT WHERE IT IS

IN THIS SPACE TELL WHAT IS WRONG AND WHAT SHOULD BE DONE ABOUT IT:

PAGE NO.	PARA-GRAPH	FIGURE NO.	TABLE NO.
----------	------------	------------	-----------

2-36

3-5

TRANSMISSION SHIFT LEVER IN WRONG GEAR. PLACE GEAR IN NEUTRAL.
 TEMPERATURE READING IN STEP 3 IS 100°. READING SHOULD BE 150°.

SAMPLE

RECOMMEND CHANGES BE MADE.
 MARK-UP SHEET IS ATTACHED.

PRINTED NAME, GRADE OR TITLE, AND TELEPHONE NUMBERS
 JOHN R. HALL, SGT 523-6386

SIGN HERE:

DA FORM 2028-2
 1 JUL 79

PREVIOUS EDITIONS ARE OBSOLETE.

P.S.—IF YOUR UNIT WANTS TO KNOW ABOUT YOUR RECOMMENDATION MAKE A CARBON COPY OF THIS AND GIVE IT TO YOUR HEADQUARTERS.

SAMPLE

FILL IN YOUR
UNIT'S ADDRESS



FOLD BACK

DEPARTMENT OF THE ARMY

TEAR ALONG PERFORATED LINE

**Commander
U.S. Army Tank-automotive and Armaments Command
ATTN: AMSTA-AC-NML
Rock Island , IL 61299-7630**



SOMETHING WRONG

WITH THIS PUBLICATION?

THEN... JOT DOWN THE DOPE ABOUT IT ON THIS FORM. CAREFULLY TEAR IT OUT. FOLD IT AND DROP IT IN THE MAIL!

FROM: (PRINT YOUR UNIT'S COMPLETE ADDRESS)

DATE SENT

PUBLICATION NUMBER TM 5-2350-262-10	PUBLICATION DATE	PUBLICATION TITLE OPERATOR'S MANUAL, M9
---	------------------	---

BE EXACT. . . PIN-POINT WHERE IT IS				IN THIS SPACE TELL WHAT IS WRONG AND WHAT SHOULD BE DONE ABOUT IT:
PAGE NO.	PARA-GRAPH	FIGURE NO.	TABLE NO.	

PRINTED NAME, GRADE OR TITLE, AND TELEPHONE NUMBERS	SIGN HERE:
---	------------

DA FORM 2028-2
1 JUL 79

PREVIOUS EDITIONS ARE OBSOLETE.

P.S.—IF YOUR OUTFIT WANTS TO KNOW ABOUT YOUR RECOMMENDATION MAKE A CARBON COPY OF THIS AND GIVE IT TO YOUR HEADQUARTERS.

FILL IN YOUR
UNITS ADDRESS



DEPARTMENT OF THE ARMY

Place
Stamp
Here

DIRECTOR
ARMAMENT AND CHEMICAL ACQUISITION
AND LOGISTICS ACTIVITY
ATTN: AMSTA-AC-NMLI
ROCK ISLAND IL 61201-9948

TEAR ALONG PERFORATED LINE

		SOMETHING WRONG		WITH THIS PUBLICATION?
		THEN . . . JOT DOWN THE DOPE ABOUT IT ON THIS FORM. CAREFULLY TEAR IT OUT. FOLD IT AND DROP IT IN THE MAIL!		FROM: (PRINT YOUR UNIT'S COMPLETE ADDRESS)
				DATE SENT
PUBLICATION NUMBER		PUBLICATION DATE		PUBLICATION TITLE
TM 5-2350-262-10				OPERATOR'S MANUAL, M9
BE EXACT. . . PIN-POINT WHERE IT IS				IN THIS SPACE TELL WHAT IS WRONG AND WHAT SHOULD BE DONE ABOUT IT:
PAGE NO.	PARA-GRAPH	FIGURE NO.	TABLE NO.	
PRINTED NAME, GRADE OR TITLE, AND TELEPHONE NUMBERS				SIGN HERE:

DA FORM 1 JUL 79 **2028-2**

PREVIOUS EDITIONS ARE OBSOLETE.

P.S.—IF YOUR OUTFIT WANTS TO KNOW ABOUT YOUR RECOMMENDATION MAKE A CARBON COPY OF THIS AND GIVE IT TO YOUR HEADQUARTERS.

FILL IN YOUR
UNIT'S ADDRESS



DEPARTMENT OF THE ARMY

Place
Stamp
Here

DIRECTOR
ARMAMENT AND CHEMICAL ACQUISITION
AND LOGISTICS ACTIVITY
ATTN: AMSTA-AC-NMLI
ROCK ISLAND IL 61201-9948

TEAR ALONG PERFORATED LINE

		SOMETHING WRONG		WITH THIS PUBLICATION?
		THEN . . . JOT DOWN THE DOPE ABOUT IT ON THIS FORM. CAREFULLY TEAR IT OUT. FOLD IT AND DROP IT IN THE MAIL!		FROM: (PRINT YOUR UNIT'S COMPLETE ADDRESS)
				DATE SENT
PUBLICATION NUMBER		PUBLICATION DATE		PUBLICATION TITLE
TM 5-2350-262-10				OPERATOR'S MANUAL, M9
BE EXACT. . . PIN-POINT WHERE IT IS				IN THIS SPACE TELL WHAT IS WRONG AND WHAT SHOULD BE DONE ABOUT IT:
PAGE NO.	PARA-GRAPH	FIGURE NO.	TABLE NO.	
PRINTED NAME, GRADE OR TITLE, AND TELEPHONE NUMBERS				SIGN HERE:

DA ^{FORM} **2028-2**
1 JUL 79

PREVIOUS EDITIONS ARE OBSOLETE.

P.S.—IF YOUR OUTFIT WANTS TO KNOW ABOUT YOUR RECOMMENDATION MAKE A CARBON COPY OF THIS AND GIVE IT TO YOUR HEADQUARTERS.

FILL IN YOUR
UNIT'S ADDRESS



DEPARTMENT OF THE ARMY

Place
Stamp
Here

TEAR ALONG PERFORATED LINE

**DIRECTOR
ARMAMENT AND CHEMICAL ACQUISITION
AND LOGISTICS ACTIVITY
ATTN: AMSTA-AC-NMLI
ROCK ISLAND IL 61201-9948**

THE METRIC SYSTEM AND EQUIVALENTS

LINEAR MEASURE

1 Centimeter = 10 Millimeters = 0.01 Meters = 0.3937 Inches
 1 Meter = 100 Centimeters = 1,000 Millimeters = 39.37 Inches
 1 Kilometer = 1,000 Meters = 0.621 Miles

WEIGHTS

1 Gram = 0.001 Kilograms = 1,000 Milligrams = 0.035 Ounces
 1 Kilogram = 1,000 Grams = 2.2 Lb
 1 Metric Ton = 1,000 Kilograms = 1 Megagram = 1.1 Short Tons

LIQUID MEASURE

1 Milliliter = 0.001 Liters = 0.0338 Fluid Ounces
 1 Liter = 1,000 Milliliters = 33.82 Fluid Ounces

SQUARE MEASURE

1 Sq Centimeter = 100 Sq Millimeters = 0.155 Sq Inches
 1 Sq Meter = 10,000 Sq Centimeters = 10.76 Sq Feet
 1 Sq Kilometer = 1,000,000 Sq Meters = 0.386 Sq Miles

CUBIC MEASURE

1 Cu Centimeter = 1,000 Cu Millimeters = 0.06 Cu Inches
 1 Cu Meter = 1,000,000 Cu Centimeters = 35.31 Cu Feet

TEMPERATURE

$5/9 (^{\circ}\text{F} - 32) = ^{\circ}\text{C}$
 212° Fahrenheit is equivalent to 100° Celsius
 90° Fahrenheit is equivalent to 32.2° Celsius
 32° Fahrenheit is equivalent to 0° Celsius
 $9/5 ^{\circ}\text{C} + 32 = ^{\circ}\text{F}$

APPROXIMATE CONVERSION FACTORS

TO CHANGE	TO	MULTIPLY BY
Inches	Centimeters	2.540
Feet	Meters	0.305
Yards	Meters	0.914
Miles	Kilometers	1.609
Square Inches	Square Centimeters	6.451
Square Feet	Square Meters	0.093
Square Yards	Square Meters	0.836
Square Miles	Square Kilometers	2.590
Acres	Square Hectometers	0.405
Cubic Feet	Cubic Meters	0.028
Cubic Yards	Cubic Meters	0.765
Fluid Ounces	Milliliters	29.573
Pints	Liters	0.473
Quarts	Liters	0.946
Gallons	Liters	3.785
Ounces	Grams	28.349
Pounds	Kilograms	0.454
Short Tons	Metric Tons	0.907
Pound-Feet	Newton-Meters	1.356
Pounds Per Square Inch	Kilopascals	6.895
Miles Per Gallon	Kilometers Per Liter	0.425
Miles Per Hour	Kilometers Per Hour	1.609
TO CHANGE	TO	MULTIPLY BY
Centimeters	Inches	0.394
Meters	Feet	3.280
Meters	Yards	1.094
Kilometers	Miles	0.621
Square Centimeters	Square Inches	0.155
Square Meters	Square Feet	10.764
Square Meters	Square Yards	1.196
Square Kilometers	Square Miles	0.386
Square Hectometers	Acres	2.471
Cubic Meters	Cubic Feet	35.315
Cubic Meters	Cubic Yards	1.308
Milliliters	Fluid Ounces	0.034
Liters	Pints	2.113
Liters	Quarts	1.057
Liters	Gallons	0.264
Grams	Ounces	0.035
Kilograms	Pounds	2.205
Metric Tons	Short Tons	1.102
Newton-Meters	Pound-Feet	0.738
Kilopascals	Pounds Per Square Inch	0.145
Kilometers Per Liter	Miles Per Gallon	2.354
Kilometers Per Hour	Miles Per Hour	0.621

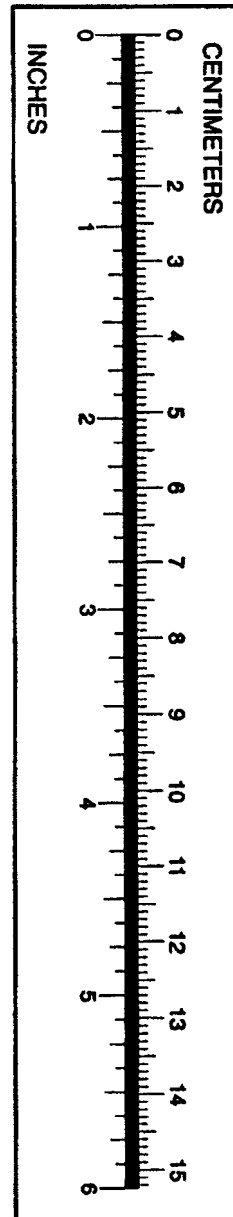

PIN: 060710-005